

Service

Residential/Commercial Generator Sets



Models:

8RESV/RESVL
10RESV/RESVL
12RESV/RESVL

Controllers:
RDC2 Controller
DC2 Controller

KOHLER®

TP-6881 8/24c

Table of Contents

Safety Precautions and Instructions	5
Introduction	9
List of Related Materials	9
Service Assistance	10
Section 1 Specifications	11
1.1 Introduction	11
1.2 Controller Specifications	11
1.3 Engine Service	11
1.4 Engine Specifications	11
1.5 Alternator Specifications	12
1.6 Torque Specifications	12
1.7 Service View	13
Section 2 Scheduled Maintenance	15
2.1 Service Schedule	16
2.1.1 Service Schedule	17
2.2 Lubrication System	18
2.2.1 Low Oil Pressure Shutdown	18
2.2.2 Oil Check	18
2.2.3 Engine Oil Recommendation	18
2.2.4 Oil Change Procedure	18
2.2.5 Resetting the Maintenance Timer	20
2.3 Spark Plugs	20
2.4 Air Cleaner Service	21
2.4.1 Air Cleaner, 8RESV/RESVL Models	21
2.4.2 Air Cleaner, 10/12RESV/RESVL Models	22
2.5 Cooling System	23
2.6 Exhaust System	23
2.7 Stepper Motor Coupling	24
2.8 Fuel System Maintenance	24
2.9 Battery	25
2.9.1 Checking Electrolyte Level	26
2.9.2 Checking Specific Gravity	26
2.10 Storage Procedure	27
2.10.1 Lubricating System	27
2.10.2 Fuel System	27
2.10.3 Cylinder Lubrication	27
2.10.4 Exterior Preparation	27
2.10.5 Battery	27
Section 3 Controller	29
3.1 Introduction	29
3.2 SiteTech and OnCue Plus Software	29
3.3 Controller Parameters	30
3.3.1 Controller Parameters Table	30
3.3.2 Notes on Selected Parameters	30
3.4 Controller Firmware	44
3.5 Controller Replacement	45
3.5.1 Controller Replacement Procedure	45
3.6 Controller Setup	47
3.7 Voltage Calibration	50
3.7.1 Calibration using the RDC2 Controller Keypad and Menus	50
3.7.2 Calibration Using SiteTech	52
3.8 Setting the OnCue Plus Password	53
3.8.1 RDC2 Controller	53
3.8.2 DC2 Controller	53
Section 4 Troubleshooting	55
4.1 Introduction	55
4.2 Theory of Operation, Electronic Start Sequence	55

Table of Contents, continued

4.3	Initial Checks	56
4.4	USB Port	56
4.5	Circuit Protection	56
4.6	Thermostat Information	57
4.7	OnCue Plus Troubleshooting	57
4.8	Fuel System Troubleshooting	57
4.9	Fault Messages	58
4.10	Status Messages	63
4.11	Troubleshooting Chart	66
4.12	Controller Troubleshooting	73
Section 5 Component Testing and Adjustment		75
5.1	Introduction	75
5.2	Theory of Operation	75
5.3	Alternator Excitation	76
5.3.1	No to Low Voltage Operation	76
5.3.2	Erratic Voltage Regulation	77
5.3.3	Separate Excitation	77
5.4	Stator	78
5.5	Main Field (Rotor)	80
5.6	Slip Rings	82
5.7	Brushes	82
5.8	Voltage Connections	83
5.9	Voltage Adjustments	83
5.9.1	Voltage Regulator Average Voltage Adjustment	84
5.9.2	Volts/Hz Slope and Cut-In Frequency	85
5.9.3	Voltage Regulator Gain	85
5.10	Governor System	86
5.10.1	Operation	86
5.10.2	Initial Checks	86
5.10.3	Hunting/Surging	87
5.10.4	Governor System Operation Test	88
5.11	Frequency Adjustment	90
5.11.1	Engine Speed Gain Adjustment for the Governor	91
5.11.2	Engine Speed Adjustment for Governor	91
5.11.3	Advanced Speed Control	91
5.12	Fault Shutdown Tests	93
5.12.1	Controller Fault Shutdown Functions	93
5.12.2	Fault Shutdown Switches	95
5.13	Fuel Systems	97
5.13.1	Fuel Solenoid Valve	98
5.13.2	Capacitive Discharge Ignition (CDI) Timing	98
5.13.3	Fuel Regulators	99
5.14	Fuel Conversion	99
5.14.1	Fuel Selector Valve Adjustment Screw	102
5.15	Starter and Run Relay	102
5.16	Continuity Checks	103
Section 6 Disassembly/Reassembly		105
6.1	Initial Steps	106
6.2	Disassembly	107
6.3	Reassembly	113
Section 7 Drawings and Diagrams		121
Appendix A Abbreviations		131
Appendix B Common Hardware Application Guidelines		133
Appendix C General Torque Specifications		134
Appendix D Common Hardware Identification		136
Appendix E Common Hardware List		137

Safety Precautions and Instructions

IMPORTANT SAFETY INSTRUCTIONS. Electromechanical equipment, including generator sets, transfer switches, switchgear, and accessories, can cause bodily harm and pose life-threatening danger when improperly installed, operated, or maintained. To prevent accidents be aware of potential dangers and act safely. Read and follow all safety precautions and instructions. **SAVE THESE INSTRUCTIONS.**

This manual has several types of safety precautions and instructions: Danger, Warning, Caution, and Notice.

DANGER

Danger indicates the presence of a hazard that **will cause severe personal injury, death, or substantial property damage.**

WARNING

Warning indicates the presence of a hazard that **can cause severe personal injury, death, or substantial property damage.**

CAUTION

Caution indicates the presence of a hazard that **will or can cause minor personal injury or property damage.**

NOTICE

Notice communicates installation, operation, or maintenance information that is safety related but not hazard related.



Safety decals affixed to the equipment in prominent places alert the operator or service technician to potential hazards and explain how to act safely. The decals are shown throughout this publication to improve operator recognition. Replace missing or damaged decals.

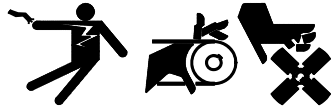

Accidental Starting

 WARNING

Accidental starting. Can cause severe injury or death.
Disconnect the battery cables before working on the generator set. Remove the negative (-) lead first when disconnecting the battery. Reconnect the negative (-) lead last when reconnecting the battery.

Disabling the generator set. Accidental starting can cause severe injury or death. Before working on the generator set or equipment connected to the set, disable the generator set as follows: (1) Press the generator set off/reset button to shut down the generator set. (2) Disconnect the power to the battery charger, if equipped. (3) Remove the battery cables, negative (-) lead first. Reconnect the negative (-) lead last when reconnecting the battery. Follow these precautions to prevent the starting of the generator set by the remote start/stop switch.

Battery

 WARNING

Sulfuric acid in batteries. Can cause severe injury or death.
Wear protective goggles and clothing. Battery acid may cause blindness and burn skin.

 WARNING

Explosion. Can cause severe injury or death. Relays in the battery charger cause arcs or sparks.
Locate the battery in a well-ventilated area. Isolate the battery charger from explosive fumes.

Battery electrolyte is a diluted sulfuric acid. Battery acid can cause severe injury or death. Battery acid can cause blindness and burn skin. Always wear splashproof safety goggles, rubber gloves, and boots when servicing the battery. Do not open a sealed battery or mutilate the battery case. If battery acid splashes in the eyes or on the skin, immediately flush the affected area for 15 minutes with large quantities of clean water. Seek immediate medical aid in the case of eye contact. Never add acid to a battery after placing the battery in service, as this may result in hazardous spattering of battery acid.

Battery acid cleanup. Battery acid can cause severe injury or death. Battery acid is electrically conductive and corrosive. Add 500 g (1 lb.) of bicarbonate of soda (baking soda) to a container with 4 L (1 gal.) of water and mix the neutralizing solution. Pour the neutralizing solution on the spilled battery acid and continue to add the neutralizing solution to the spilled battery acid until all evidence of a chemical reaction (foaming) has ceased. Flush the resulting liquid with water and dry the area.

Battery gases. Explosion can cause severe injury or death. Battery gases can cause an explosion. Do not smoke or permit flames or sparks to occur near a battery at any time, particularly when it is charging. Do not dispose of a battery in a fire. To prevent burns and sparks that could cause an explosion, avoid touching the battery terminals with tools or other metal objects.

Remove all jewelry before servicing the equipment. Discharge static electricity from your body before touching batteries by first touching a grounded metal surface away from the battery. To avoid sparks, do not disturb the battery charger connections while the battery is charging. Always turn the battery charger off before disconnecting the battery connections. Ventilate the compartments containing batteries to prevent accumulation of explosive gases.

Battery short circuits. Explosion can cause severe injury or death.

Short circuits can cause bodily injury and/or equipment damage. Disconnect the battery before generator set installation or maintenance. Remove all jewelry before servicing the equipment. Use tools with insulated handles. Remove the negative (-) lead first when disconnecting the battery. Reconnect the negative (-) lead last when reconnecting the battery. Never connect the negative (-) battery cable to the positive (+) connection terminal of the starter solenoid. Do not test the battery condition by shorting the terminals together.

Engine Backfire/Flash Fire

⚠ WARNING

<p>Risk of fire. Can cause severe injury or death.</p> <p>Do not smoke or permit flames or sparks near fuels or the fuel system.</p>

Servicing the fuel system. A flash fire can cause severe injury or death.

Do not smoke or permit flames or sparks near the carburetor, fuel line, fuel filter, fuel pump, or other potential sources of spilled fuels or fuel vapors. Catch fuels in an approved container when removing the fuel line or carburetor.

Servicing the air cleaner. A sudden backfire can cause severe injury or death. Do not operate the generator set with the air cleaner removed.

Combustible materials. A fire can cause severe injury or death. Generator set engine fuels and fuel vapors are flammable and explosive. Handle these materials carefully to minimize the risk of fire or explosion. Equip the compartment or nearby area with a fully charged fire extinguisher. Select a fire extinguisher rated ABC or BC for electrical fires or as recommended by the local fire code or an authorized agency. Train all personnel on fire extinguisher operation and fire prevention procedures.

Exhaust System

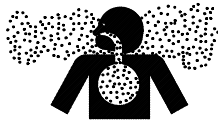
⚠ WARNING

<p>Carbon monoxide. Can cause severe nausea, fainting, or death.</p> <p>The exhaust system must be leakproof and routinely inspected.</p>

Generator set operation. Carbon monoxide can cause severe nausea, fainting, or death. Carbon monoxide is an odorless, colorless, tasteless, nonirritating gas that can cause death if inhaled for even a short time. Avoid breathing exhaust fumes when working on or near the generator set. Never operate the generator set inside a building unless the exhaust gas is piped safely outside. Never operate the generator set where exhaust gas could accumulate and seep back inside a potentially occupied building.

Carbon monoxide detectors. Carbon monoxide can cause severe nausea, fainting, or death. Install carbon monoxide detectors on each level of any building adjacent to the generator set. Locate the detectors to adequately warn the building's occupants of the presence of carbon monoxide. Keep the detectors operational at all times. Periodically test and replace the carbon monoxide detectors according to the manufacturer's instructions.

Carbon monoxide symptoms. Carbon monoxide can cause severe nausea, fainting, or death. Carbon monoxide is a poisonous gas present in exhaust gases. Carbon monoxide is an odorless, colorless, tasteless, nonirritating gas that can cause death if inhaled for even a short time. Carbon monoxide poisoning symptoms include but are not limited to the following:

- Light-headedness, dizziness
- Physical fatigue, weakness in joints and muscles
- Sleepiness, mental fatigue, inability to concentrate or speak clearly, blurred vision
- Stomachache, vomiting, nausea

If experiencing any of these symptoms and carbon monoxide poisoning is possible, seek fresh air immediately and remain active. Do not sit, lie down, or fall asleep. Alert others to the possibility of carbon monoxide poisoning. Seek medical attention if the condition of affected persons does not improve within minutes of breathing fresh air.

Fuel System

⚠ WARNING

<p>Explosive fuel vapors. Can cause severe injury or death.</p> <p>Use extreme care when handling, storing, and using fuels.</p>

The fuel system. Explosive fuel vapors can cause severe injury or death. Vaporized fuels are highly explosive. Use extreme care when handling and storing fuels. Store fuels in a well-ventilated area away from spark-producing equipment and out of the reach of children. Never add fuel to the tank while the engine is running because spilled fuel may ignite on contact with hot parts or from sparks. Do not smoke or permit flames or sparks to occur near sources of spilled fuel or fuel vapors. Keep the fuel lines and connections tight and in good condition. Do not replace flexible fuel lines with rigid lines. Use flexible sections to avoid fuel line breakage caused by vibration. Do not operate the generator set in the presence of fuel leaks, fuel accumulation, or sparks. Repair fuel systems before resuming generator set operation.

Gas fuel leaks. Explosive fuel vapors can cause severe injury or death. Fuel leakage can cause an explosion. Check the LPG vapor or natural gas fuel system for leakage by using a soap and water solution with the fuel system test pressurized to 6–8 ounces per square inch (10–14 inches water column). Do not use a soap solution containing either ammonia or chlorine because both prevent bubble formation. A successful test depends on the ability of the solution to bubble.

LPG liquid withdrawal fuel leaks. Explosive fuel vapors can cause severe injury or death. Fuel leakage can cause an explosion. Check the LPG liquid withdrawal fuel system for leakage by using a soap and water solution with the fuel system test pressurized to at least 90 psi (621 kPa). Do not use a soap solution containing either ammonia or chlorine because both prevent bubble formation. A successful test depends on the ability of the solution to bubble.

Hazardous Noise

⚠ CAUTION

<p>Hazardous noise. Can cause hearing loss.</p> <p>Never operate the generator set without a muffler or with a faulty exhaust system.</p>

Hazardous Voltage/ Moving Parts

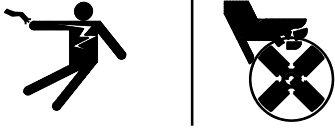
⚠ DANGER

<p>Hazardous voltage. Will cause severe injury or death.</p> <p>Disconnect all power sources before opening the enclosure.</p>

⚠ DANGER

<p>Hazardous voltage. Moving parts. Will cause severe injury or death.</p> <p>Operate the generator set only when all guards and electrical enclosures are in place.</p>

⚠ WARNING

<p>Hazardous voltage. Backfeed to the utility system can cause property damage, severe injury, or death.</p> <p>If the generator set is used for standby power, install an automatic transfer switch to prevent inadvertent interconnection of standby and normal sources of supply.</p>

⚠ CAUTION

<p>Welding the generator set. Can cause severe electrical equipment damage.</p> <p>Never weld components of the generator set without first disconnecting the battery, controller wiring harness, and engine electronic control module (ECM).</p>

Grounding electrical equipment. Hazardous voltage will cause severe injury or death. Electrocutation is possible whenever electricity is present. Ensure you comply with all applicable codes and standards. Electrically ground the generator set, transfer switch, and related equipment and electrical circuits. Turn off the main circuit breakers of all power sources before servicing the equipment. Never contact electrical leads or appliances when standing in water or on wet ground because these conditions increase the risk of electrocution.

Welding on the generator set. Can cause severe electrical equipment damage. Before welding on the generator set perform the following steps: (1) Remove the battery cables, negative (-) lead first. (2) Disconnect all engine electronic control module (ECM) connectors. (3) Disconnect all generator set controller and voltage regulator circuit board connectors. (4) Disconnect the engine battery-charging alternator connections. (5) Attach the weld ground connection close to the weld location.

High voltage test. Hazardous voltage will cause severe injury or death. Follow the instructions of the test equipment manufacturer when performing high-voltage tests on the rotor or stator. An improper test procedure can damage equipment or lead to generator set failure.



Connecting the battery and the battery charger. Hazardous voltage will cause severe injury or death. Reconnect the battery correctly, positive to positive and negative to negative, to avoid electrical shock and damage to the battery charger and battery(ies). Have a qualified electrician install the battery(ies).

Short circuits. Hazardous voltage/current will cause severe injury or death. Short circuits can cause bodily injury and/or equipment damage. Do not contact electrical connections with tools or jewelry while making adjustments or repairs. Remove all jewelry before servicing the equipment.



Electrical backfeed to the utility. Hazardous backfeed voltage can cause severe injury or death. Install a transfer switch in standby power installations to prevent the connection of standby and other sources of power. Electrical backfeed into a utility electrical system can cause severe injury or death to utility personnel working on power lines.

Testing live electrical circuits. Hazardous voltage or current will cause severe injury or death. Have trained and qualified personnel take diagnostic measurements of live circuits. Use adequately rated test equipment with electrically insulated probes and follow the instructions of the test equipment manufacturer when performing voltage tests. Observe the following precautions when performing voltage tests: (1) Remove all jewelry. (2) Stand on a dry, approved electrically insulated mat. (3) Do not touch the enclosure or components inside the enclosure. (4) Be prepared for the system to operate automatically. *(600 volts and under)*

Heavy Equipment

 WARNING

Unbalanced weight. Improper lifting can cause severe injury or death and equipment damage.
Do not use lifting eyes. Lift the generator set using lifting bars inserted through the lifting holes on the skid.

Hot Parts

 WARNING

Hot engine and exhaust system. Can cause severe injury or death.
Do not work on the generator set until it cools.

Servicing the alternator. Hot parts can cause severe injury or death. Avoid touching the alternator field or exciter armature. When shorted, the alternator field and exciter armature become hot enough to cause severe burns.

Servicing the exhaust system. Hot parts can cause severe injury or death. Do not touch hot engine parts. The engine and exhaust system components become extremely hot during operation.

Servicing the engine heater. Hot parts can cause minor personal injury or property damage. Install the heater before connecting it to power. Operating the heater before installation can cause burns and component damage. Disconnect power to the heater and allow it to cool before servicing the heater or nearby parts.

Notice

NOTICE

Canadian installations only. For standby service connect the output of the generator set to a suitably rated transfer switch in accordance with Canadian Electrical Code, Part 1.

NOTICE

Electrostatic discharge damage. Electrostatic discharge (ESD) damages electronic circuit boards. Prevent electrostatic discharge damage by wearing an approved grounding wrist strap when handling electronic circuit boards or integrated circuits. An approved grounding wrist strap provides a high resistance (about 1 megohm), *not a direct short*, to ground.

This manual provides troubleshooting and repair instructions for the generator set models listed on the front cover. This manual may also be supplied for similar models not listed on the front cover.

Information in this publication represents data available at the time of print. Kohler Co. reserves the right to change this publication and the products represented without notice and without any obligation or liability whatsoever.

Read this manual and carefully follow all procedures and safety precautions to ensure proper equipment operation and to avoid bodily injury. Read and follow the Safety Precautions and Instructions section at the beginning of this manual.

The equipment service requirements are very important for safe and efficient operation. Inspect the parts often and perform required service at the prescribed intervals. Maintenance work must be performed by appropriately skilled and suitably trained maintenance personnel familiar with generator set operation and service.

For engine service procedures not covered in this manual, refer to the Engine Service Manual.



Figure 1 RESV/RESVL Generator Set

List of Related Materials

Separate manuals contain operation, installation, and parts information not provided in this manual. Separate engine operation and service manuals are also available. The following table lists the available manual part numbers.

Generator Set Literature	Part Number
Spec Sheet, 8RESV	G4-252
Spec Sheet, 8RESVL	G4-253
Spec Sheet, 10/12RESV	G4-254
Spec Sheet, 10/12RESVL	G4-255
Installation Manual, 8/10/12RESV/L	TP-6879
Operation Manual, 8/10/12RESV/L	TP-6880
Parts Catalog, 8/10/12RESV/L	TP-6882
Engine Literature	
Engine Service Manual, SV620, 8RESV	20 690 01
Engine Service Manual, KT725, 10/12RESV	32 690 03
Transfer Switch Literature	
Operation/Installation Manual, Model RXT Transfer Switch	TP-6807
Service/Parts Manual, Model RXT Transfer Switch	TP-6808
Operation/Installation Manual, Model RDT Transfer Switch	TP-6345
Accessory Literature	
SiteTech™ Software Operation Manual	TP-6701
OnCue® Plus Software Operation Manual	TP-6928
Instructions, Firmware Update Using USB Utility	TT-1636
Instructions, Load Shed Kit	TT-1609
Installation Instructions, Programmable Interface Module (PIM)	TT-1584

Service Assistance

For professional advice on generator set power requirements and conscientious service, please contact your nearest Kohler distributor or dealer.

- Visit the Kohler Co. website at KohlerPower.com.
- Look at the labels and decals on your Kohler product or review the appropriate literature or documents included with the product.
- Call toll free in the US and Canada 1-800-544-2444.
- Outside the US and Canada, call the nearest regional office.

Headquarters Europe, Middle East, Africa (EMEA)

Kohler Power Systems Netherlands B.V.
Kristallaan 1
4761 ZC Zevenbergen
The Netherlands
Phone: (31) 168 331630
Fax: (31) 168 331631

Asia Pacific

Power Systems Asia Pacific Regional Office
Singapore, Republic of Singapore
Phone: (65) 6264-6422
Fax: (65) 6264-6455

China

North China Regional Office, Beijing
Phone: (86) 10 6518 7950
(86) 10 6518 7951
(86) 10 6518 7952
Fax: (86) 10 6518 7955

East China Regional Office, Shanghai
Phone: (86) 21 6288 0500
Fax: (86) 21 6288 0550

India, Bangladesh, Sri Lanka

India Regional Office
Bangalore, India
Phone: (91) 80 3366208
(91) 80 3366231
Fax: (91) 80 3315972

Japan, Korea

North Asia Regional Office
Tokyo, Japan
Phone: (813) 3440-4515
Fax: (813) 3440-2727

Section 1 Specifications

1.1 Introduction

The specification sheets for each generator set provide specific generator and engine information. Refer to the generator set specification sheet for ratings and other data not supplied in this manual. Consult the generator set installation manual, engine operation manual, and engine service manual for additional specifications.

Consult the generator set nameplate for specific generator set ratings.

1.2 Controller Specifications

Model 8RESV, 10RESV, and 12RESV generator sets are equipped with the RDC2 controller. Model 8RESVL, 10RESVL, and 12RESVL generator sets are equipped with the DC2 controller. For a specific description of the controller, see the generator set operation manual.

Environmental Specification	All Models
Operating temperature	-30° to 70°C
Storage temperature	-40° to 85°C
Humidity	0-95% condensing
Power requirements:	
Voltage	12 VDC
Current (standby state)	250 mA @ 12 VDC

1.3 Engine Service

Model **8RESV(L)** Generator sets covered in this manual are equipped with four-cycle, single cylinder, air-cooled Kohler engines.

Models **10RESV(L)** and **12RESV(L)** Generator sets covered in this manual are equipped with four-cycle, twin cylinder, air-cooled Kohler engines.

For engine service information and specifications not covered in this manual, see the engine service manual. See the List of Related Materials in the Introduction section.

1.4 Engine Specifications

Engine Specification	8RESV(L)	10/12RESV(L)
Manufacturer	Kohler	
Model	SV620	KT725
Cycle	4	4
Number of cylinders	1	2
Compression ratio	8.5:1	9.0:1
Displacement, cc (cu. in.)	597 (36.4)	725 (44)
Rated power, propane fuel, kW (HP)	8 (10.7)	10RESV = 10 (13.4), 12RESV = 12 (16.1)
Rated power, natural gas, kW (HP)	7 (9.4)	10RESV = 9 (12.1), 12RESV = 11 (14.8)
Rpm, 60 Hz	3600	
Bore x stroke, mm (in.)	94 x 86 (3.7 x 3.44)	83 x 67 (3.3 x 2.6)
Valve material	Steel	
Cylinder block material	Aluminum	
Cylinder head material	Aluminum	
Piston rings	2 compression/ 1 oil	
Crankshaft material	Heat-treated ductile iron	
Main bearings: number, type	2, parent material	
Lubrication system	Full pressure	
Oil capacity (w/filter), L (qt.)	1.5 (1.6)	1.9 (2.0)
Oil pressure, kPa (psi)	172-241 (25-5)	
Fuel system	LPG or natural gas	
Minimum fuel supply pressure, kPa (in. H ₂ O)	LPG = 1.7-2.7 (7-11), NG = 0.87-2.7 (3.5-11)	
Battery voltage	12 VDC	
Battery ground	Negative	
Spark plug gap, mm (in.)	0.76 (0.030)	
Ignition system	Capacitor discharge	
Starter motor	Electric, solenoid shift	
Cooling system	Air-cooled	

1.5 Alternator Specifications

Alternator Specification	8RESV(L)	10RESV(L)	12RESV(L)
Frequency Hz	60	60	60
Phase	Single-Phase	Single-Phase	Single-Phase
Number of leads	4	4	4
Excitation method	Static Excited	Static Excited	Static Excited
Voltage regulator type	Hybrid	Hybrid	Hybrid
Coupling type	Direct	Direct	Direct
Insulation (rotor and stator)	Epoxy varnish, vacuum impregnated Class 180 (H)		
Winding material	Copper	Copper	Copper
Bearing, number and type	1, Sealed Ball	1, Sealed Ball	1, Sealed Ball
Circuit protection			
Aux. winding circuit breaker (mini-breaker)	20 amps	20 amps	20 amps
Generator AC output line circuit breaker	40 amps	50 amps	50 amps
Rotor resistance, ohms, cold	6.1	6.1	6.8
Stator resistance, ohms,* cold			
Single-Phase Leads 1-2, 3-4	.20	.20	.07
11-44	.40	.40	.14
55-66	.80	.80	.70
Stator output voltage with separately excited rotor using 12-volt battery, minimum			
Leads: 1-2, 3-4	135 V	135 V	132 V
11-44	270 V	270 V	264 V
55-66	212 V	212 V	145 V
Rotor field voltage/current readings at rated output voltage, hot			
No load	11 V/1.8 A	11 V/1.8 A	12 V/2.0 A
Full load	35 V/5.8 A	42 V/6.9 A	47 V/7.4 A
Brush length, new	19.05 mm (0.75 in.)	19.05 mm (0.75 in.)	19.05 mm (0.75 in.)
* Most ohmmeters do not give accurate readings when measuring less than 1 ohm. The stator can be considered good if a low resistance reading (continuity) is obtained and there is no evidence of shorted windings (discoloration). Do not confuse a low resistance reading with a reading indicating a shorted winding.			

1.6 Torque Specifications

Torque Specifications, Nm (ft. lb.)	8/10/12RESV(L)
Alternator overbolts	23 (17)
Alternator throbolt	33 (24)
Adapter plate bolts	53 (39)
Vibromount bolts	45 (34)
Silencer flange nuts	24.4 (18)
Oil filter	3/4 to 1 turn after gasket contact
Spark plug	24.4-29.8 (18-22)

1.7 Service View

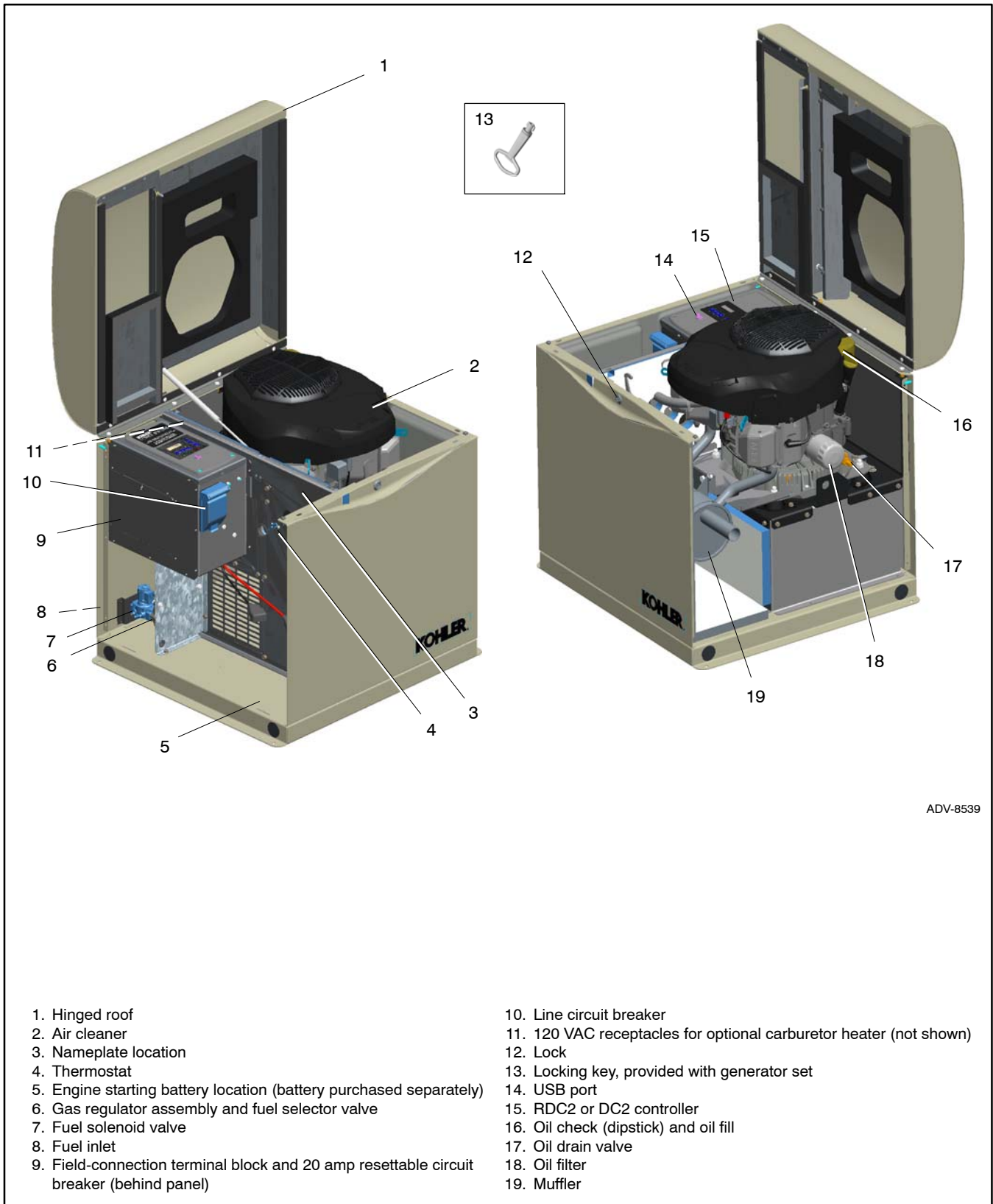
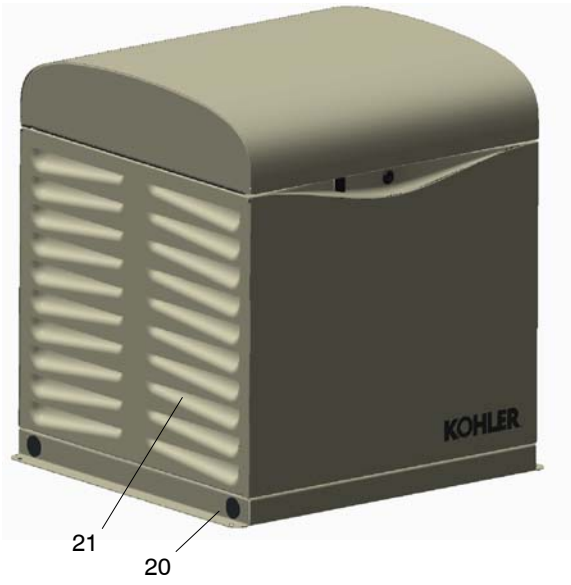

Figure 1-1 Generator Set Service View



20. Lifting holes
21. Air intake

22. Exhaust outlet

Figure 1-2 Generator Set Service View

Section 2 Scheduled Maintenance

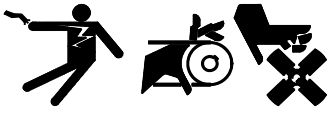
⚠ WARNING

<p>Accidental starting. Can cause severe injury or death.</p> <p>Disconnect the battery cables before working on the generator set. Remove the negative (-) lead first when disconnecting the battery. Reconnect the negative (-) lead last when reconnecting the battery.</p>

Disabling the generator set. Accidental starting can cause severe injury or death. Before working on the generator set or equipment connected to the set, disable the generator set as follows: (1) Press the generator set off/reset button to shut down the generator set. (2) Disconnect the power to the battery charger, if equipped. (3) Remove the battery cables, negative (-) lead first. Reconnect the negative (-) lead last when reconnecting the battery. Follow these precautions to prevent the starting of the generator set by the remote start/stop switch.

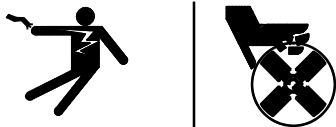
⚠ DANGER

<p>Hazardous voltage. Will cause severe injury or death.</p> <p>This equipment must be installed and serviced by qualified electrical personnel.</p>

⚠ DANGER

<p>Hazardous voltage. Moving parts. Will cause severe injury or death.</p> <p>Operate the generator set only when all guards and electrical enclosures are in place.</p>

⚠ WARNING

<p>Hot engine and exhaust system. Can cause severe injury or death.</p> <p>Do not work on the generator set until it cools.</p>

Servicing the alternator. Hot parts can cause severe injury or death. Avoid touching the alternator field or exciter armature. When shorted, the alternator field and exciter armature become hot enough to cause severe burns.

Servicing the exhaust system. Hot parts can cause severe injury or death. Do not touch hot engine parts. The engine and exhaust system components become extremely hot during operation.

Servicing the engine heater. Hot parts can cause minor personal injury or property damage. Install the heater before connecting it to power. Operating the heater before installation can cause burns and component damage. Disconnect power to the heater and allow it to cool before servicing the heater or nearby parts.

⚠ WARNING

<p>Risk of fire. Can cause severe injury or death.</p> <p>Do not smoke or permit flames or sparks near fuels or the fuel system.</p>

Servicing the air cleaner. A sudden backfire can cause severe injury or death. Do not operate the generator set with the air cleaner removed.

Servicing the fuel system. A flash fire can cause severe injury or death. Do not smoke or permit flames or sparks near the carburetor, fuel line, fuel filter, fuel pump, or other potential sources of spilled fuels or fuel vapors. Catch fuels in an approved container when removing the fuel line or carburetor.

The fuel system. Explosive fuel vapors can cause severe injury or death. Vaporized fuels are highly explosive. Use extreme care when handling and storing fuels. Store fuels in a well-ventilated area away from spark-producing equipment and out of the reach of children. Never add fuel to the tank while the engine is running because spilled fuel may ignite on contact with hot parts or from sparks. Do not smoke or permit flames or sparks to occur near sources of spilled fuel or fuel vapors. Keep the fuel lines and connections tight and in good condition. Do not replace flexible fuel lines with rigid lines. Use flexible sections to avoid fuel line breakage caused by vibration. Do not operate the generator set in the presence of fuel leaks, fuel accumulation, or sparks. Repair fuel systems before resuming generator set operation.

Gas fuel leaks. Explosive fuel vapors can cause severe injury or death. Fuel leakage can cause an explosion. Check the LPG vapor or natural gas fuel system for leakage by using a soap and water solution with the fuel system test pressurized to 6–8 ounces per square inch (10–14 inches water column). Do not use a soap solution containing either ammonia or chlorine because both prevent bubble formation. A successful test depends on the ability of the solution to bubble.

LPG liquid withdrawal fuel leaks. Explosive fuel vapors can cause severe injury or death. Fuel leakage can cause an explosion. Check the LPG liquid withdrawal fuel system for leakage by using a soap and water solution with the fuel system test pressurized to at least 90 psi (621 kPa). Do not use a soap solution containing either ammonia or chlorine because both prevent bubble formation. A successful test depends on the ability of the solution to bubble.

See the Safety Precautions and Instructions at the beginning of this manual before attempting to service, repair, or operate the generator set. Have an authorized distributor/dealer perform generator set service.

Alternator Service. Under normal operating conditions the generator set alternator does not require scheduled service. Refer to the service schedule for items that require maintenance.

Engine Service. Perform generator set engine service at the intervals specified by the engine service literature. Contact an authorized Kohler® service distributor/dealer to obtain engine service literature.

All generator sets have emission-certified engines. The carburetors on emission-certified engines are not adjustable.

Routine Maintenance. Refer to the following generator set service schedule, the engine service schedule, and the runtime hours displayed on the generator set controller to determine when to schedule routine maintenance. Service the generator set more frequently if it is subject to extreme weather, long operating hours, or dusty or dirty conditions.

Maintenance Reminders. The RDC2 and DC2 controllers display a reminder message every 100 hours of engine run time. Change the oil and perform other maintenance tasks listed on the service schedule. Then reset the reminder. See Section 2.2.5 for instructions to reset the maintenance reminder.

Service Schedule. Perform maintenance on each item in the service schedule at the designated interval for the life of the generator set.

Tools. Tools and instruments used to perform some maintenance items are not generally available to the generator set owner. Therefore, have service performed by an authorized distributor/dealer.

2.1 Service Schedule

Refer to the following service schedules and the runtime hours displayed on the controller display to schedule routine maintenance. Intervals are shown in hours of operation and/or time intervals (i.e. weekly, monthly, quarterly, etc.) Have an authorized distributor/dealer service the generator set at the designated intervals in the service schedule for the life of the generator set. Service units subject to extreme weather, long operating hours, or dusty or dirty conditions more frequently.

Contact an authorized distributor/dealer for parts.

2.1.1 Service Schedule

System Component or Procedure	See Section	Visually Inspect	Check	Change	Clean	Test	Frequency
Fuel							
Flexible lines and connections		X		R			Quarterly
Main tank supply level			X				Weekly
Fuel piping		X					Yearly
Lubrication							
	2.2						
Oil level		X	X				8 hours or before use
Crankcase breather hose		X					Yearly or 500 hours
Change oil				X			Yearly or 100 hours
Replace filter				X			Yearly or 100 hours
Cooling							
	2.5						
Air ducts, louvers			X		X		Yearly
Exhaust Line							
	2.6						
Leakage		X	X				Weekly
Insulation, fire hazards		X					Yearly
Obstructions or combustible materials near exhaust outlet		X					Weekly
DC Electrical System							
	2.9						
Battery charger operation, charge rate (if equipped)		X					Monthly
Remove corrosion, clean and dry battery and rack		X			X		Yearly
Clean and tighten battery terminals and inspect boots		X	X				Yearly
Battery electrolyte level and specific gravity *			X				Yearly
AC Electrical System							
Tighten control and power wiring connections			X				Yearly
Remote control system, if equipped						X	Monthly
Visible wear or damage		X					Quarterly
Wire abrasions where subject to motion		X	X				Six Months
Wire-cable insulation condition		X					3 Years or 500 hours
Engine and Mounting							
Visible wear or damage		X					Weekly
Air cleaner service †	2.4		150	300			Yearly or hours shown
Spark plugs (apply anti-seize lubricant for easy removal)	2.3			X			Yearly or 500 hours
Checked/adjusted valve lash, 8RESV(L)	Engine SM			D			100 hours
Checked/adjusted valve lash, 10/12RESV(L)	Engine SM			D			500 hours
Replace stepper motor coupling and bushing				D			500 hours
Generator							
Visible wear or damage		X					Quarterly
Exercise generator set						X	Weekly
Measure and record resistance readings of windings with insulation tester (Megger®, with SCR assembly or rectifier and load leads disconnected) *						D	3 Years
General Condition of Equipment							
Evidence of vibration, leakage, excessive noise, temperature, or deterioration		X	X		X		Weekly
Interior of sound enclosure		X			X		Quarterly
* Not necessary for maintenance-free batteries.		X Action					
† Service more frequently under extremely dusty/dirty conditions.		D Authorized distributor/dealer only					
Megger® is a registered trademark of Biddle Instruments.		R Replace as necessary					

2.2 Lubrication System

See the service schedules in Section 2.1 for oil change and oil filter replacement intervals. See the service views in Section 1 for the oil drain, oil check, oil fill, and oil filter locations.

2.2.1 Low Oil Pressure Shutdown

The low oil pressure (LOP) shutdown feature protects the engine against internal damage if the oil pressure drops below a minimum pressure because of oil pump failure or other malfunction.

Note: The LOP shutdown feature does not protect against damage caused by operating when the oil level is low; it is not a low oil level shutdown. Check the oil level regularly, and add oil as needed.

2.2.2 Oil Check

The generator set is shipped with oil. Before operating the generator set, check the engine oil in the crankcase.

To check the oil level, shut down the generator set and wait several minutes. Remove the dipstick and wipe the end clean, reinsert, and remove. See Figure 2-1. Maintain the oil level between the Add and Full marks on the dipstick. Add 5W-30 synthetic oil when the oil level is low.

Check the oil level before each use. For extended operation, check the oil level every 8 hours. Do not check the oil level when the generator set is running.

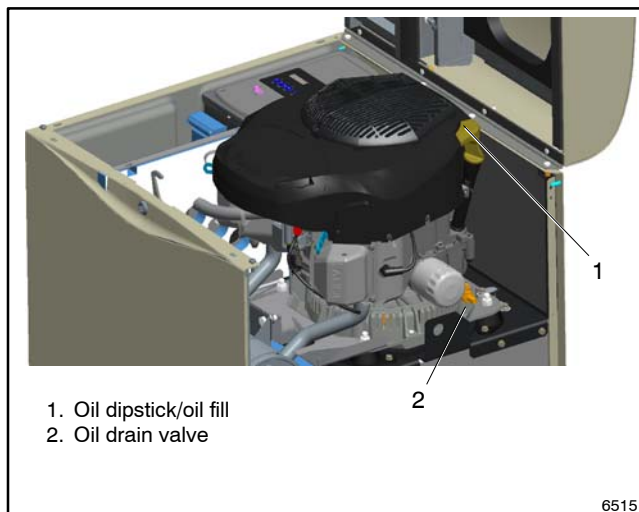
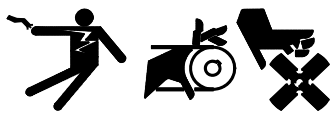

Figure 2-1 Oil Check (typical)

2.2.3 Engine Oil Recommendation

Use 5W-30 API (American Petroleum Institute) Service Class SG, SH, or SJ synthetic oil. Synthetic oil oxidizes and thickens less than other oils and leaves the engine intake valves and pistons cleaner.

2.2.4 Oil Change Procedure

⚠ WARNING

Accidental starting. Can cause severe injury or death.
Disconnect the battery cables before working on the generator set. Remove the negative (-) lead first when disconnecting the battery. Reconnect the negative (-) lead last when reconnecting the battery.

Disabling the generator set. Accidental starting can cause severe injury or death. Before working on the generator set or equipment connected to the set, disable the generator set as follows: (1) Press the generator set off/reset button to shut down the generator set. (2) Disconnect the power to the battery charger, if equipped. (3) Remove the battery cables, negative (-) lead first. Reconnect the negative (-) lead last when reconnecting the battery. Follow these precautions to prevent the starting of the generator set by the remote start/stop switch.

⚠ WARNING

Risk of fire. Can cause severe injury or death.
Do not smoke or permit flames or sparks near fuels or the fuel system.

Servicing the fuel system. A flash fire can cause severe injury or death. Do not smoke or permit flames or sparks near the carburetor, fuel line, fuel filter, fuel pump, or other potential sources of spilled fuels or fuel vapors. Catch fuels in an approved container when removing the fuel line or carburetor.

Note: Dispose of all waste materials (engine oil, fuel, filter, etc.) in an environmentally safe manner.

Note: The oil change procedure requires the use of rags, a drain tube, and a funnel. Follow the instructions and use caution to prevent oil from spilling on or into the alternator.

1. Drain the oil.

- a. Press the OFF button on the generator set controller.
- b. Disconnect the utility power to the generator set.
- c. Disconnect the generator set engine starting battery, negative (-) lead first.
- d. Remove the side panel on the exhaust side of the enclosure.
- e. Clean the area around the dipstick and oil fill cap.
- f. To prevent oil from spilling into the alternator, completely cover the alternator with rags around the areas near the oil drain valve and oil filter.
- g. Insert a drain tube (3/8 in. inside diameter) onto the oil drain valve and place the end of the tube into a drain pan. The tube will reduce the potential for spilled oil.
- h. Open the oil drain valve on the engine.
- i. Remove the dipstick and oil fill cap. Allow time for the engine oil to drain completely.
- j. Close the oil drain valve and remove the oil drain tube.
- k. Replace the dipstick.

2. Replace the oil filter.

- a. Clean the area around the oil filter.
- b. Loosen the oil filter by rotating it counterclockwise with an oil filter wrench.
- c. As you remove the oil filter, tilt the filter upward to prevent oil from spilling.
- d. Clean the gasket sealing surface of the oil filter adapter.
- e. Apply a light coat of clean oil to the rubber seal of the new oil filter.

- f. Lightly thread the new oil filter by hand until you feel Resistance. Then, tighten the filter an additional 3/4 turn with an oil filter wrench.

3. Fill with oil.

Note: When the oil is drained, some oil remains in the engine. The amount of oil needed to refill the engine may be less than the capacity shown in Figure 2-2. Use the dipstick shown in Figure 2-1 to check the oil level during the fill. Do not fill past the full mark on the dipstick.

Generator Set Model	Oil Capacity, L (qt.)
8RESV/RESVL	1.5 (1.6)
10/12RESV/RESVL	1.9 (2.0)

Figure 2-2 Engine Oil Capacity (new, dry engine)

- a. See Section 2.2.3 for the recommended oil type. To prevent spilling, use a funnel to add oil through the oil fill port. Use the dipstick to check the oil level before starting to add the final quart of oil. Fill the engine to the F mark on the dipstick.
- b. Reinstall the dipstick and the oil fill cap.
- c. Remove all rags near the alternator and oil drain valve.
- d. Reconnect the generator set engine starting battery, negative (-) lead last.
- e. Reconnect the utility power to the generator set.
- f. Press the RUN button on the generator set controller. The generator set will start.
- g. Run the generator set for a minute to allow the oil pressure to reach operating range.
- h. Stop the generator set, wait 1 minute, and then recheck the oil level. Add oil to bring the level up to the F mark on the dipstick.

4. Check for leaks.

- a. Check for oil leaks.
- b. Fix leaks and recheck the oil level.
- c. Reinstall the side panel.

5. Reset the maintenance timer on the controller.

2.2.5 Resetting the Maintenance Timer

Model RESV (RDC2):

1. From the Overview menu, step down to the Genset Run Time menu.
2. Press the Select button and then step down to the Next Maintenance screen.
3. Press the Select button.
4. Press the Up arrow button so that "Reset Maint Timer? Yes" is displayed.
5. Press the Select button. **After about 2 minutes**, the new maintenance interval and date are displayed.

Model RESVL (DC2):

1. Press and hold the OFF and AUTO buttons together until Maintenance Timer Reset is displayed.
2. Release the OFF and AUTO buttons.

2.3 Spark Plugs

⚠ WARNING



Airborne particles.
Can cause severe injury or blindness.

Wear protective goggles and clothing when using power tools, hand tools, or compressed air.

⚠ WARNING

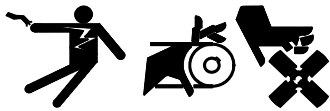

Accidental starting.
Can cause severe injury or death.

Disconnect the battery cables before working on the generator set. Remove the negative (-) lead first when disconnecting the battery. Reconnect the negative (-) lead last when reconnecting the battery.

Disabling the generator set. Accidental starting can cause severe injury or death. Before working on the generator set or equipment connected to the set, disable the generator set as follows: (1) Press the generator set off/reset button to shut down the generator set. (2) Disconnect the power to the battery charger, if equipped. (3) Remove the battery cables, negative (-) lead first. Reconnect the negative (-) lead last when reconnecting the battery. Follow these precautions to prevent the starting of the generator set by the remote start/stop switch.

Reset the spark plug gap or replace the plugs with new plugs as necessary.

Note: To avoid stripping the threads, allow the engine to cool before removing the spark plugs.

1. Clean the area around the base of the spark plug to keep dirt and debris out of the engine.
2. Remove the spark plug and check its condition. Replace the spark plug if it is worn or if its reuse is questionable.
3. Check the spark plug gap using a wire feeler gauge. See Figure 2-3 for the recommended spark plug gap. Adjust the gap by carefully bending the ground electrode. See Figure 2-4 and Figure 2-5.
4. For easy removal, apply a light coating of anti-seize lubricant to the cleaned spark plug threads. Wipe away any excess compound.
5. Reinstall the spark plug into the cylinder head. Torque the spark plug to 24.4–29.8 Nm (18–22 ft. lb.)

Generator Set Model	Spark Plug Gap
8/10/12RESV/RESVL	0.76 mm (0.030 in.)

Figure 2-3 Spark Plug Gap

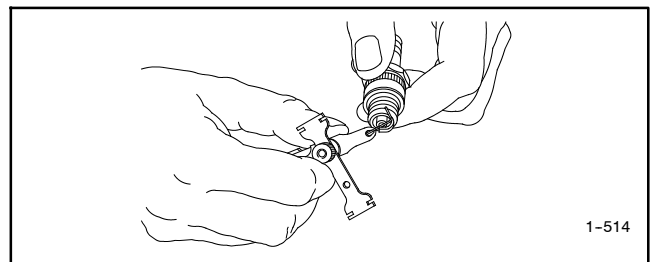

Figure 2-4 Checking the Spark Plug Gap

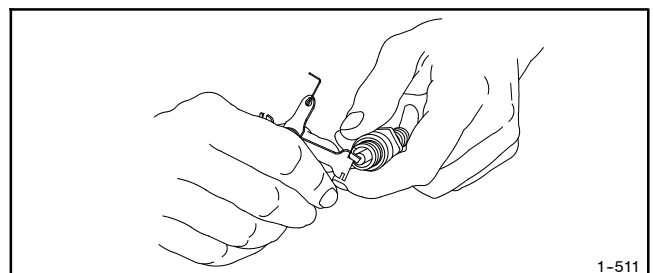
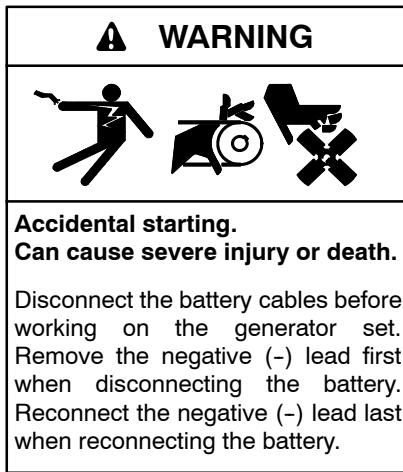
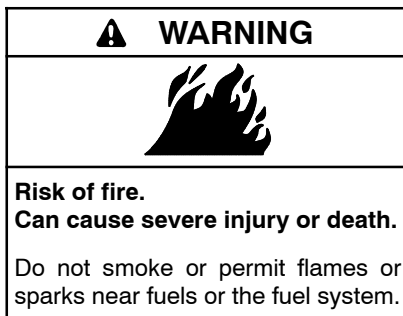

Figure 2-5 Adjusting the Spark Plug Gap

2.4 Air Cleaner Service



Disabling the generator set. Accidental starting can cause severe injury or death. Before working on the generator set or equipment connected to the set, disable the generator set as follows: (1) Press the generator set off/reset button to shut down the generator set. (2) Disconnect the power to the battery charger, if equipped. (3) Remove the battery cables, negative (-) lead first. Reconnect the negative (-) lead last when reconnecting the battery. Follow these precautions to prevent the starting of the generator set by the remote start/stop switch.



Servicing the air cleaner. A sudden backfire can cause severe injury or death. Do not operate the generator set with the air cleaner removed.

2.4.1 Air Cleaner, 8RESV/RESVL Models

The engine has a replaceable high-density paper air cleaner element. See Figure 2-6.

Check for a buildup of dirt and debris around the air cleaner system. Keep this area clean. Also check for loose or damaged components. Replace all bent or damaged air cleaner components.

Note: Operating the engine with loose or damaged air cleaner components could allow unfiltered air into the engine causing premature wear and failure.

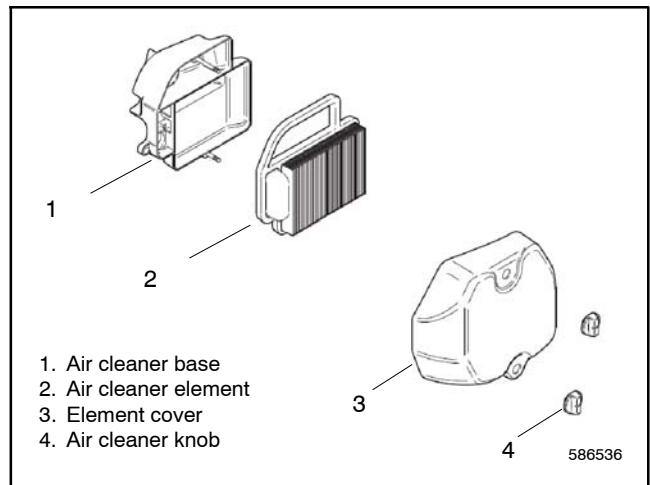

Figure 2-6 Air Cleaner Components

Paper Element Service

Use the following procedure to replace the paper element at the intervals specified in the service schedule. Replace the paper element more often under extremely dusty or dirty conditions.

1. Press the OFF button on the generator set controller.
2. Disconnect the utility power to the generator set.
3. Disconnect the generator set engine starting battery, negative (-) lead first.
4. Loosen the cover retaining knobs and remove the cover.
5. Remove the paper element.

Note: Do not wash the paper element or clean it with pressurized air, as this will damage the element.

6. Replace the element if it is dirty, bent, or damaged.
7. Check the air cleaner base. Make sure it is secure and not bent or damaged. Also check the element cover for damage and fit. Replace all damaged air cleaner components. Remove any loose dirt or debris from the air cleaner base. Wipe the base carefully so that no dirt drops into the intake throat. Check the condition of the rubber seal on the air cleaner stud and replace the seal if necessary.
8. Reinstall the paper element and the air cleaner cover. Secure the cover with the cover retaining knobs.
9. Reconnect the utility power to the generator set.
10. Reconnect the generator set engine starting battery, negative (-) lead last.

2.4.2 Air Cleaner, 10/12RESV/RESVL Models

The engine is equipped with a replaceable, high density paper air cleaner element. See Figure 2-7.

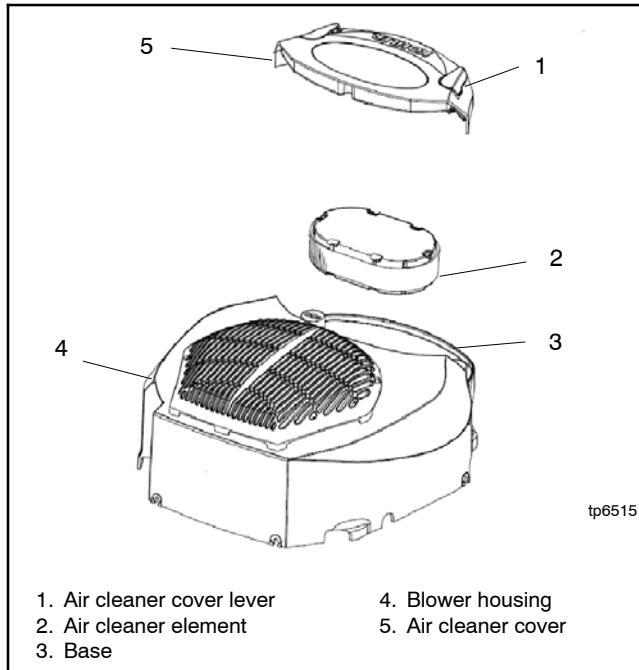

Figure 2-7 Air Cleaner Components

Check the air cleaner daily or before starting the engine. Check for a buildup of dirt and debris around the air cleaner system. Keep this area clean. Also check for loose or damaged components. Replace all bent or damaged air cleaner components.

Note: Operating the engine with loose or damaged air cleaner components could allow unfiltered air into the engine causing premature wear and failure.

Paper Element Service

Replace the paper element at the intervals indicated in the service schedule. See Figure 2-7 for the air cleaner components.

1. Press the OFF button on the generator set controller.
2. Disconnect the utility power to the generator set.
3. Disconnect the generator set engine starting battery, negative (-) lead first.
4. Rotate the air cleaner cover levers outward to unlock cover; remove the air cleaner cover.
5. Remove the paper element from the base.
6. Do not wash the paper element or use pressurized air, as this will damage the element. Replace a dirty, bent, or damaged element. Handle new elements carefully; do not use if the sealing surfaces are bent or damaged.
7. When servicing the air cleaner, check the air cleaner base. Make sure it is secured and not bent or damaged. Also, check the element cover for damage or improper fit. Replace all damaged air cleaner components.

Note: If any loose dirt or debris fell on the air cleaner base when the element was removed, carefully remove it and wipe the base clean. Be careful that none of it drops into the intake throat.

8. Reinstall the paper element onto the air cleaner base. Make sure the element is flat and properly seated.
9. Position the air cleaner cover with levers outward over air cleaner; turn levers inward to lock.
10. When element replacement is necessary, order genuine Kohler parts.
11. Reconnect the power to the battery charger.
12. Reconnect the generator set engine starting battery, negative (-) lead last.

2.5 Cooling System

The engine fan draws cooling air through the openings in the sides and end near the battery. The alternator fan draws cooling air through openings on the side walls of the enclosure. The cooling air mixes with the engine exhaust and is discharged at the exhaust outlet. See the service view in Section 1 for air intake and exhaust locations. To prevent generator set damage caused by overheating, keep the housing cooling inlets and outlets clean and unobstructed at all times.

Note: Do not block the generator set cooling air inlets or mount other equipment above them. Overheating and severe generator damage may occur.

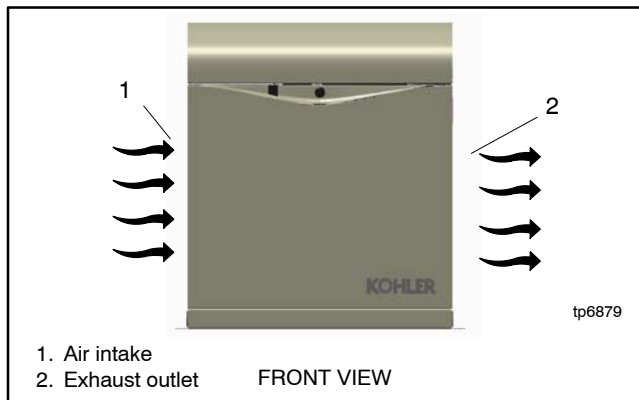
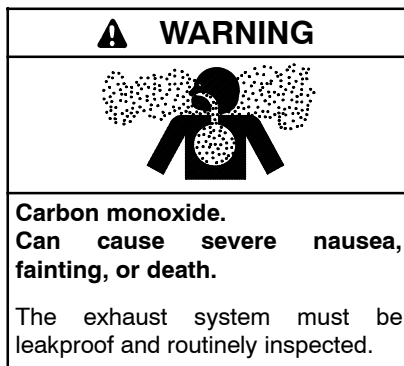

Figure 2-8 Cooling Air Intake and Exhaust

2.6 Exhaust System



Generator set operation. Carbon monoxide can cause severe nausea, fainting, or death. Carbon monoxide is an odorless, colorless, tasteless, nonirritating gas that can cause death if inhaled for even a short time. Avoid breathing exhaust fumes when working on or near the generator set. Never operate the generator set inside a building. Never operate the generator set where exhaust gas could seep inside or be drawn into a potentially occupied building through windows, air intake vents, or other openings.

Carbon monoxide detectors. Carbon monoxide can cause severe nausea, fainting, or death. Install carbon monoxide detectors on each level of any building adjacent to the generator set. Locate the detectors to adequately warn the building's occupants of the presence of carbon monoxide. Keep the detectors operational at all times. Periodically test and replace the carbon monoxide detectors according to the manufacturer's instructions.

Carbon monoxide symptoms. Carbon monoxide can cause severe nausea, fainting, or death. Carbon monoxide is a poisonous gas present in exhaust gases. Carbon monoxide is an odorless, colorless, tasteless, nonirritating gas that can cause death if inhaled for even a short time. Carbon monoxide poisoning symptoms include but are not limited to the following:

- Light-headedness, dizziness
- Physical fatigue, weakness in joints and muscles
- Sleepiness, mental fatigue, inability to concentrate or speak clearly, blurred vision
- Stomachache, vomiting, nausea

If experiencing any of these symptoms and carbon monoxide poisoning is possible, seek fresh air immediately and remain active. Do not sit, lie down, or fall asleep. Alert others to the possibility of carbon monoxide poisoning. Seek medical attention if the condition of affected persons does not improve within minutes of breathing fresh air.

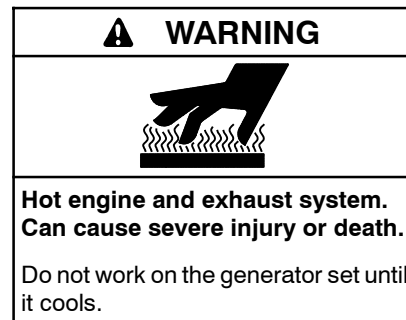
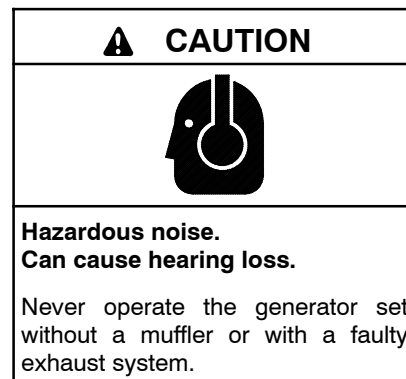

Servicing the exhaust system. Hot parts can cause severe injury or death. Do not touch hot engine parts. The engine and exhaust system components become extremely hot during operation.

Remove all combustible materials from the exhaust location. Combustible materials include building materials as well as natural surroundings. Keep dry field grass, foliage, and combustible landscaping material a minimum of 1.5 m (5 ft.) from the exhaust outlet.

Periodically inspect the exhaust system components for cracks, leaks, and corrosion.

- Check for corroded or broken metal parts and replace them as needed.
- Check that the exhaust outlet is clear.

2.7 Stepper Motor Coupling

Replace the stepper motor coupling and bushings at the intervals shown in the service schedule. See the Parts Catalog for replacement part numbers.

Figure 2-9 shows the location of the coupling assembly under the air cleaner. Loosen the set screw to remove the coupling from the motor shaft.

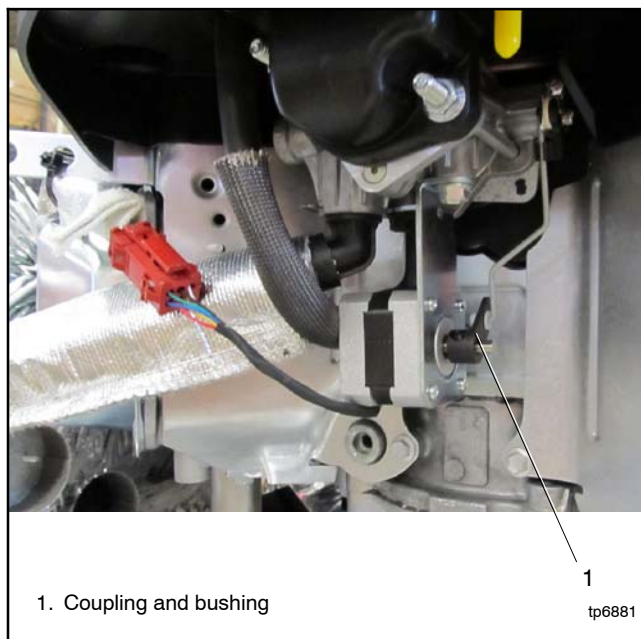

Figure 2-9 Stepper Motor Coupling

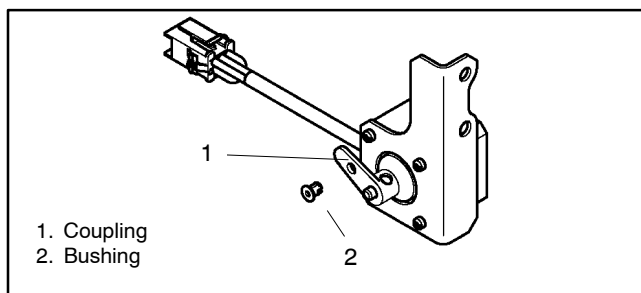
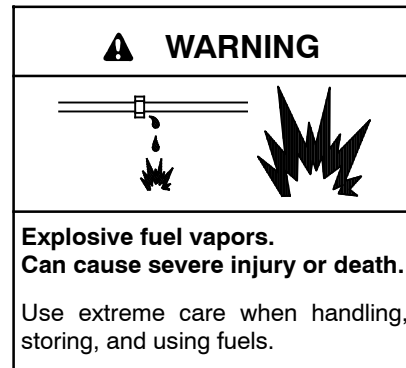

Figure 2-10 Stepper Motor Coupling and Bushing

2.8 Fuel System Maintenance



The fuel system. Explosive fuel vapors can cause severe injury or death. Vaporized fuels are highly explosive. Use extreme care when handling and storing fuels. Store fuels in a well-ventilated area away from spark-producing equipment and out of the reach of children. Never add fuel to the tank while the engine is running because spilled fuel may ignite on contact with hot parts or from sparks. Do not smoke or permit flames or sparks to occur near sources of spilled fuel or fuel vapors. Keep the fuel lines and connections tight and in good condition. Do not replace flexible fuel lines with rigid lines. Use flexible sections to avoid fuel line breakage caused by vibration. Do not operate the generator set in the presence of fuel leaks, fuel accumulation, or sparks. Repair fuel systems before resuming generator set operation.

Gas fuel leaks. Explosive fuel vapors can cause severe injury or death. Fuel leakage can cause an explosion. Check the LPG vapor or natural gas fuel system for leakage by using a soap and water solution with the fuel system test pressurized to 6–8 ounces per square inch (10–14 inches water column). Do not use a soap solution containing either ammonia or chlorine because both prevent bubble formation. A successful test depends on the ability of the solution to bubble.

LPG liquid withdrawal fuel leaks. Explosive fuel vapors can cause severe injury or death. Fuel leakage can cause an explosion. Check the LPG liquid withdrawal fuel system for leakage by using a soap and water solution with the fuel system test pressurized to at least 90 psi (621 kPa). Do not use a soap solution containing either ammonia or chlorine because both prevent bubble formation. A successful test depends on the ability of the solution to bubble.

2.9 Battery

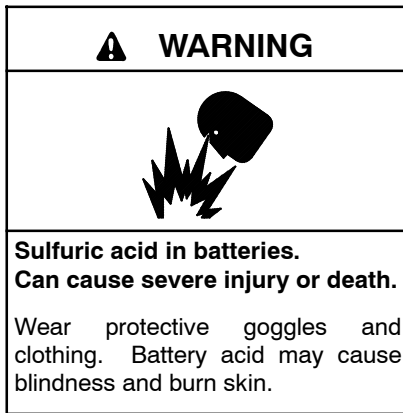

Battery electrolyte is a diluted sulfuric acid. Battery acid can cause severe injury or death. Battery acid can cause blindness and burn skin. Always wear splashproof safety goggles, rubber gloves, and boots when servicing the battery. Do not open a sealed battery or mutilate the battery case. If battery acid splashes in the eyes or on the skin, immediately flush the affected area for 15 minutes with large quantities of clean water. Seek immediate medical aid in the case of eye contact. Never add acid to a battery after placing the battery in service, as this may result in hazardous spattering of battery acid.

Battery acid cleanup. Battery acid can cause severe injury or death. Battery acid is electrically conductive and corrosive. Add 500 g (1 lb.) of bicarbonate of soda (baking soda) to a container with 4 L (1 gal.) of water and mix the neutralizing solution. Pour the neutralizing solution on the spilled battery acid and continue to add the neutralizing solution to the spilled battery acid until all evidence of a chemical reaction (foaming) has ceased. Flush the resulting liquid with water and dry the area.

Battery gases. Explosion can cause severe injury or death. Battery gases can cause an explosion. Do not smoke or permit flames or sparks to occur near a battery at any time, particularly when it is charging. Do not dispose of a battery in a fire. To prevent burns and sparks that could cause an explosion, avoid touching the battery terminals with tools or other metal objects. Remove all jewelry before servicing the equipment. Discharge static electricity from your body before touching batteries by first touching a grounded metal surface away from the battery. To avoid sparks, do not disturb the battery charger connections while the battery is charging. Always turn the battery charger off before disconnecting the battery connections. Ventilate the compartments containing batteries to prevent accumulation of explosive gases.

Battery short circuits. Explosion can cause severe injury or death. Short circuits can cause bodily injury and/or equipment damage. Disconnect the battery before generator set installation or maintenance. Remove all jewelry before servicing the equipment. Use tools with insulated handles. Remove the negative (-) lead first when disconnecting the battery. Reconnect the negative (-) lead last when reconnecting the battery. Never connect the negative (-) battery cable to the positive (+) connection terminal of the starter solenoid. Do not test the battery condition by shorting the terminals together.

Refer to this section for general battery information and maintenance. Also consult the battery manufacturer's instructions for battery maintenance.

All generator set models use a negative ground with a 12-volt engine electrical system. Consult the generator set nameplate for the engine electrical system voltage. Consult the generator spec sheet for battery capacity recommendations for replacement purposes. Wiring diagrams provide battery connection information. See Figure 2-11 for typical battery connections.

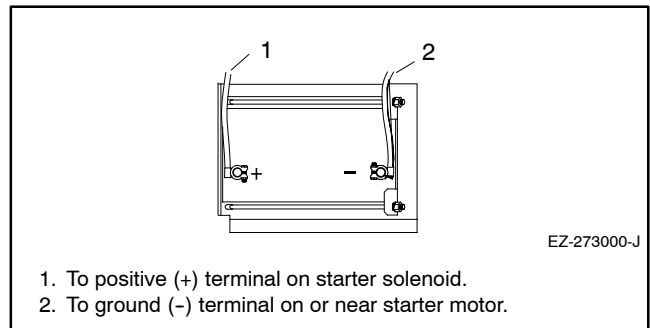

Figure 2-11 12-Volt Engine Electrical System Single Starter Motor, Typical Battery Connection

Clean the battery and cables and tighten battery terminals using the service schedule recommendations. To prevent corrosion, maintain tight, dry electrical connections at the battery terminals. To remove corrosion from battery terminals, disconnect the cables from the battery and scrub the terminals with a wire brush. Clean the battery and cables with a solution of baking soda and water. After cleaning, flush the battery and cables with clean water and wipe them with a dry, lint-free cloth.

After reconnecting the battery cables, coat the battery terminals with petroleum jelly, silicone grease, or other nonconductive grease.

2.9.1 Checking Electrolyte Level

Check the electrolyte level of batteries with filler caps monthly. Remove filler caps and verify that electrolyte level reaches bottom of filler holes. Refill as necessary with distilled water. DO NOT add fresh electrolyte. Tighten all filler caps. If water is added during freezing temperatures, run the generator set for 20–30 minutes to mix the electrolyte and water to prevent battery damage from freezing.

2.9.2 Checking Specific Gravity

Use a battery hydrometer to check the specific gravity of the electrolyte in each battery cell. While holding the hydrometer vertically, read the number on the glass bulb at the top of the electrolyte level or the number adjacent to the pointer. If the hydrometer used does not have a correction table, use the correction factors in Figure 2-14. Determine specific gravity and electrolyte temperature of battery cells. Locate temperature in Figure 2-14 and adjust the specific gravity by the amount shown.

The battery is fully charged if the specific gravity is 1.260 at an electrolyte temperature of 80°F (26.7°C). The difference between specific gravities of each cell should not exceed ±0.01. Charge the battery if the specific gravity is below 1.215 at an electrolyte temperature of 80°F (26.7°C). See Figure 2-12.

Specific Gravity, Corrected to 80°F (26.7°C)	Battery Condition
Below 1.215	Needs charging
1.260	Fully charged

Figure 2-12 Specific Gravity Interpretation

Some battery testers have four or five beads in the test tube. Draw electrolyte into the tube as performed with the battery hydrometer described previously. Use the manufacturer’s instructions. Figure 2-13 interprets typical test results.

Number of Floating Beads	Battery Condition
5	Overcharged
4	Fully charged
3	Good charge
1 or 2	Low charge
0	Dead battery

Figure 2-13 Bead-Type Test Interpretation

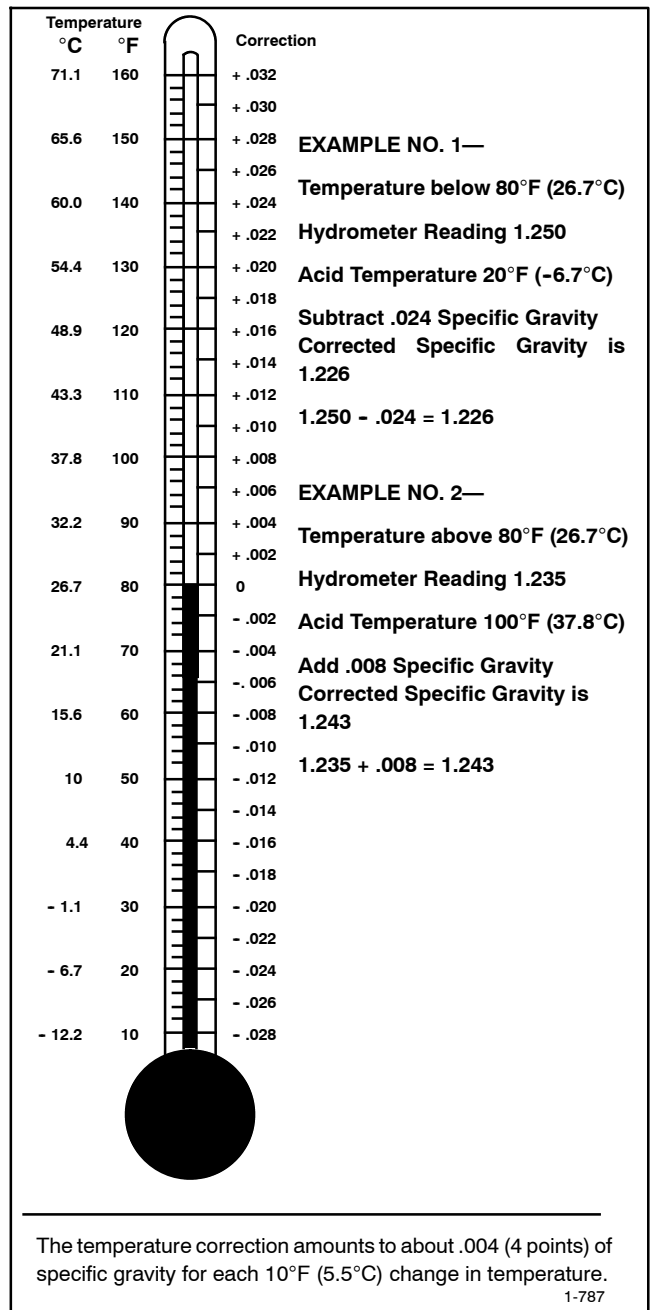

Figure 2-14 Specific Gravity Temperature Correction

2.10 Storage Procedure

Perform the following storage procedure before removing the generator set from service for three months or longer. Follow the engine manufacturer's recommendations for storage, if available.

Note: Run the generator set monthly whenever possible.

2.10.1 Lubricating System

1. Operate the generator set until it reaches operating temperature, or about 15 minutes.
2. Stop the generator set.
3. While the engine is still warm, drain the engine lubrication oil from the engine crankcase.
4. Refill engine crankcase with oil. See Section 2.2.3 for oil recommendations.
5. Run the generator set for a few minutes to distribute the clean oil.
6. Stop the generator set.

2.10.2 Fuel System

1. Start the generator set.
2. With the generator set running, shut off the gas supply.
3. Run the generator set until the engine stops.
4. Press the OFF button on the generator set controller.

2.10.3 Cylinder Lubrication

1. Remove the spark plugs.
2. Pour one tablespoon of engine oil into each spark plug hole. Install the spark plugs and *ground* the spark plug leads. *Do not connect the leads to the plugs.*
3. Crank the engine two or three revolutions to lubricate the cylinders.

2.10.4 Exterior Preparation

1. Clean the exterior surface of the generator set.
2. Seal all openings in the engine with nonabsorbent adhesive tape.
3. Mask all areas to be used for electrical contact.
4. Spread a light film of oil over unpainted metallic surfaces to prevent rust and corrosion.

2.10.5 Battery

Perform battery storage last.

1. Press the OFF button on the generator set controller.
2. Disconnect the battery, negative (-) lead first.
3. Clean the battery.
4. Place the battery in a warm, dry location.
5. Connect the battery to a float/equalize battery charger, or charge the battery monthly using a trickle charger. Follow the battery charger manufacturer's recommendations.

Notes

3.1 Introduction

The RDC2 and DC2 controllers manage the operation of the generator set, a Model RXT transfer switch (if equipped), the optional Programmable Interface Module (PIM), and optional load management device. See the generator set Operation Manual for controller operation instructions.

This section covers adjustment and replacement of the RDC2 and DC2 controllers. See Section 4.12 for troubleshooting information.

The RDC2 and DC2 controllers are shown in Figure 3-1. See the service view for the controller location.

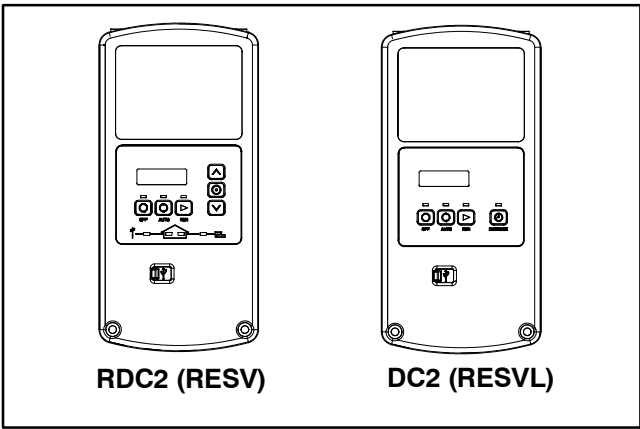

Figure 3-1 Controllers

3.2 SiteTech and OnCue Plus Software

Many procedures in this manual require the use of a personal computer (or laptop) with Kohler® SiteTech™ software to change controller settings or update firmware. SiteTech software is available to Kohler-authorized distributors and dealers. See the SiteTech Operation Manual, TP-6701, for general software operation instructions.

Use a USB cable to connect the personal computer directly to the device. See Figure 3-3. The USB cable must have a male USB A connector on one end and a male mini-B connector on the other and must be less than 5 m (16.4 ft.) long. See Figure 3-2.



Figure 3-2 USB Cable

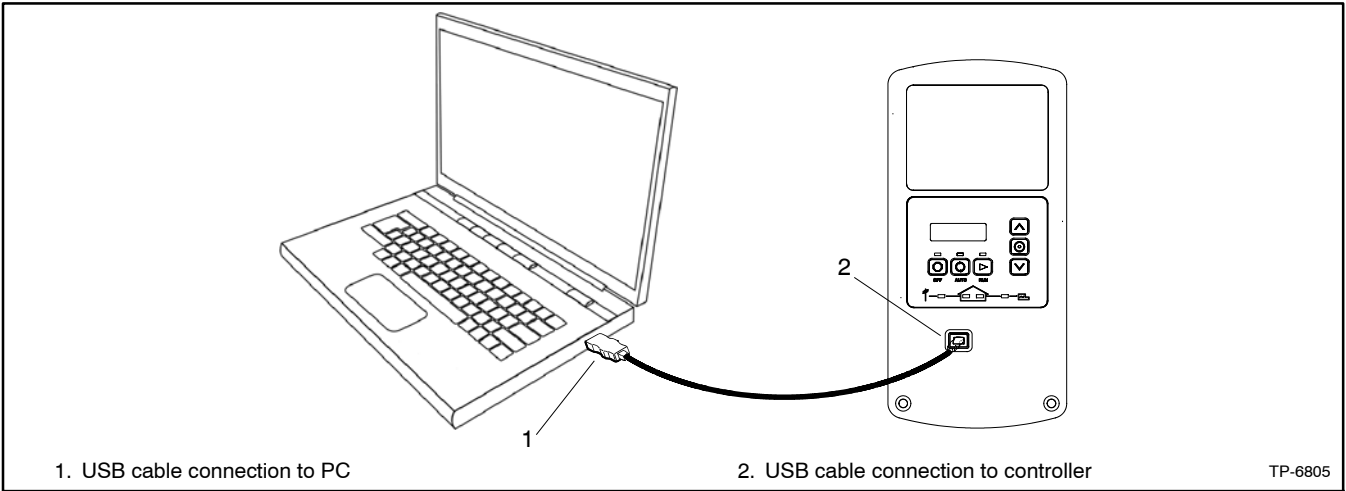

Figure 3-3 USB Connection (RDC2 controller shown)

3.3 Controller Parameters

Adjustable parameter settings can be changed using a personal computer (or laptop) with Kohler® SiteTech™ software. See Section 3.2, SiteTech Software, for USB connection information. See the SiteTech Operation Manual, TP-6701, for general software operation instructions.

Some parameter settings can also be changed at the RDC2 controller. See the generator set operation manual for instructions to navigate through the controller menus and change settings.

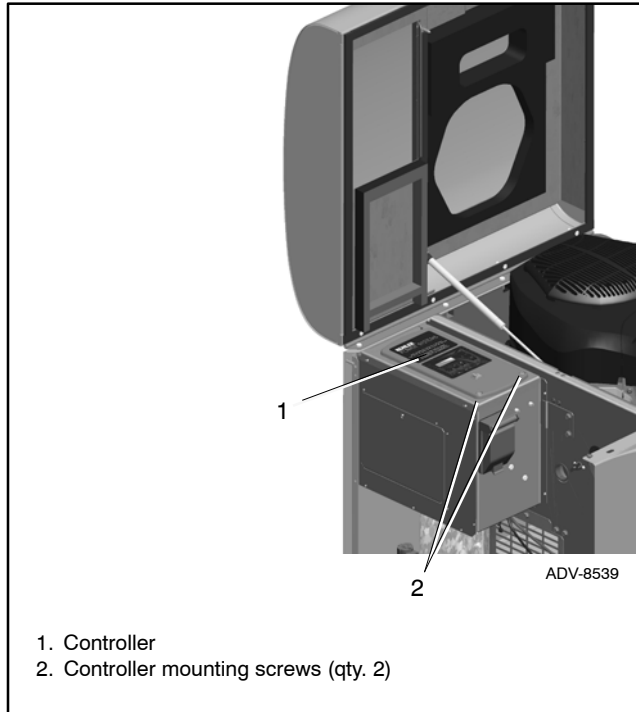

Figure 3-4 Controller Location

3.3.1 Controller Parameters Table

The table on the following pages lists controller parameters that are visible in SiteTech. Parameters marked Read Only are not user-adjustable.

Some parameters that are visible in SiteTech do not apply to all models. Those parameters are marked in the last column, and the line in the table is shaded gray.

Parameters that apply to an optional programmable interface module (PIM), load management device or Model RXT transfer switch are noted in the last column.

The table indicates the following:

- The group in SiteTech that contains the parameter
- Factory default settings
- Units for the setting (e.g. RPM)
- Adjustment range for user-adjustable settings

Note: Some settings are not user-adjustable.

3.3.2 Notes on Selected Parameters

Genset Info

Model numbers and serial numbers are factory-set for each unit. If the controller is replaced, the genset model number and serial number will need to be entered by the installer. For the genset model number, select the appropriate model from the dropdown list. Find the generator set serial number on the nameplate and enter it using SiteTech. See Section 3.5, Controller Replacement, for information about other setup required on a replacement controller.

Changing the genset model number will update the engine model number automatically. Select the genset model number and then click Apply Changes in SiteTech to see the updated engine model number.

Genset Fuel Type

Note: Besides changing the controller setting in SiteTech, the fuel selector valve must be manually set when changing the genset fuel type. See section 5.14 for the fuel conversion procedure.

The Genset Fuel Type setting is located in the Genset System Configuration group in SiteTech. Generator set power and current ratings are different for different fuel types (natural gas or LPG). The fuel type setting is available in SiteTech with controller firmware versions 4.5 and higher.

Changing the Genset Fuel Type setting automatically updates the the Genset Power Rating and Genset Rated Current settings. The power rating is used to determine setpoints for the optional load management device. If a load management device is connected and the generator set is converted to a different fuel, use SiteTech to change the Genset Fuel Type setting.

Genset Voltage Phase Connection

The Genset Voltage Phase Connection setting appears in the Genset System Configuration group in SiteTech. Choose single-phase from the four options in the dropdown list.

Digital Inputs and Outputs

Digital inputs and outputs are available only if the optional Programmable Interface Module (PIM) is connected to the RDC2 or DC2 controller. One PIM provides two digital inputs and 6 digital outputs.

Dropdown menus allow selection of the digital input and output events. Be sure to select Digital Inputs B1–B2 and Digital Outputs B1–B6 in SiteTech. Digital Inputs A1–A2 and Digital Outputs A1–A2 do not apply to the PIM. Digital outputs B7–B12 are reserved for the load management device and cannot be changed by the user. These outputs will display load management device relay status.

Refer to Installation Instruction Sheet TT-1584, provided with the PIM, for information about the input and output events.

RBUS Devices

A maximum of three RBUS devices, including one Model RXT transfer switch, one programmable interface module (PIM), and/or one load management device, can be connected to the generator set. RBUS devices 4 through 5 appear in SiteTech but do not apply to the generator set models covered in this manual at the time of publication.

RBUS devices are numbered according to the device serial numbers, which are read by the RDC2 or DC2 controller. RBUS Device B1 is the RXT transfer switch, PIM, load management device with the lowest serial number. Look at the RBUS device type to determine which device is B1, B2, or B3.

Temperature Settings

In SiteTech, all temperature settings are shown in degrees F but stored as degrees C. When you highlight a parameter value (click it), the °F value changes to the equivalent °C value. Enter temperature settings in °F. The new setting is calculated from a conversion equation, so the final value may include some rounding that makes the setting higher or lower by 1 degree.

Engine Speed Governor Settings

Engine Speed Adjustment. The default setting for the engine speed adjustment is 50. This gives engine speeds of 3600 RPM for 60 Hz models. See Section 5.11.2 for instructions to adjust the engine speed, if necessary.

Note: The system frequency must be set correctly before adjusting the engine speed setting.

Engine Speed Gain Adjustment. The recommended setting for the engine speed gain adjustment is 50, which is the default setting. See Section 5.11.1 for instructions to adjust the Engine Speed Gain, if necessary.

SiteTech Group	Parameter	Units	Adjustment Range *	Default Setting	Notes †
Identity	Vendor		Read Only	Kohler Company	
Identity	Product		Read Only	RDC2	
Identity	Firmware Version		Read Only	N/A	
Engine Metering	Engine Speed	R/min	Read Only	N/A	
Engine Metering	Engine Target Speed	R/min	Read Only	N/A	
Engine Metering	Engine Oil Pressure	kPa	Read Only	N/A	
Engine Metering	Engine Coolant Temperature	°C	Read Only	N/A	
Engine Metering	Battery Voltage	V	Read Only	N/A	
Engine Metering	Lube Oil Temperature	°C	Read Only	N/A	
Engine Metering	Genset Controller Temperature	°C	Read Only	N/A	
Engine Metering	Engine Low Oil Pressure Switch		Read Only	N/A	
Engine Metering	Engine Compartment Temperature	°C	Read Only	N/A	
Engine Speed Governor	Engine Speed Adjustment		0 - 99 See Section 3.3.2.	50	
Engine Speed Governor	Engine Speed Gain Adjustment		No effect.	50	N/A
Generator Metering	Generator Rotation Actual		Read Only	N/A	
Generator Metering	Generator Current Lead/Lag L1		Read Only	N/A	
Generator Metering	Generator Current Lead/Lag L2		Read Only	N/A	
Generator Metering	Generator Current Lead/Lag L3		Read Only	N/A	
Generator Metering	Generator Current Total Lead/Lag		Read Only	N/A	
Generator Metering	Generator Power Factor L1		Read Only	N/A	
Generator Metering	Generator Power Factor L2		Read Only	N/A	
Generator Metering	Generator Power Factor L3		Read Only	N/A	
Generator Metering	Generator Total Power Factor		Read Only	N/A	
Generator Metering	Generator Apparent Power L1	VA	Read Only	N/A	
Generator Metering	Generator Apparent Power L2	VA	Read Only	N/A	
Generator Metering	Generator Apparent Power L3	VA	Read Only	N/A	
Generator Metering	Generator Total Apparent Power	VA	Read Only	N/A	
Generator Metering	Generator Reactive Power L1	VAR	Read Only	N/A	
Generator Metering	Generator Reactive Power L2	VAR	Read Only	N/A	
Generator Metering	Generator Reactive Power L3	VAR	Read Only	N/A	
Generator Metering	Generator Total Reactive Power	VAR	Read Only	N/A	
Generator Metering	Generator True Power L1	W	Read Only	N/A	
Generator Metering	Generator True Power L2	W	Read Only	N/A	
Generator Metering	Generator True Power L3	W	Read Only	N/A	
Generator Metering	Generator True Total Power	W	Read Only	N/A	
Generator Metering	Generator True Percent Of Rated Power	%	Read Only	N/A	
Generator Metering	Generator Voltage L1-L2	V	Read Only	N/A	
Generator Metering	Generator Voltage L2-L3	V	Read Only	N/A	
<p>* Read Only = Not adjustable</p> <p>§ Load management device (LCM, load shed kit, or RXT with combined interface/load management board).</p> <p>† Notes indicate applicability to genset or accessories. N/A = Not applicable to the models covered in this manual.</p> <p>‡ See TT-1584 for more information about digital inputs and outputs.</p> <p>Grayed rows are visible in SiteTech but do not apply to all models.</p>					

SiteTech Group	Parameter	Units	Adjustment Range *	Default Setting	Notes †
Generator Metering	Generator Voltage L3-L1	V	Read Only	N/A	
Generator Metering	Generator Voltage Average Line To Line	V	Read Only	N/A	
Generator Metering	Generator Current L1	A	Read Only	N/A	
Generator Metering	Generator Current L2	A	Read Only	N/A	
Generator Metering	Generator Current L3	A	Read Only	N/A	
Generator Metering	Generator Current Average	A	Read Only	N/A	
Generator Metering	Generator Frequency	Hz	Read Only	N/A	
Genset Info	Genset Model Number Select		8RESV, 10RESV, or 12RESV (Dropdown list)	Factory set per unit. See Section 3.3.2	
Genset Info	Genset Serial Number		0-20 characters		
Genset Info	Alternator Part Number		0-20 characters		N/A
Genset Info	Genset Controller Serial Number		1-10 characters		
Genset Info	Engine Part Number		0-20 characters		N/A
Genset Info	Engine Model Number		SV-620 (8RESV), KT-725-2 (10RESV), KT-725 (12RESV) (Auto select with genset model)		
Genset Info	Engine Serial Number		0-10 characters		N/A
Genset Info	Genset State	N/A	Read Only		
Genset Run Time	Genset Controller Clock Time		Read Only	N/A	
Genset Run Time	Genset Controller Total Operation Time	h	Read Only	N/A	
Genset Run Time	Engine Total Run Time	h	Read Only	N/A	
Genset Run Time	Engine Total Run Time Loaded	h	Read Only	N/A	
Genset Run Time	Engine Total Number Of Starts		Read Only	N/A	
Genset Run Time	Genset Date Time Of Last Maintenance		Read Only (See Section 2.2.5, Resetting the Maintenance Timer)	1/1/01 12:00:00 AM	
Genset Run Time	Engine Run Time Until Maintenance	h	Read Only	200.0	
Genset Run Time	Genset Controller Date Format		MM/DD/YYYY or DD/MM/YYYY	MM/DD/YYYY	
Genset Run Time	Genset Controller Time Format		12 or 24 hr	12 Hr	
Genset Run Time	Genset Date Time of Next Maintenance		Read Only	N/A	
Genset Run Time	Maintenance Period In Days	days	Read Only	365	
Genset Run Time	Maintenance Period Remaining	s	Read Only	31536000	
Genset Run Time	Genset Controller Clock Time Zone Offset		Read Only	1/1/01 12:00:00 AM	
Genset Personality Profile	ECM Model		Auto select with genset model DO NOT CHANGE	No ECM	
Genset Personality Profile	Maximum Alternator Current	A	Read Only	920	

* Read Only = Not adjustable

§ Load management device (LCM, load shed kit, or RXT with combined interface/load management board).

† Notes indicate applicability to genset or accessories. N/A = Not applicable to the models covered in this manual.

‡ See TT-1584 for more information about digital inputs and outputs.

Grayed rows are visible in SiteTech but do not apply to all models.

SiteTech Group	Parameter	Units	Adjustment Range *	Default Setting	Notes †
Genset Personality Profile	Engine Number Of Flywheel Teeth		Locked	1	
Genset Personality Profile	Engine Warmed Up Temperature	°C/F	25 – 60 °C	32°C (90°F)	See note in Section 3.3.2.
Genset Personality Profile	Engine Cooled Down Temperature	°C/F	Locked	79°C (174°F)	
Genset Personality Profile	Engine Crank Disconnect Speed	RPM	300 –1000	1000 (8RESV), 750 (10RESV, 12RESV)	
Genset Personality Profile	Engine Idle Speed	RPM	600 – 3000	2700	
Genset Personality Profile	Engine Run Speed	RPM	1000 – 3900	3600	
Genset Personality Profile	Engine Coolant Temperature Protectives Enabled		No effect.		N/A
Genset Personality Profile	Engine Coolant Temperature Sensor		No effect.		N/A
Genset Personality Profile	Engine High Coolant Temperature Inhibit Delay	s	No effect.		N/A
Genset Personality Profile	Engine Low Coolant Temperature Warning Delay	s	No effect.		N/A
Genset Personality Profile	Engine High Coolant Temperature Warning Delay	s	No effect.		N/A
Genset Personality Profile	Engine Low Coolant Temperature Shutdown Delay	s	No effect.		N/A
Genset Personality Profile	Engine High Coolant Temperature Shutdown Delay	s	No effect.		N/A
Genset Personality Profile	Engine Low Coolant Temperature Warning Limit	°C	No effect.		N/A
Genset Personality Profile	Engine High Coolant Temperature Warning Limit	°C	No effect.		N/A
Genset Personality Profile	Engine High Coolant Temperature Shutdown Limit	°C	No effect.		N/A
Genset Personality Profile	Engine Coolant Temperature Deadband	°C	No effect.		N/A
Genset Personality Profile	Personality Alternator Manufacturer		No effect.		N/A
Genset Personality Profile	Personality Alternator Toc Time Constant	s	No effect.		N/A
Genset Personality Profile	Personality Alternator Number Of Poles		No effect.		N/A
Genset Personality Profile	Personality Alternator Type		No effect.		N/A
Genset Personality Profile	Personality Fixed Voltage 50 Hz	V	No effect.		N/A
Genset Personality Profile	Personality Power Rating Single Phase 50 Hz 10 PF	kW	No effect.		N/A
Genset Personality Profile	Personality Power Rating Single Phase 50 Hz 8 PF	kW	No effect.		N/A
Genset Personality Profile	Personality Power Rating Fixed Volt 50 Hz	kW	No effect.		N/A

* Read Only = Not adjustable

§ Load management device (LCM, load shed kit, or RXT with combined interface/load management board).

† Notes indicate applicability to genset or accessories. N/A = Not applicable to the models covered in this manual.

‡ See TT-1584 for more information about digital inputs and outputs.

Grayed rows are visible in SiteTech but do not apply to all models.

SiteTech Group	Parameter	Units	Adjustment Range *	Default Setting	Notes †
Genset Personality Profile	Personality Power Rating 50 Hz 220 440	kW	No effect.		N/A
Genset Personality Profile	Personality Power Rating 50 Hz 208 415	kW	No effect.		N/A
Genset Personality Profile	Personality Power Rating 50 Hz 200 400	kW	No effect.		N/A
Genset Personality Profile	Personality Power Rating 50 Hz 190 380	kW	No effect.		N/A
Genset Personality Profile	Personality Power Rating 50 Hz 173 346	kW	No effect.		N/A
Genset Personality Profile	Personality Power Rating 50 Hz Delta	kW	No effect.		N/A
Genset Personality Profile	Personality Fixed Voltage 60 Hz	V	No effect.		N/A
Genset Personality Profile	Personality Power Rating Single Phase 60 Hz 10 PF	kW	No effect.		N/A
Genset Personality Profile	Personality Power Rating Single Phase 60 Hz 8 PF	kW	No effect.		N/A
Genset Personality Profile	Personality Power Rating Fixed Volt 60 Hz	kW	No effect.		N/A
Genset Personality Profile	Personality Power Rating 60 Hz 240 480	kW	No effect.		N/A
Genset Personality Profile	Personality Power Rating 60 Hz 230 460	kW	No effect.		N/A
Genset Personality Profile	Personality Power Rating 60 Hz 220 440	kW	No effect.		N/A
Genset Personality Profile	Personality Power Rating 60 Hz 208 416	kW	No effect.		N/A
Genset Personality Profile	Personality Power Rating 60 Hz 190 380	kW	No effect.		N/A
Genset Personality Profile	Personality Power Rating 60 Hz Delta	kW	No effect.		N/A
Genset Personality Profile	Personality Installed Options		Locked	None	N/A
Genset System Configuration	Genset System Voltage	V	110 - 600	240.0	
Genset System Configuration	Genset System Frequency	Hz	50/ 60	60.0	
Genset System Configuration	Genset Voltage Phase Connection		0-3	Single Phase	
Genset System Configuration	Genset Power Rating	kW	10- 5000	7 (8RESV) , 9 (10RESV) , 11 (12RESV)	
Genset System Configuration	Genset Rated Current	A	Read Only	29.2 (8RESV) , 37.5 (10RESV) , 45.8 (12RESV)	
Genset System Configuration	Genset System Battery Voltage	V	12 / 24	12	

* Read Only = Not adjustable

§ Load management device (LCM, load shed kit, or RXT with combined interface/load management board).

† Notes indicate applicability to genset or accessories. N/A = Not applicable to the models covered in this manual.

‡ See TT-1584 for more information about digital inputs and outputs.

Grayed rows are visible in SiteTech but do not apply to all models.

SiteTech Group	Parameter	Units	Adjustment Range *	Default Setting	Notes †
Genset System Configuration	Prime Power Application		Standby or prime	Standby	
Genset System Configuration	Current Transformer Ratio		Locked	400	N/A
Genset System Configuration	Local Start Mode		Read Only	Off	
Genset System Configuration	Measurement System		English or metric	English	
Genset System Configuration	ECM Power		On or Off	Off	
Genset System Configuration	Display Contrast		0 - 100	50	
Genset System Configuration	Genset System Language		0 - 4	English	N/A
Genset System Configuration	Genset Maximum Percent Capacity	%	0 - 120	70.0	
Genset System Configuration	Generator Overloaded Percent	%	0 - 120	85.0	
Genset System Configuration	Under Frequency Shed Level	Hz	0 - 5	0.5	
Genset System Configuration	Base Load Add Time	s	10 - 2400	60	
Genset System Configuration	Base Over Load Shed Time	s	2 - 30	30	
Genset System Configuration	Base Under Frequency Shed Time	s	1 - 20	5	
Genset System Configuration	Genset Fuel Type		Natural Gas or LPG (pulldown)	Natural Gas	
Genset System Configuration	Automatic Start Minimum Voltage	V	15 - 60	51	
Genset System Configuration	Automatic Stop Minimum Percent Load	%	0 - 100	20	
Genset System Configuration	Automatic Start Minimum Voltage Delay	s	1 - 3600	180	
Genset System Configuration	Automatic Stop Minimum Load Delay	s	1 - 3600	180	
Genset System Configuration	ECM Powered Mode		On or Off	Off	
Genset Calibration	Genset Calibration Factor Voltage L1-L2		0.9 - 1.1	0.9803	
Genset Calibration	Genset Calibration Factor Voltage L2-L3		0.9 - 1.1	0.98600	
Genset Calibration	Genset Calibration Factor Voltage L3-L1		0.9 - 1.1	0.9900	
Genset Calibration	Genset Calibration Factor Current L1 - N		0.9 - 1.1	1.000000	
Genset Calibration	Genset Calibration Factor Current L1		0.9 - 1.1	1.04	
Genset Calibration	Genset Calibration Factor Current L2		0.9 - 1.1	1.04	

* Read Only = Not adjustable

§ Load management device (LCM, load shed kit, or RXT with combined interface/load management board).

† Notes indicate applicability to genset or accessories. N/A = Not applicable to the models covered in this manual.

‡ See TT-1584 for more information about digital inputs and outputs.

Grayed rows are visible in SiteTech but do not apply to all models.

SiteTech Group	Parameter	Units	Adjustment Range *	Default Setting	Notes †
Genset Calibration	Genset Calibration Factor Current L3		0.9 - 1.1	1.04	
Genset Calibration	Current Transformer Calibration At No Load		0 - 100	3.5	
Genset Calibration	Current Transformer Calibration At Full Load		0 - 400	121.5	
Advanced Speed Control	Proportional Gain		No effect.		N/A
Advanced Speed Control	Transient Integral Gain		No effect.		N/A
Advanced Speed Control	Derivative Gain		No effect.		N/A
Advanced Speed Control	Slow Correction Integral Gain		No effect.		N/A
Advanced Speed Control	Diagnostic Derivative Gain		No effect.		N/A
Advanced Speed Control	Diagnostic Transient Integral Gain		No effect.		N/A
Voltage Regulator	Voltage Regulator Average Voltage Adjustment	V	108 - 660	240.0 (System voltage)	
Voltage Regulator	Voltage Regulator Volts Per Hertz Slope	%	1 - 10	5	
Voltage Regulator	Voltage Regulator Volts Per Hertz Cut In Frequency	Hz	42 - 62	59	
Voltage Regulator	Voltage Regulator Gain		1 - 255	16	
Engine Timing	Engine Start Delay	s	0 - 300	0	
Engine Timing	Engine Cool Down Delay	s	300 - 600	300	
Engine Timing	Engine Crank On Delay	s	10 - 30	15	
Engine Timing	Engine Crank Pause Delay	s	1 - 60	15	
Engine Timing	Engine Number Of Crank Cycles		1 - 6	3	
Genset Protection	Genset Low Battery Voltage Warning Delay	s	Read Only	90	
Genset Protection	Genset High Battery Voltage Warning Delay	s	Read Only	10	
Genset Protection	Genset Low Battery Voltage Warning Limit	%	80 - 100	100	
Genset Protection	Genset High Battery Voltage Warning Limit	%	110 - 135	125	
Genset Protection	Genset Battery Low Cranking Voltage Warning Delay	s	Read Only	6	
Genset Protection	Genset Battery Low Cranking Voltage Warning Limit	%	Read Only	60	
Engine Protection	Engine Locked Rotor Shutdown Delay	s	1 - 5	3	
Engine Protection	Genset Low Engine Speed Shutdown Limit	%	75 - 95	85	
Engine Protection	Genset High Engine Speed Shutdown Limit	%	No effect.		N/A
Engine Protection	Engine Low Oil Pressure Warning Limit	kPa	No effect.		N/A
Engine Protection	Engine High Oil Pressure Shutdown Limit	kPa	No effect.		N/A

* Read Only = Not adjustable

§ Load management device (LCM, load shed kit, or RXT with combined interface/load management board).

† Notes indicate applicability to genset or accessories. N/A = Not applicable to the models covered in this manual.

‡ See TT-1584 for more information about digital inputs and outputs.

Grayed rows are visible in SiteTech but do not apply to all models.

SiteTech Group	Parameter	Units	Adjustment Range *	Default Setting	Notes †
Generator Protection	Loss Of AC Sensing Shutdown Delay	s	Read Only	3	
Generator Protection	Genset Low Voltage Shutdown Delay	s	Read Only	10	
Generator Protection	Genset High Voltage Shutdown Delay	s	Read Only	2	
Generator Protection	Genset Low Voltage Shutdown Limit	%	Read Only	80	
Generator Protection	Genset High Voltage Shutdown Limit	%	Read Only	120	
Generator Protection	Genset Short Term Low Frequency Shutdown Delay	s	Read Only	10	
Generator Protection	Genset Long Term Low Frequency Shutdown Delay	s	Read Only	60	
Generator Protection	Genset High Frequency Shutdown Delay	s	Read Only	10	
Generator Protection	Genset Low Frequency Shutdown Limit	%	Read Only	90	
Generator Protection	Genset High Frequency Shutdown Limit	%	Read Only	110	
Digital Input A1	Digital Input A1 Value		Read Only	False	N/A
Digital Input A1	Digital Input A1 Enabled		True or False	True	N/A
Digital Input A1	Digital Input A1 Event		See dropdown list in SiteTech. ‡	Fuel Pressure Low Warning	N/A
Digital Input A2	Digital Input A2 Value		Read Only	False	N/A
Digital Input A2	Digital Input A2 Enabled		True or False	True	N/A
Digital Input A2	Digital Input A2 Event		See dropdown list in SiteTech. ‡	Auxiliary Input Warning	N/A
Digital Input B1	Digital Input B1 Value		Read Only	False	PIM
Digital Input B1	Digital Input B1 Enabled		True or False	False	PIM
Digital Input B1	Digital Input B1 Event		See dropdown list in SiteTech. ‡	None (0)	PIM
Digital Input B2	Digital Input B2 Value		Read Only	False	PIM
Digital Input B2	Digital Input B2 Enabled		True or False	False	PIM
Digital Input B2	Digital Input B2 Event		See dropdown list in SiteTech. ‡	None (0)	PIM
Digital Output A1	Digital Output A1 Value		Read Only	False	N/A
Digital Output A1	Digital Output A1 Event		See dropdown list in SiteTech. ‡	NFPA 110 Alarm Active	N/A
Digital Output A2	Digital Output A2 Value		Read Only	N/A	N/A
Digital Output A2	Digital Output A2 Event		See dropdown list in SiteTech. ‡	N/A	N/A
Digital Output B1	Digital Output B1 Value		Read Only	False	PIM
Digital Output B1	Digital Output B1 Event		See dropdown list in SiteTech. ‡	Generator Running	PIM
Digital Output B2	Digital Output B2 Value		Read Only	False	PIM

* Read Only = Not adjustable
§ Load management device (LCM, load shed kit, or RXT with combined interface/load management board).
† Notes indicate applicability to genset or accessories. N/A = Not applicable to the models covered in this manual.
‡ See TT-1584 for more information about digital inputs and outputs.
Grayed rows are visible in SiteTech but do not apply to all models.

SiteTech Group	Parameter	Units	Adjustment Range *	Default Setting	Notes †
Digital Output B2	Digital Output B2 Event		See dropdown list in SiteTech. ‡	Common Fault	PIM
Digital Output B3	Digital Output B3 Value		Read Only	False	PIM
Digital Output B3	Digital Output B3 Event		See dropdown list in SiteTech. ‡	Battery Voltage Low Warning	PIM
Digital Output B4	Digital Output B4 Value		Read Only	False	PIM
Digital Output B4	Digital Output B4 Event		See dropdown list in SiteTech. ‡	Not In Auto Warning	PIM
Digital Output B5	Digital Output B5 Value		Read Only	False	PIM
Digital Output B5	Digital Output B5 Event		See dropdown list in SiteTech. ‡	Engine Cool Down Active	PIM
Digital Output B6	Digital Output B6 Value		Read Only	False	PIM
Digital Output B6	Digital Output B6 Event		See dropdown list in SiteTech. ‡	Normal Power Source Unavailable	PIM
Digital Output B7	Digital Output B7 Value		Read Only	False	Load Mgmt§
Digital Output B7	Digital Output B7 Event		Read Only	65004	Load Mgmt§
Digital Output B8	Digital Output B8 Value		Read Only	False	Load Mgmt§
Digital Output B8	Digital Output B8 Event		Read Only	65007	Load Mgmt§
Digital Output B9	Digital Output B9 Value		Read Only	False	Load Mgmt§
Digital Output B9	Digital Output B9 Event		Read Only	65003	Load Mgmt§
Digital Output B10	Digital Output B10 Value		Read Only	False	Load Mgmt§
Digital Output B10	Digital Output B10 Event		Read Only	65005	Load Mgmt§
Digital Output B11	Digital Output B11 Value		Read Only	False	Load Mgmt§
Digital Output B11	Digital Output B11 Event		Read Only	65006	Load Mgmt§
Digital Output B12	Digital Output B12 Value		Read Only	False	Load Mgmt§
Digital Output B12	Digital Output B12 Event		Read Only	65008	Load Mgmt§
ATS Metering Summary	ATS Contactor Position		Read Only	N/A	RXT
ATS Metering Summary	ATS Sources Available		Read Only	N/A	RXT
Source 1 Metering	Source 1 Rotation Actual		Read Only	N/A	RXT
Source 1 Metering	Source 1 Voltage L1-L2	V	Read Only	N/A	RXT
Source 1 Metering	Source 1 Voltage L2-L3	V	Read Only	N/A	RXT
Source 1 Metering	Source 1 Voltage L3-L1	V	Read Only	N/A	RXT
Source 1 Metering	Source 1 Voltage Average Line To Line	V	Read Only	N/A	RXT
Source 1 Metering	Source 1 Frequency	Hz	Read Only	N/A	RXT
<p>* Read Only = Not adjustable</p> <p>§ Load management device (LCM, load shed kit, or RXT with combined interface/load management board).</p> <p>† Notes indicate applicability to genset or accessories. N/A = Not applicable to the models covered in this manual.</p> <p>‡ See TT-1584 for more information about digital inputs and outputs.</p> <p>Grayed rows are visible in SiteTech but do not apply to all models.</p>					

SiteTech Group	Parameter	Units	Adjustment Range *	Default Setting	Notes †
Source 2 Metering	Source 2 Rotation Actual		Read Only	N/A	RXT
Source 2 Metering	Source 2 Voltage L1-L2	V	Read Only	N/A	RXT
Source 2 Metering	Source 2 Voltage L2-L3	V	Read Only	N/A	RXT
Source 2 Metering	Source 2 Voltage L3-L1	V	Read Only	N/A	RXT
Source 2 Metering	Source 2 Voltage Average Line To Line	V	Read Only	N/A	RXT
Source 2 Metering	Source 2 Frequency	Hz	Read Only	N/A	RXT
ATS Connection Configuration	ATS Source		Read Only	N/A	RXT
Source 1 System Configuration	Source 1 System Voltage	V	110.0 - 600.0	Genset System Voltage	RXT
Source 1 System Configuration	Source 1 System Frequency	Hz	48.0 - 62.0	Genset System Frequency	RXT
Source 1 System Configuration	Source 1 Voltage Debounce Delay	s	1 - 99	0.5	RXT
Source 1 System Configuration	Source 1 Low Voltage Pickup	%	85 - 100	90	RXT
Source 1 System Configuration	Source 1 Low Voltage Dropout	%	75 - 98	90	RXT
Source 1 Calibration	Source 1 Calibration Factor Voltage L1-L2		Read Only	1	RXT
Source 1 Calibration	Source 1 Calibration Factor Voltage L2-L3		Read Only	1	RXT
Source 1 Calibration	Source 1 Calibration Factor Voltage L3-L1		Read Only	1	RXT
Source 2 System Configuration	Source 2 System Voltage	V	110.0 - 600.0	240.0	RXT
Source 2 System Configuration	Source 2 System Frequency	Hz	48.0 - 62.0	60.0	RXT
Source 2 System Configuration	Source 2 Voltage Debounce Delay	s	0.1 - 9.9	0.5	RXT
Source 2 System Configuration	Source 2 Low Voltage Pickup	%	85 - 100	90	RXT
Source 2 System Configuration	Source 2 Low Voltage Dropout	%	75 - 98	90	RXT
Source 2 Calibration	Source 2 Calibration Factor Voltage L1-L2		Read Only	1	RXT
Source 2 Calibration	Source 2 Calibration Factor Voltage L2-L3		Read Only	1	RXT
Source 2 Calibration	Source 2 Calibration Factor Voltage L3-L1		Read Only	1	RXT
ATS Exercise	Exercise Interval		Weekly or Every Other Week	Weekly	RXT
ATS Exercise	Exercise Run Duration	min	10 - 30	20	RXT
ATS Exercise	Exercise Mode		Pulldown See List	Unloaded Cycle (2)	RXT
ATS Exercise	Exercise Warning Enabled		True or False	True	RXT
<p>* Read Only = Not adjustable § Load management device (LCM, load shed kit, or RXT with combined interface/load management board). † Notes indicate applicability to genset or accessories. N/A = Not applicable to the models covered in this manual. ‡ See TT-1584 for more information about digital inputs and outputs. Grayed rows are visible in SiteTech but do not apply to all models.</p>					

SiteTech Group	Parameter	Units	Adjustment Range *	Default Setting	Notes †
ATS Delays	ATS Transfer From Preferred Delay	s	1 - 10	3	RXT
ATS Delays	ATS Transfer From Standby Delay	s	1 - 600	120	RXT
ATS Delays	ATS Source 2 Engine Start Delay	s	1 - 10	3	RXT
Modbus	Is Modbus Master		0 - 1	0	
Network Configuration	DHCP Enabled		True or False	True	OnCue Plus
Network Configuration	Static IP Address		0.0.0.0 - 255.255.255.255	0.0.0.0	OnCue Plus
Network Configuration	Static Subnet Mask		0.0.0.0 - 255.255.255.255	0.0.0.0	OnCue Plus
Network Configuration	Static Default Gateway		0.0.0.0 - 255.255.255.255	0.0.0.0	OnCue Plus
Network Configuration	Static DNS Server 1		0.0.0.0 - 255.255.255.255	0.0.0.0	OnCue Plus
Network Configuration	Static DNS Server 2		0.0.0.0 - 255.255.255.255	0.0.0.0	OnCue Plus
Network Configuration	Server Host Name		devices.kohler.com	devices.kohler.com	OnCue Plus
Network Status	IP Address		Read Only	0.0.0.0	OnCue Plus
Network Status	Subnet Mask		Read Only	0.0.0.0	OnCue Plus
Network Status	Default Gateway		Read Only	0.0.0.0	OnCue Plus
Network Status	DNS Server 1		Read Only	0.0.0.0	OnCue Plus
Network Status	DNS Server 2		Read Only	0.0.0.0	OnCue Plus
Network Status	MAC Address		Read Only	N/A	OnCue Plus
Network Status	Connected Server IP Address		Read Only	0.0.0.0	OnCue Plus
Network Status	Network Connection Established		Read Only	False	OnCue Plus
Network Status	Media Connected		Read Only	False	OnCue Plus
RBUS Network	RBUS Active		Read Only	False	
RBUS Network	RBUS Connection Count		Read Only	0	
RBUS Network	RBUS Net Cycle Time	ms	Read Only	100	
RBUS Network	RBUS Timeouts		Read Only	0	
RBUS Network	RBUS Errors		Read Only	0	
<p>* Read Only = Not adjustable § Load management device (LCM, load shed kit, or RXT with combined interface/load management board). † Notes indicate applicability to genset or accessories. N/A = Not applicable to the models covered in this manual. ‡ See TT-1584 for more information about digital inputs and outputs. Grayed rows are visible in SiteTech but do not apply to all models.</p>					

SiteTech Group	Parameter	Units	Adjustment Range *	Default Setting	Notes †
RBUS Devices B1	RBUS Devices B1 Serial Number		Read Only	N/A	RXT, PIM, or Load Mgmt§
RBUS Devices B1	RBUS Devices B1 Type		Read Only (RXT, PIM, or Load Mgmt§)	N/A	
RBUS Devices B1	RBUS Devices B1 Communication Errors		Read Only	N/A	
RBUS Devices B1	RBUS Devices B1 Communication Timeouts		Read Only	N/A	
RBUS Devices B1	RBUS Devices B1 Modbus Id		Read Only	N/A	
RBUS Devices B1	RBUS Devices B1 Last Connection Date		Read Only	N/A	
RBUS Devices B1	RBUS Devices B1 Firmware Version		Read Only	N/A	
RBUS Devices B1	RBUS Devices B1 Connected		Read Only	N/A	
RBUS Devices B2	RBUS Devices B2 Type		Read Only (RXT, PIM, or Load Mgmt§)	N/A	
RBUS Devices B2	RBUS Devices B2 Communication Errors		Read Only	N/A	
RBUS Devices B2	RBUS Devices B2 Communication Timeouts		Read Only	N/A	
RBUS Devices B2	RBUS Devices B2 Modbus Id		Read Only	N/A	
RBUS Devices B2	RBUS Devices B2 Last Connection Date		Read Only	N/A	
RBUS Devices B2	RBUS Devices B2 Firmware Version		Read Only	N/A	
RBUS Devices B2	RBUS Devices B2 Connected		Read Only	N/A	
RBUS Devices B3	RBUS Devices B3 Serial Number		Read Only	N/A	RXT, PIM, or Load Mgmt§
RBUS Devices B3	RBUS Devices B3 Type		Read Only (RXT, PIM, or Load Mgmt§)	N/A	
RBUS Devices B3	RBUS Devices B3 Communication Errors		Read Only	N/A	
RBUS Devices B3	RBUS Devices B3 Communication Timeouts		Read Only	N/A	
RBUS Devices B3	RBUS Devices B3 Modbus Id		Read Only	N/A	
RBUS Devices B3	RBUS Devices B3 Last Connection Date		Read Only	N/A	
RBUS Devices B3	RBUS Devices B3 Firmware Version		Read Only	N/A	
RBUS Devices B3	RBUS Devices B3 Connected		Read Only	N/A	
RBUS Devices B4	RBUS Devices B4 Serial Number		Read Only	N/A	
RBUS Devices B4	RBUS Devices B4 Type		Read Only	N/A	N/A
RBUS Devices B4	RBUS Devices B4 Communication Errors		Read Only	N/A	N/A
RBUS Devices B4	RBUS Devices B4 Communication Timeouts		Read Only	N/A	N/A
RBUS Devices B4	RBUS Devices B4 Modbus Id		Read Only	N/A	N/A

* Read Only = Not adjustable

§ Load management device (LCM, load shed kit, or RXT with combined interface/load management board).

† Notes indicate applicability to genset or accessories. N/A = Not applicable to the models covered in this manual.

‡ See TT-1584 for more information about digital inputs and outputs.

Grayed rows are visible in SiteTech but do not apply to all models.

SiteTech Group	Parameter	Units	Adjustment Range *	Default Setting	Notes †
RBUS Devices B4	RBUS Devices B4 Last Connection Date		Read Only	N/A	N/A
RBUS Devices B4	RBUS Devices B4 Firmware Version		Read Only	N/A	N/A
RBUS Devices B4	RBUS Devices B4 Connected		Read Only	N/A	N/A
RBUS Devices B5	RBUS Devices B5 Serial Number		Read Only	N/A	N/A
RBUS Devices B5	RBUS Devices B5 Type		Read Only	N/A	N/A
RBUS Devices B5	RBUS Devices B5 Communication Errors		Read Only	N/A	N/A
RBUS Devices B5	RBUS Devices B5 Communication Timeouts		Read Only	N/A	N/A
RBUS Devices B5	RBUS Devices B5 Modbus Id		Read Only	N/A	N/A
RBUS Devices B5	RBUS Devices B5 Last Connection Date		Read Only	N/A	N/A
RBUS Devices B5	RBUS Devices B5 Firmware Version		Read Only	N/A	N/A
RBUS Devices B5	RBUS Devices B5 Connected		Read Only	N/A	N/A
<p>* Read Only = Not adjustable</p> <p>§ Load management device (LCM, load shed kit, or RXT with combined interface/load management board).</p> <p>† Notes indicate applicability to genset or accessories. N/A = Not applicable to the models covered in this manual.</p> <p>‡ See TT-1584 for more information about digital inputs and outputs.</p> <p>Grayed rows are visible in SiteTech but do not apply to all models.</p>					

3.4 Controller Firmware

The manufacturer may release new versions of controller firmware. Kohler® distributors can download the latest software from the Kohler Power Resource Center website. Controller firmware is also available for download on the Kohler dealer portal or at www.kohlergenerators.com/usb.

A personal computer (laptop), a USB cable, and Kohler® SiteTech™ or USB Utility are required for firmware updates (updating controller firmware is not available with OnCue Plus). Use a USB cable to connect the computer to the controller's USB port. See Section 3.2 for USB connection information.

The firmware version number is shown in the controller's Overview menu. See SW Version in Figure 3-5. The firmware version number is also displayed in SiteTech™ and OnCue® Plus software under parameters. In SiteTech, the firmware version number is shown in the Identity Group, which is the first group displayed. Refer to the SiteTech™, OnCue® Plus, or USB Utility software manuals for specific instructions.

Firmware version numbers: Preceding zeroes may be dropped from firmware version numbers. For example, version number 4.03 is the same as version 4.3. The version number displayed in SiteTech or OnCue® Plus may show a third number. For example, SiteTech may display version 4.3.5 for software version 4.3.

For instructions about loading new firmware onto the controller, refer to the SiteTech Software Operation Manual or the USB Utility Instructions.

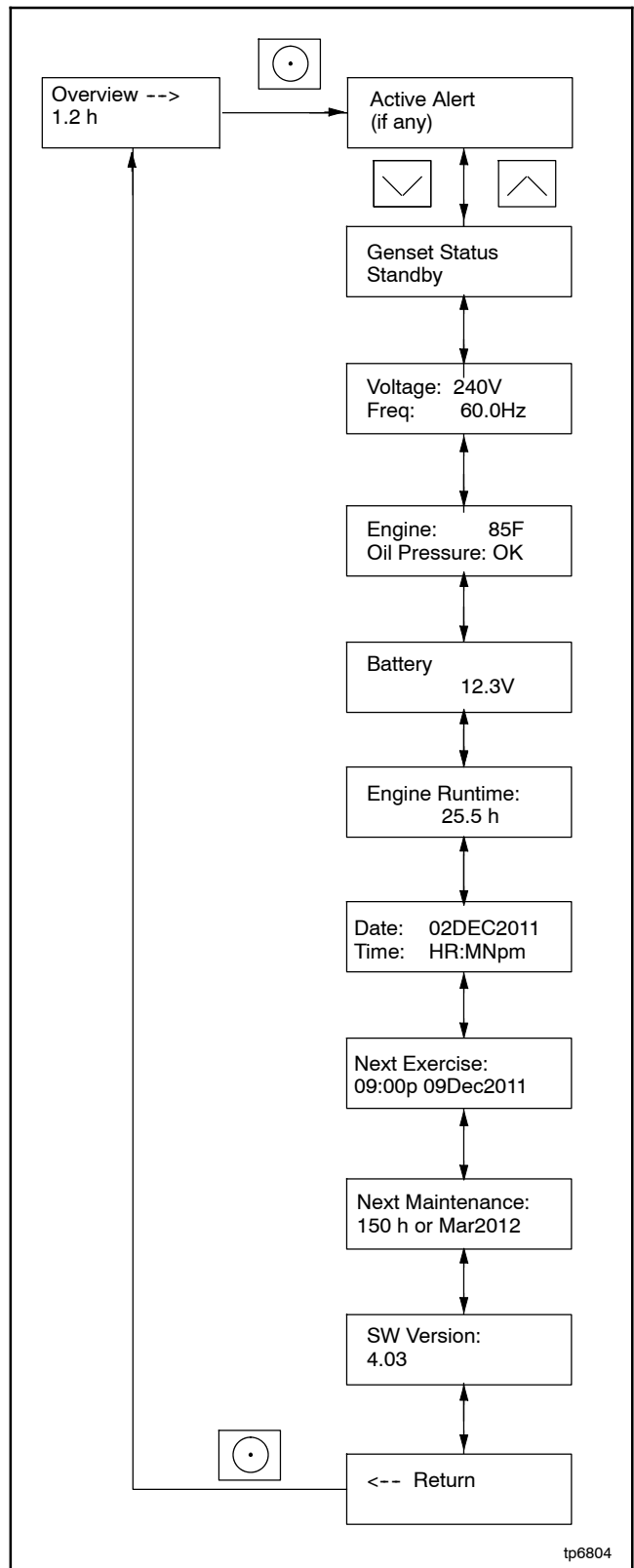
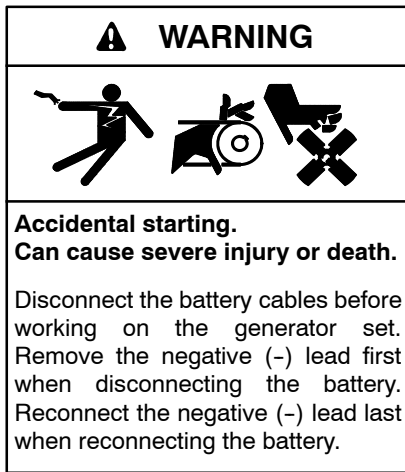

Figure 3-5 SW Version Number in Overview Menu

3.5 Controller Replacement



Disabling the generator set. Accidental starting can cause severe injury or death. Before working on the generator set or equipment connected to the set, disable the generator set as follows: (1) Press the generator set off/reset button to shut down the generator set. (2) Disconnect the power to the battery charger, if equipped. (3) Remove the battery cables, negative (-) lead first. Reconnect the negative (-) lead last when reconnecting the battery. Follow these precautions to prevent the starting of the generator set by the remote start/stop switch.

If the troubleshooting procedures in Section 4 identify a failed controller, use the procedure in this section for controller replacement. Always check the controller settings, wiring, and connections before replacing the controller.

Some setup is required after the new controller is installed. There are several ways to set up the controller:

- The controller can be set up using the buttons on the RDC2 or DC2 controller.
- The controller can be set up using a personal computer and Kohler® SiteTech™ software.
- If a controller settings file was created at installation or at some other time when the controller was known to be operating correctly, a personal computer (laptop) with Kohler SiteTech software can be used to load the settings onto the new controller.

Note: Load the old controller settings onto the new controller only if you are certain that the settings are correct. Many controller operation problems can be caused by incorrect settings.

In some cases, the Kohler Generator Service Department may provide a settings file to load onto the controller for testing or troubleshooting. See TP-6701, SiteTech Software Operation Manual, for instructions to export and import settings after controller replacement.

3.5.1 Controller Replacement Procedure

1. Using the enclosure locking tool provided with the generator set, open the enclosure roof. See Figure 3-6.
2. Press the OFF button on the controller.
3. Disconnect utility power to the generator set by opening the circuit breaker in the distribution panel. Use a voltmeter to verify that utility power has been disconnected. See Figure 3-7 for the utility power connection location.
4. Disconnect the generator set engine starting battery, negative (-) lead first.
5. Remove the two (2) screws securing the controller to the junction box and *carefully* lift the bottom edge of the controller. See Figure 3-6.

Note: Be careful of the leads and harness connected to the controller panel.

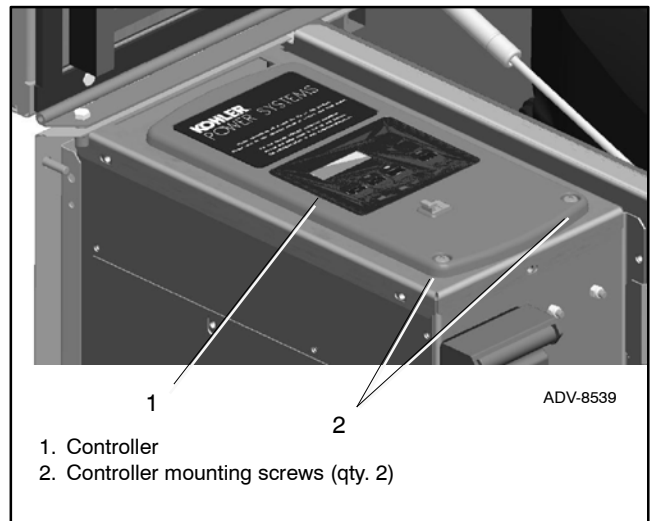

Figure 3-6 Controller Location

6. Note the connections on the back of the controller, and then disconnect all harnesses and leads from the controller. See Figure 3-8 or the wiring diagram.
7. Remove the old controller.
8. Reconnect all harnesses to the new controller assembly.
9. Install the controller onto the junction box using the two (2) screws removed in step 5.
10. Reconnect the engine starting battery, negative (-) lead last.
11. Reconnect the utility power to the generator set by closing the circuit breaker in the distribution panel.
12. The controller will prompt you to set the date and time, and then to set the exerciser. See the generator set Operation Manual for instructions, if necessary.
13. Check the firmware version on the controller, and update to the latest released version, if necessary. See Section 3.4 and TP-6701, SiteTech Software Operation Manual, for instructions.
14. Set up the controller as instructed in Section 3.6, Controller Setup.
15. Calibrate the voltage. See Section 3.7, Voltage Calibration.
16. If OnCue® Plus is used to monitor this generator set, reset the OnCue password on the controller and note the new password. See Section 3.8, Setting the OnCue Plus Password. Then connect with OnCue Plus and enter the new password.
17. Verify that OnCue® Plus can communicate with the generator set over the Internet before leaving the job site.

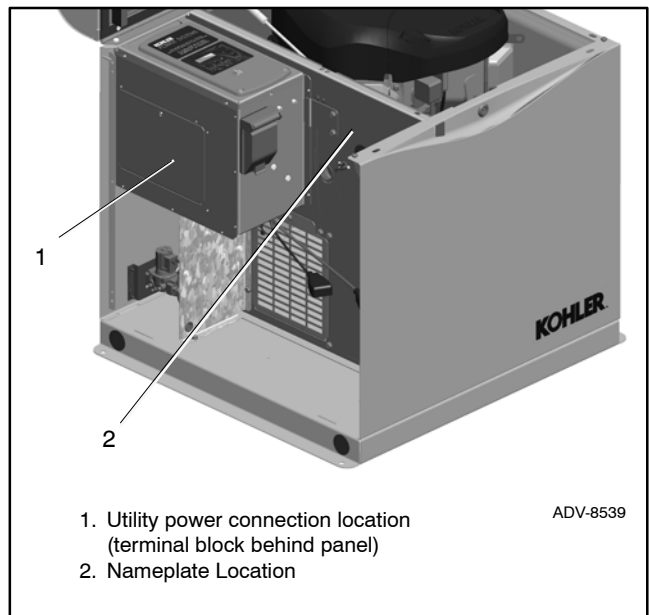

Figure 3-7 Utility Power Connection and Nameplate Locations

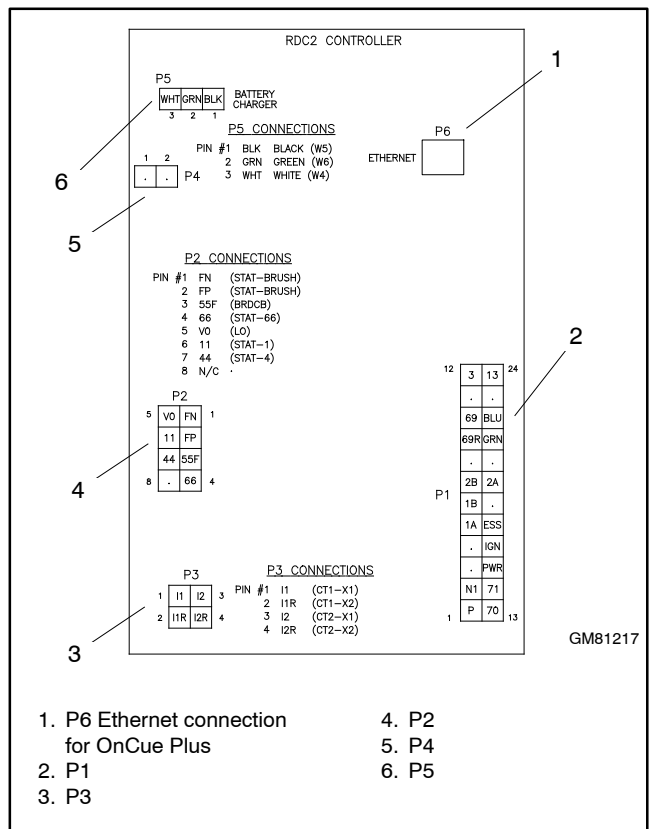

Figure 3-8 Controller Connections

3.6 Controller Setup

Controller setup is required after installation. Follow the instructions in this section to set the necessary parameters.

If a personal computer (laptop) and Kohler® SiteTech™ software were used to create a controller settings file at the time of generator set installation (when the controller was known to be operating correctly), then SiteTech software can be used to load the saved settings onto the new controller. See TP-6701, SiteTech Software Operation Manual, for instructions to export and import controller settings.

Note: Load the old controller settings to the new controller only if you are certain that the settings are correct. Many generator set operation problems can be caused by incorrect settings.

Controller Setup Notes:

- Some of the required information can be found on the generator set nameplate. See Figure 3-7 for the nameplate location.
- Genset Model Number: For the 8RESVL, select Model 8RESV. For 10RESVL, select 10RESV. For 12RESVL, select 12RESV.
- The Fuel Type parameter is available with controller firmware versions 4.5 or higher. The fuel type setting affects the generator set power rating, which is used to determine setpoints for the optional load management device. Setting the Fuel Type is recommended if the generator set is connected to a load management device.

Controller Setup Procedure

1. Use one of the following methods to set the parameters shown in Figure 3-9.
 - a. The RDC2 controller can be set up using the buttons on the controller to navigate through the controller menus and change the settings. See the required controller menus in Figure 3-10 and Figure 3-11. See the generator set operation manual for additional instructions, if necessary.
 - b. The RDC2 and DC2 can be set up using a personal computer and Kohler® SiteTech™ software.
2. Check the voltage calibration and adjust, if necessary. See Section 3.7, Voltage Calibration.
3. If OnCue® Plus is used to monitor this generator set, reset the OnCue password on the controller and note the new password. See Section 3.8, Setting the OnCue Plus Password. Then connect with OnCue Plus and enter the new password.
4. Verify that OnCue® Plus can communicate with the generator set over the Internet before leaving the job site.

Parameter	Controller Menu	SiteTech Group	Settings, 8/10/12RESV(L)
Genset Model Number	Genset Information	Genset Info	8RESV*, 10RESV*, or 12RESV*
Genset Serial Number			From nameplate; see Figure 3-7.
Fuel Type †	Genset System	Genset System Configuration	Natural Gas or Liquid Propane (LPG)
Phase Connection			Single Phase
Genset System Voltage			From nameplate; see Figure 3-7.
Genset System Frequency			60 Hz
* For 8RESVL, select 8RESV. For 10RESVL, select 10RESV, For 12RESVL, select 12RESV.			
† Fuel Type is available with controller firmware versions 4.5 or higher.			

Figure 3-9 Controller Setup

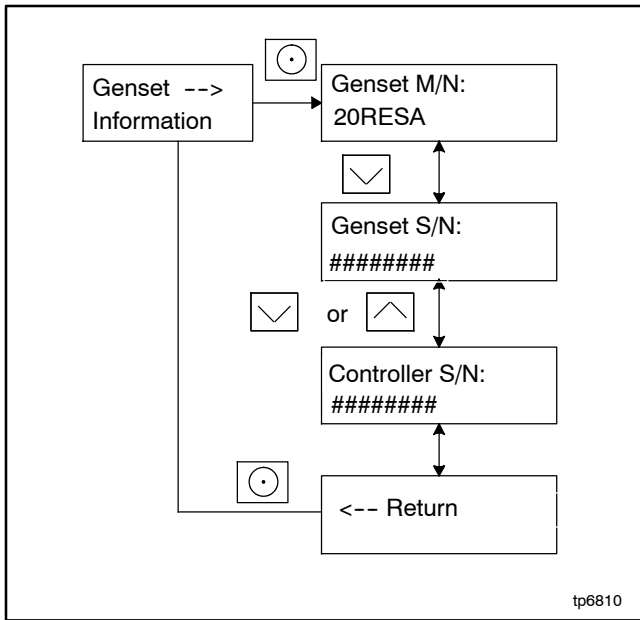
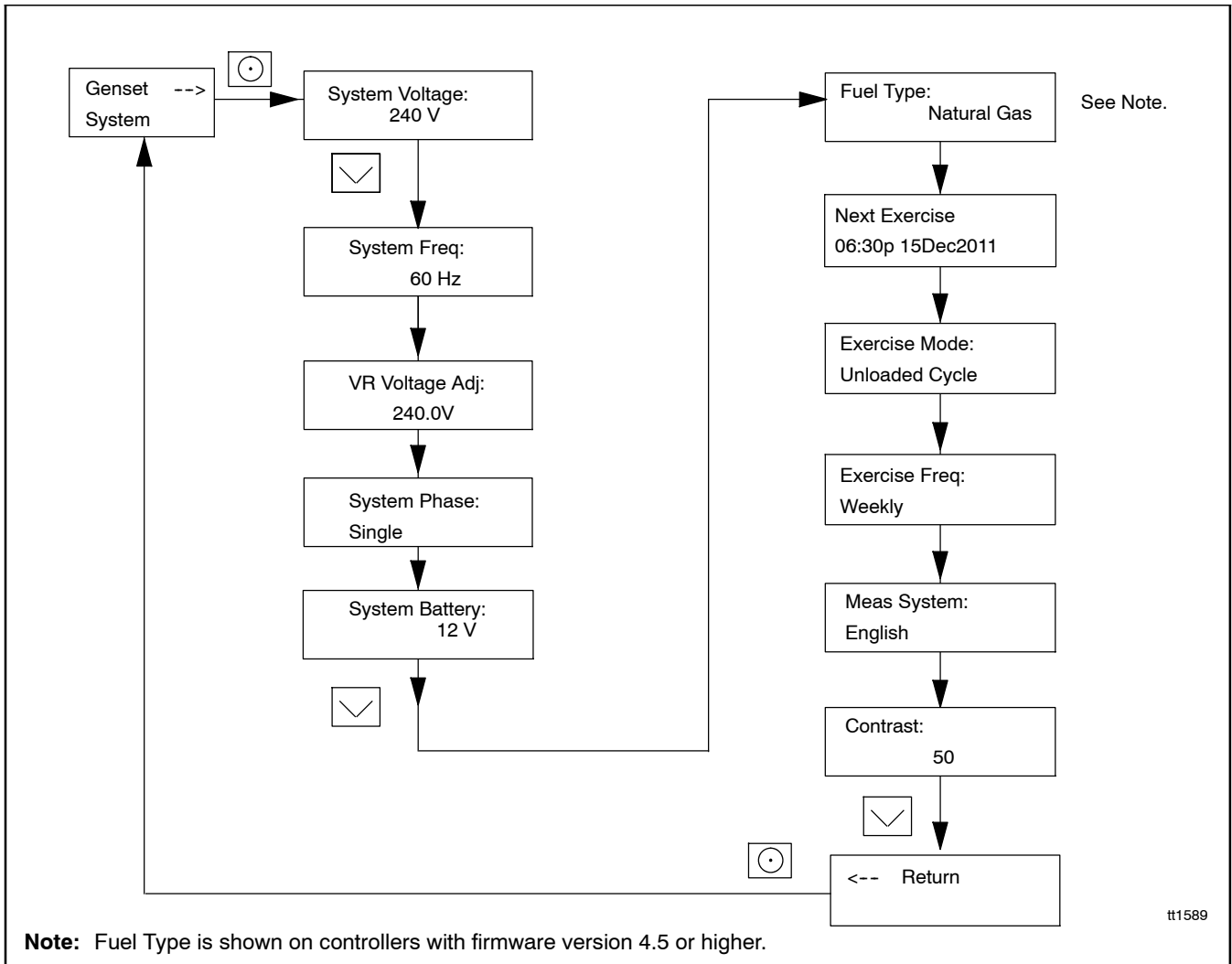

Figure 3-10 Generator Set Information Menu, RDC2



Note: Fuel Type is shown on controllers with firmware version 4.5 or higher.

Figure 3-11 Genset System Menu, RDC2

Parameter	123456
^ Genset Info	
Genset Model Number Select	8RESV
Genset Serial Number	123456
Alternator Part Number	
Genset Controller Serial Number	0
Engine Part Number	
Engine Model Number	SV-620
Engine Serial Number	
Genset State	Standby
^ Genset Run Time	
^ Genset Personality Profile	
^ Genset System Configuration	
Genset System Voltage	240.0 V
Genset System Frequency	60.0 Hz
Genset Voltage Phase Connection	Single Phase
Genset Power Rating	8.0 kW
Genset Rated Current	33.3 A
Genset System Battery Voltage	12 V
Prime Power Application	Standby
Current Transformer Ratio	400
Local Start Mode	Off
Measurement System	English
ECM Power	Off
Display Contrast	50
Genset System Language	English
Genset Maximum Percent Capacity	70.0 %
Generator Overloaded Percent	85.0 %
Under Frequency Shed Level	0.50 Hz
Base Load Add Time	60.0 s
Base Over Load Shed Time	30.0 s
Base Under Frequency Shed Time	5.0 s
Genset Fuel Type	Natural Gas
Automatic Start Minimum Voltage	51.0 V
Automatic Stop Minimum Percent Load	20.0 %
Automatic Start Minimum Voltage Delay	180.0 s
Automatic Stop Minimum Load Delay	180.0 s
ECM Powered Mode	Off
^ Genset Calibration	

1. Genset model and serial numbers

2. System settings

3. Fuel type (controller firmware version 3.5 or higher)

tt6907

Figure 3-12 Controller Setup Using SiteTech™

3.7 Voltage Calibration

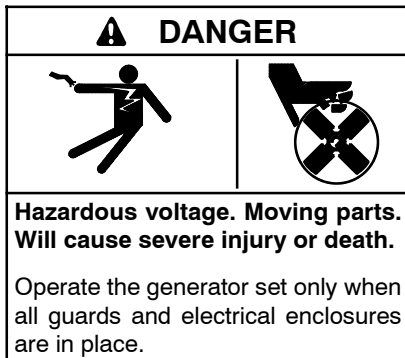

Testing live electrical circuits. Hazardous voltage or current will cause severe injury or death. Have trained and qualified personnel take diagnostic measurements of live circuits. Use adequately rated test equipment with electrically insulated probes and follow the instructions of the test equipment manufacturer when performing voltage tests. Observe the following precautions when performing voltage tests: (1) Remove all jewelry. (2) Stand on a dry, approved electrically insulated mat. (3) Do not touch the enclosure or components inside the enclosure. (4) Be prepared for the system to operate automatically. (600 volts and under)

Servicing the generator set when it is operating. Exposed moving parts will cause severe injury or death. Keep hands, feet, hair, clothing, and test leads away from the belts and pulleys when the generator set is running. Replace guards, screens, and covers before operating the generator set.

Short circuits. Hazardous voltage/current will cause severe injury or death. Short circuits can cause bodily injury and/or equipment damage. Do not contact electrical connections with tools or jewelry while making adjustments or repairs. Remove all jewelry before servicing the equipment.

Correct voltage calibration is necessary for proper generator set operation. Check the voltage calibration after controller replacement or generator set reconnection, and adjust if necessary.

The RDC2 controller can be calibrated using the controller keypad and menus, or using a personal computer with Kohler® SiteTech™ software. SiteTech is required for calibration of the DC2 controller.

3.7.1 Calibration using the RDC2 Controller Keypad and Menu

The controller's voltage calibration can be adjusted using the controller keypad. See Figure 3-13 and follow the procedure below.

Note: A digital voltmeter is required for these adjustments.

1. With the generator set off, connect a digital multimeter to measure output voltage across L1 and L2. Set the meter to measure AC volts.
2. Start the generator set by pressing the RUN button on the RDC2 controller.
3. On the RDC2 controller, press the Select button and then use the arrow buttons to navigate to the Generator Metering menu on the RDC2 controller.
4. Press the Select button to display Volts L1-L2. Compare the number displayed with the voltmeter reading.
5. If the correct voltage is not displayed, follow these steps to adjust it:
 - a. Press the Select button. The voltage will flash.
 - b. Press the up or down arrow button to adjust the voltage to match the voltmeter reading.
 - c. Press Select to save the voltage setting. The voltage stops flashing.
 - d. Wait for the voltmeter reading to stabilize. This may take 30 to 60 seconds.
6. Use the arrow buttons to step down to the Return screen. Press Select to exit the Generator Metering menu.

Note: Pressing select when Reset Calibration is displayed will discard the changes and reset the calibration to the original readings.

7. Press OFF to stop the generator set.

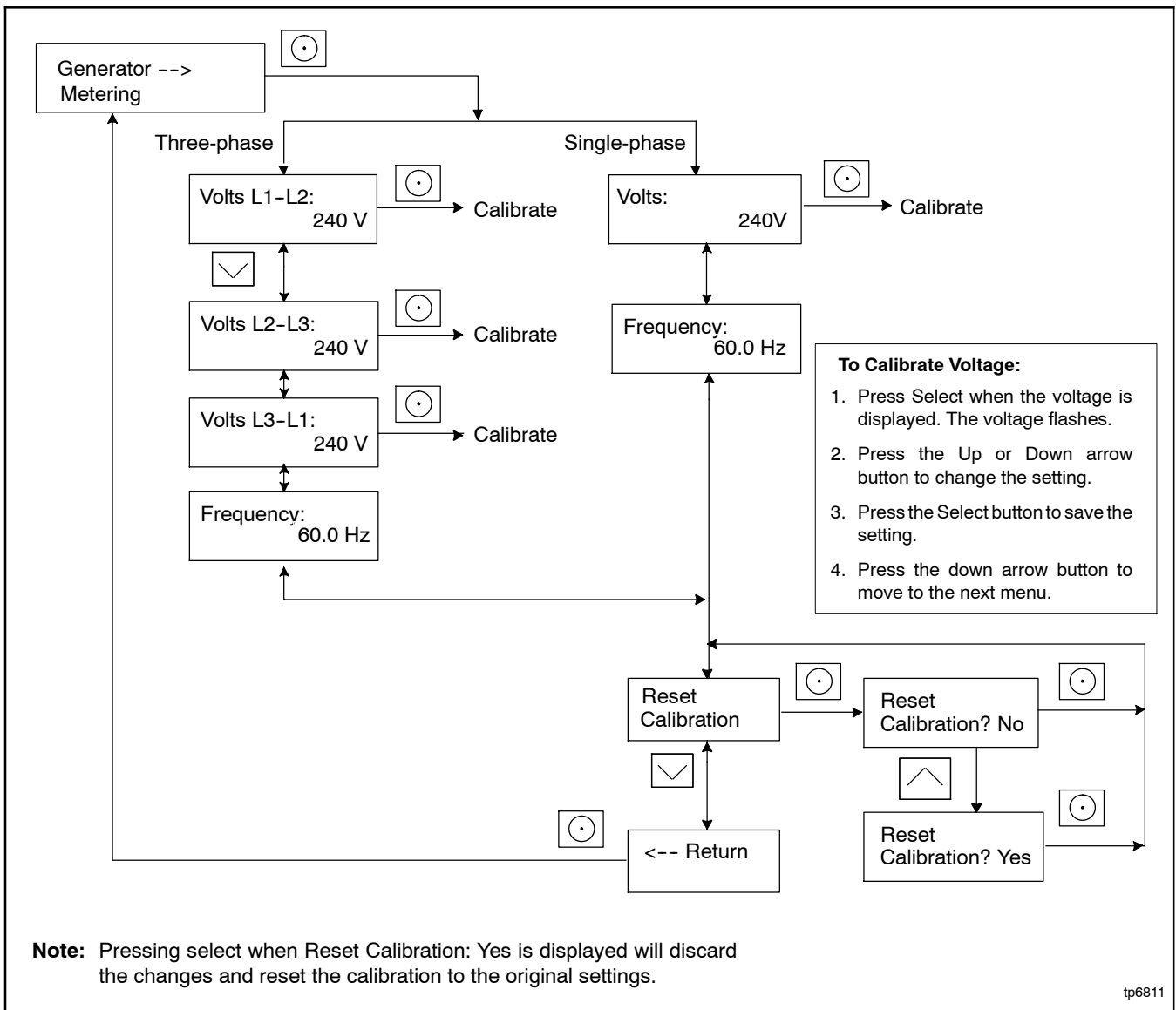

Figure 3-13 Voltage Calibration

3.7.2 Calibration Using SiteTech

Voltage calibration factors can be adjusted using SiteTech software to calibrate the RDC2 or DC2 controller. Connect a personal computer (laptop) to the controller using a USB cable and follow this procedure to use Kohler® SiteTech™ software to calibrate the controller.

The voltage calibration factors are located in the Genset Calibration group in SiteTech™. Find the parameter labelled Genset Calibration Factor Voltage, L1-L2. See Figure 3-15.

Note: A digital voltmeter is required for these adjustments.

1. With the generator set off, connect a digital multimeter to measure output voltage across L1 and L2. Set the meter to measure AC volts.
2. Start the generator set by pressing the RUN button on the RDC2 controller.
3. Compare the voltage reading on the digital voltmeter to the voltage displayed by the controller.

Note: On the DC2 controller, the voltage is shown in the scrolling status displays when the generator set is running. Generator Voltage L1-L2 is also displayed in SiteTech in the Generator Metering group.

4. If the voltage displayed on the controller does not match the measured voltage, use the equation in Figure 3-14 to calculate a new value for Genset Calibration Factor Voltage, L1-L2.
5. Type the new value for Genset Calibration Factor Voltage, L1-L2 into SiteTech and click on Apply Changes. See Figure 3-15.
6. Allow a few seconds for the controller to adjust to the new factor and then compare the voltmeter reading with the voltage displayed on the controller.
7. If the voltage readings do not match, check your calculations. Check the calibration factor and both voltage readings again. Repeat the procedure using the new values, if necessary.

Note: To simplify the calculation, set the calibration factor to 1.0000 and then repeat the calibration procedure from step 3.

8. Press OFF to stop the generator set.

$$(V_{\text{meter}} \div V_{\text{control}}) \times F_{\text{old}} = F_{\text{new}}$$

V_{meter} = Voltmeter reading

V_{control} = Voltage displayed on controller

F_{old} = Genset Calibration Factor Voltage, L1-L2, from SiteTech before calibration

F_{new} = New value to enter for Genset Calibration Factor Voltage, L1-L2, in SiteTech

Example:

Voltmeter reading: 241.2

Controller display: 240

Old calibration factor (from SiteTech): 1.0063

New calibration factor:

$$(241.2 \div 240) \times 1.0063 = \mathbf{1.0113}$$

Figure 3-14 Voltage Calibration Factor

Genset Calibration	
Genset Calibration Factor Voltage L1-L2	0.980300
Genset Calibration Factor Voltage L2-L3	0.986000
Genset Calibration Factor Voltage L3-L1	0.990000
Genset Calibration Factor Voltage L1-N	1.000000
Genset Calibration Factor Current L1	1.040000
Genset Calibration Factor Current L2	1.040000
Genset Calibration Factor Current L3	1.040000
Current Transformer Calibration At No Load	3.5
Current Transformer Calibration At Full Load	121.5

1. Voltage calibration factor

Figure 3-15 Voltage Calibration Factor in SiteTech™

3.8 Setting the OnCue Plus Password

If the Kohler® OnCue® Plus Generator Management System is used to monitor the generator set, reset the OnCue password as described in Section 3.8.1 for the RDC2 or Section 3.8.2 for the DC2 controller.

3.8.1 RDC2 Controller

Refer to Figure 3-16 during this procedure.

1. Press Select and then press the down arrow button to navigate to the networking Information menu.
2. Press Select. Networking Status is displayed.
3. Press the Down arrow button. Networking Configuration is displayed.
4. Press Select. Reset OnCue Password is displayed.
5. Press and HOLD the Select button until Reset OnCue Password? No appears. The word No will flash.

6. Press the Up arrow button to change the word No to Yes.
7. Press Select to reset the password. The generator set serial number and new password are displayed for 10 seconds. Be sure to write down the new password for entry into OnCue Plus program.

3.8.2 DC2 Controller

1. Press the OFF button and verify that the generator set is not running.
2. Press and HOLD the EXERCISE button until *Press Again to Reset OnCue PW* is displayed.
3. Release the EXERCISE button and press it again within 5 seconds.

Note: If the EXERCISE button is not pressed within 5 seconds, the controller exits the password reset mode.

4. The generator set serial number and new password will be displayed for 10 seconds. Be sure to write down the new password for entry into OnCue Plus program.

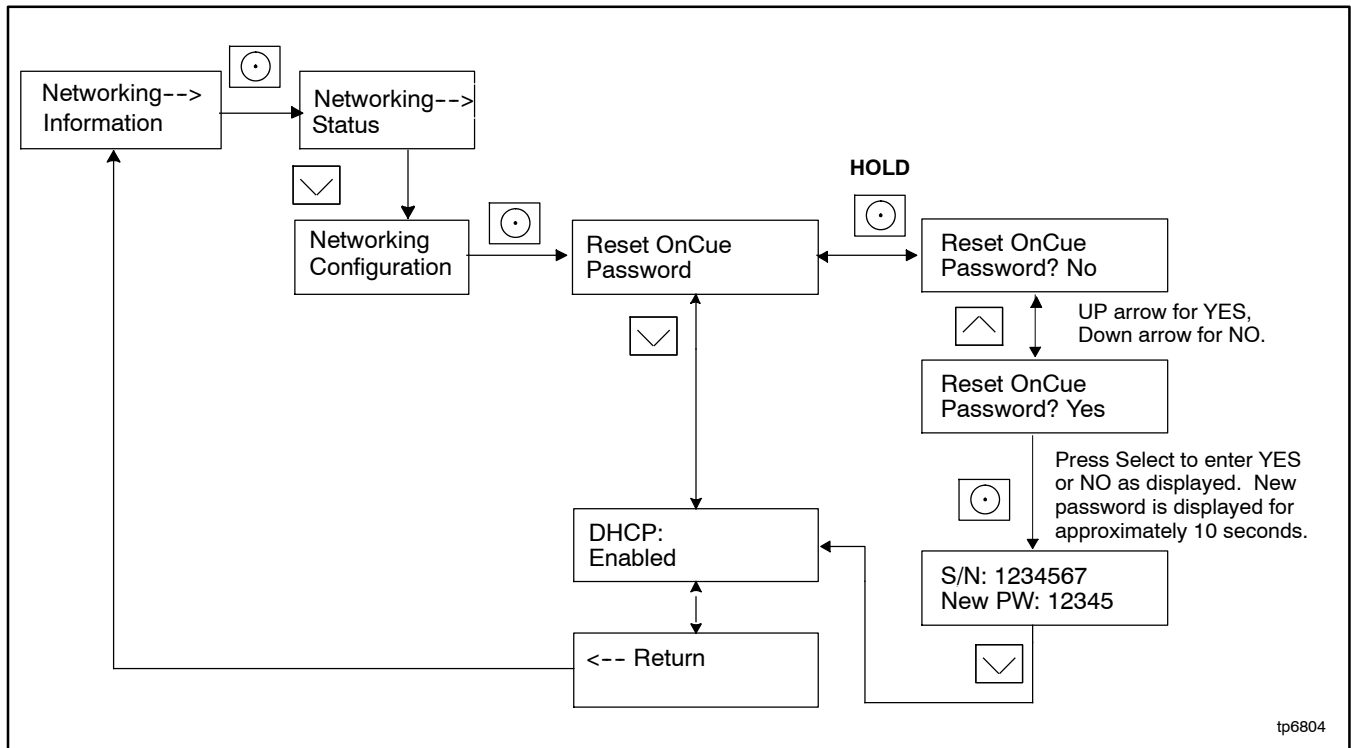

Figure 3-16 Setting the OnCue Plus Password, RDC2

Notes

4.1 Introduction

Corrective action and testing in many cases requires knowledge of electrical systems and electronic circuits. Testing and service must be performed by an authorized distributor/dealer or trained service technician.

Refer to the engine service manual for engine service information. See the List of Related Materials for the document part number.

If the troubleshooting procedures in this section identify a failed part, refer to the parts catalog for replacement part numbers. See the List of Related Materials in the Introduction for the parts catalog number.

4.2 Theory of Operation, Electronic Start Sequence

The following steps trace the electronic system as different leads and components are energized during the start sequence. A start signal can come from any of the following:

- Pressing the Run button on the RDC2 or DC2 controller
- A remote start signal through RBUS (from an RXT transfer switch, for example)
- Closing a contact across engine start connections 3 and 4 (remote start/stop switch or non-RBUS transfer switch engine start signal)
- A start signal over Ethernet from OnCue Plus

The start signal begins the series of events that adds fuel, ignition, and engine crank to the start sequence. Use the steps below and refer to the wiring schematics in Section 7 to assist with troubleshooting and checking for loose connections or damaged leads.

1. Engine Crank

- a. When the start signal is received, the RDC2 or DC2 controller energizes FP and lead 71.
- b. FP provides battery flashing to the rotor field.
- c. Lead 71 energizes the starter relay, P10 or crank relay on the schematic.
- d. The starter relay closes the starter relay contact which energizes the start solenoid.

- e. The start solenoid closes and energizes the starter motor, which cranks (turns) the engine.
- f. The engine rotation along with field excitation produces alternator voltage.

2. Fuel and Ignition

- a. When cranking is initiated, the RDC2/DC2 controller will begin to monitor output voltage amplitude (L1-L2) and auxiliary winding frequency (55-66).
- b. When the RDC2/DC2 controller detects acceptable voltage (L1-L2) or frequency (55-66), the RDC2/DC2 controller energizes wire 70, removes the ground to the ignition module.

(1) If acceptable voltage or frequency is not detected within 3 seconds, the cranking cycle will terminate and a crank pause will begin.

- c. Lead 70 energizes run relay P11, energizing the fuel valve to allow fuel to flow to the carburetor and energizing the ignition, producing ignition spark.
- d. When the RDC2 controller senses alternator voltage or frequency, the RDC2 controller also energizes and governs the stepper motor through leads 1A, 1B, 2A, and 2B.
- e. The stepper motor actuates the throttle arm on the carburetor allowing fuel to enter the engine.
- f. The RDC2/DC2 controller senses speed based on voltage buildup in windings 55 and 66. When the controller senses that the engine has reached 1000 RPM for the 8RESV or 750 RPM for the 10/12RESV, the RDC2/DC2 controller will drop power to lead 71, ending the start sequence.
- g. If running speed is not achieved within 15 seconds, the cranking cycle will terminate and a crank pause will begin.
- h. If successful starting is not achieved after 3 cranking cycles, an OverCrank fault will occur.

4.3 Initial Checks

When troubleshooting, always check for simple problems first. Check for the following common problems before replacing parts:

- **Loose connections or damaged wiring.**
- **Dead battery.**
- **Inadequate fuel supply.** Check for damaged primary or secondary fuel regulators, loose connections to the fuel solenoid valve, a damaged or closed fuel shutoff valve, an empty LPG fuel tank, or other problems with the fuel supply. Check the fuel supply pressure to the generator set. See Section 5.13, Fuel Systems.
- **Fault shutdown.** Check for a fault message on the controller display. Section 4.9 describes the warning and shutdown fault messages. If a fault message is displayed, identify and correct the cause of the fault condition. Then press the OFF button on the controller to clear the fault.
- **Incorrect controller settings.** Always check the controller settings before replacing the controller. See Section 3.3.1 for controller settings. Refer to the operation manual for instructions to check and change the controller settings from the controller keypad, or use a personal computer and Kohler® SiteTech™ software.

4.4 USB Port

The USB port is accessible from the front of the controller. See Figure 4-2.

Section 3.3 lists controller settings. Some settings can be changed from the controller keypad. All other adjustable settings require a personal computer (laptop) with Kohler® SiteTech™ software for changes. Use a USB cable with a mini-B connector to connect the controller's USB port to your PC.

See TP-6701, SiteTech™ Software Operation Manual, for software operation instructions.

4.5 Circuit Protection

Line Circuit Breaker

The line circuit breaker interrupts the generator output in the event of an overload condition or a fault in the wiring between the generator and the load. If the circuit breaker trips, reduce the load and check the wiring.

Auxiliary Winding Circuit Breaker

The auxiliary winding circuit breaker (mini-breaker) in the connection area protects the alternator's auxiliary winding. If the breaker trips, check connections 55, 66, FP, and FN to the alternator.

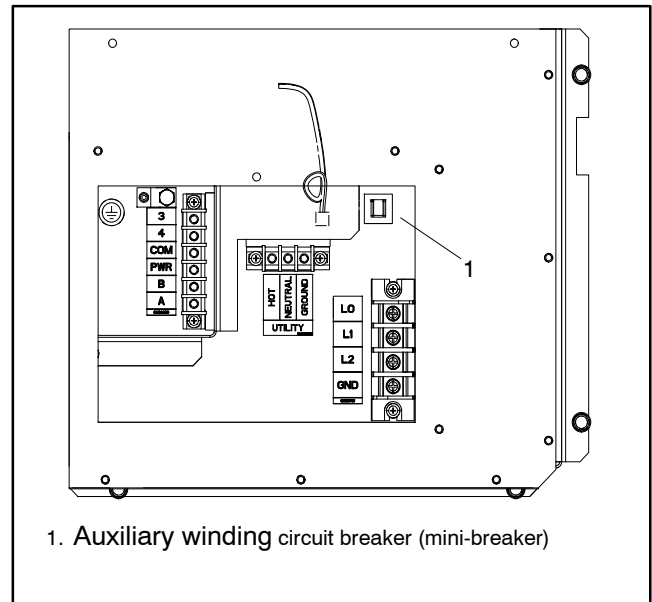

Figure 4-1 Connection Area (cover removed)

Controller Internal Circuit Protection

The controller is equipped with internal circuit protection for accessory and main power overload conditions. Press OFF to reset.

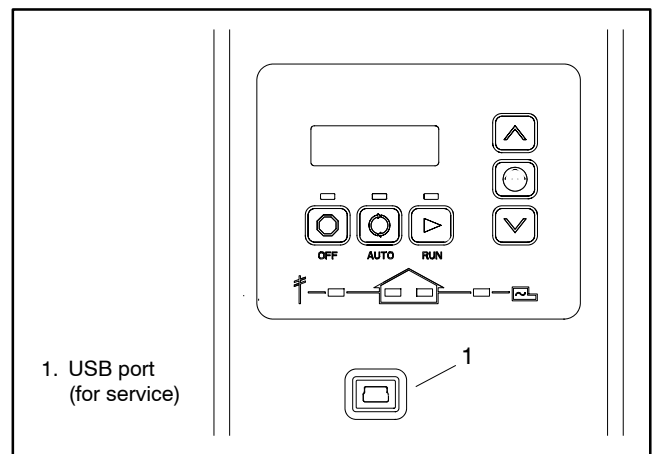

Figure 4-2 USB Port

4.6 Thermostat Information

8RESV(L), 10RESV(L), and 12RESV(L) generators include a resettable thermostat in the air intake compartment. The thermostat detects excess heat inside the enclosure. If the thermostat trips, the generator will shut down and the controller will display a fault (underspeed, underfrequency, or undervoltage). If the thermostat trips for some reason other than high temperature (i.e. a nuisance trip), follow these steps to reset the thermostat.

1. Disconnect the utility power to the generator by opening (turning OFF) the corresponding circuit breaker at the building's distribution panel.
2. Open the enclosure roof.
3. Press the button on the thermostat to reset it. See Figure 4-3 for the thermostat location.
4. Reconnect utility power to the generator set by closing the circuit breaker in the distribution panel.
5. Reset the fault on the RDC2/DC2 controller. Refer to the generator Operation Manual for instructions, if necessary.

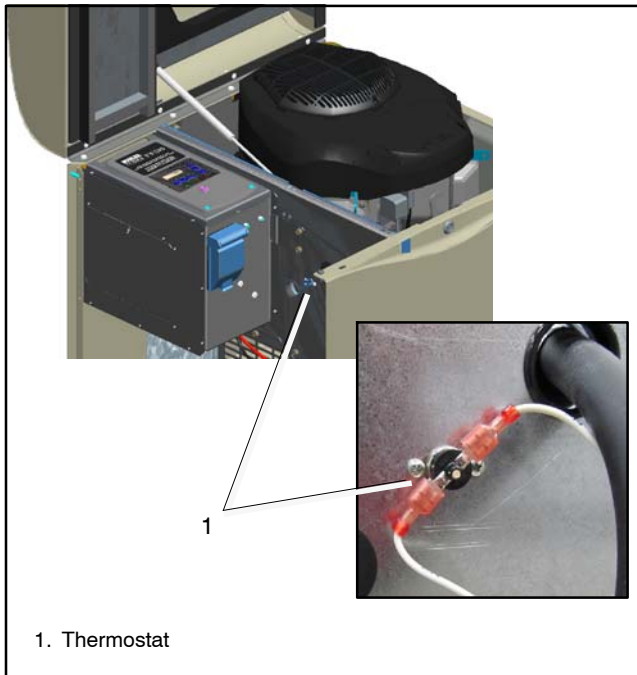
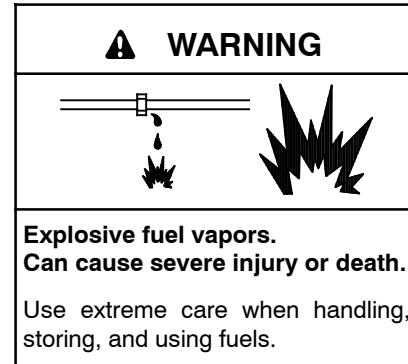

Figure 4-3 Thermostat Location

4.7 OnCue Plus Troubleshooting

See TP-6928, OnCue® Plus Software Operation Manual, for troubleshooting instructions for the OnCue Plus Generator Management System.

4.8 Fuel System Troubleshooting



The fuel system. Explosive fuel vapors can cause severe injury or death. Vaporized fuels are highly explosive. Use extreme care when handling and storing fuels. Store fuels in a well-ventilated area away from spark-producing equipment and out of the reach of children. Never add fuel to the tank while the engine is running because spilled fuel may ignite on contact with hot parts or from sparks. Do not smoke or permit flames or sparks to occur near sources of spilled fuel or fuel vapors. Keep the fuel lines and connections tight and in good condition. Do not replace flexible fuel lines with rigid lines. Use flexible sections to avoid fuel line breakage caused by vibration. Do not operate the generator set in the presence of fuel leaks, fuel accumulation, or sparks. Repair fuel systems before resuming generator set operation.

Gas fuel leaks. Explosive fuel vapors can cause severe injury or death. Fuel leakage can cause an explosion. Check the LPG vapor or natural gas fuel system for leakage by using a soap and water solution with the fuel system test pressurized to 6–8 ounces per square inch (10–14 inches water column). Do not use a soap solution containing either ammonia or chlorine because both prevent bubble formation. A successful test depends on the ability of the solution to bubble.

LPG liquid withdrawal fuel leaks. Explosive fuel vapors can cause severe injury or death. Fuel leakage can cause an explosion. Check the LPG liquid withdrawal fuel system for leakage by using a soap and water solution with the fuel system test pressurized to at least 90 psi (621 kPa). Do not use a soap solution containing either ammonia or chlorine because both prevent bubble formation. A successful test depends on the ability of the solution to bubble.

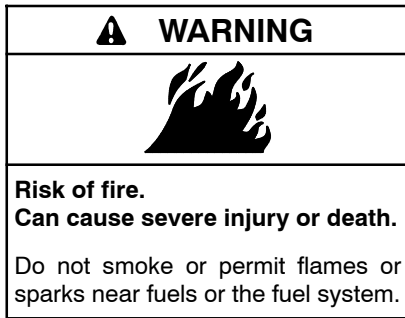

4.9 Fault Messages

The RDC2 controller displays fault messages to aid in troubleshooting. Fault messages, descriptions, and recommended checks are listed in Figure 4-4.

Fault messages will also appear in the Event History in SiteTech. The wording of the message in the Event History may vary slightly from the message shown on the controller display.

Servicing the fuel system. A flash fire can cause severe injury or death. Do not smoke or permit flames or sparks near the carburetor, fuel line, fuel filter, fuel pump, or other potential sources of spilled fuels or fuel vapors. Catch fuels in an approved container when removing the fuel line or carburetor.

- Check primary fuel regulator outlet pressure. This is the line pressure.
- Check the primary regulator vent for obstructions and clean, if necessary.
- Check fuel shutoff inlet pressure.
- Check secondary fuel regulator inlet pressure.
- Check fuel inlet pressure at the gas mixer.
- Perform fuel system maintenance if necessary. See Section 2.8, Fuel System Maintenance.

Identify and correct the cause of the fault condition. Refer to the troubleshooting charts in Section 4.11 for additional recommendations. Then press the OFF button to reset the controller after a fault shutdown.

Fault Message	Action	Description/ Comments	Check
AC Sens Loss Shutdwn (Loss of AC sensing shutdown)	Shutdown	The controller shut down the generator because there was less than 5% of rated voltage measured on Phase A for 3 seconds, only in AUTO, only after acceptable voltage (> 5% of UV setting) has been detected.	Check for loose wiring and connections. Check all AC leads. Troubleshoot alternator.
AC Sens Loss Warning (Loss of AC sensing warning)	Warning	The controller has measured less than 5% of rated voltage on Phase A for 1 second, 10 seconds after crank disconnect.	Check for loose wiring and connections. Check all AC leads. Troubleshoot alternator.
Accy PwrOver Warning	Warning	Accessory Power Overload. An over current fault (short circuit) on the accessory controller power output.	Check wiring to accessories. Troubleshoot the accessories. Refer to the documentation provided with the accessories.
Alt Protect Shutdwn	Shutdwn	High generator current has been detected. The generator set shuts down to protect the alternator from damage caused by overheating the windings. (10/12RESV only)	Reduce the load by disconnecting non-essential equipment. Check wiring and troubleshoot connected equipment. Check for phase imbalance. Check for very high power factor loads.
ATS ComError Warning (ATS communication error)	Warning	The controller has lost communications with the RXT ATS that had previously been communicating properly.	Check connection to ATS module.
<p>* Programmable Interface Module (PIM) required. † Applies during exercise runs and normal operation.</p>			

Fault Message	Action	Description/ Comments	Check
ATS Fail Xfr Warning (ATS fail to transfer)	Warning	The RXT ATS has reported a fail to transfer, the digital output for ATS Fail To Transfer (PIM) is active (contacts closed).	Consult ATS manual for troubleshooting.
ATS PhaseRot Warning (ATS phase rotation)	Warning	The RXT ATS has reported a Phase Rotation Mismatch (3 phase only) and the ATS will not transfer.	Check wiring to ATS. Consult ATS manual for troubleshooting.
Aux Input Shutdwn * (Auxiliary input shutdown)	Shutdown	The controller shut down the generator because the digital input for a custom shutdown (AuxiliaryInputShutdown - PIM) was activated (low).	Check customer equipment connected to the PIM module.
Aux Input Warning * (Auxiliary input warning)	Warning	The digital input for a custom warning (AuxiliaryInputWarning - PIM) is active (low).	Check customer equipment connected to the PIM module.
Batt Chg Flt Warning * (Battery charger fault warning)	Warning	The digital input for Battery Charger Fault Warning (PIM) is active (low). For an external battery charger only, not applicable to the RDC2 built-in battery charging.	Check customer equipment connected to the PIM module.
Battery CRLow Warning †	Warning	Battery voltage dropped to 11 VDC or less for 30 seconds or more.	Check engine starting battery. Check battery charger DC output voltage from RDC2 on P1-1 to the battery.
Battery High Warning	Warning	The controller has measured battery voltage that is above the high warning setting for 10 seconds or more. Operates during exercise and normal operation.	Check engine starting battery.
Battery Low Warning †	Warning	The controller has measured battery voltage that is below the low warning setting for 90 seconds or more. The battery voltage is checked before allowing an exercise to start.	Check engine starting battery. Check battery charger DC output voltage from RDC2 on P1-1 to the battery.
Chk DateTime Warning (Check date and time warning)	Warning	DC power to the controller has been interrupted and the date and time may not be correct. Event history may not have accurate time/date stamps.	Verify the time and date settings to ensure proper operation of scheduled operations and for event history logging.
Emerg Stop Shutdwn	Shutdown	The controller shut down the generator because the emergency stop circuit was tripped (open circuit).	Check E-stop circuit for open switches, broken wires, disconnected wires, etc.
Engine M/N Invalid Shutdwn	Shutdown	Generator model number has not been entered. (Engine model number is selected automatically based on generator set model.)	Enter the generator set model number from the RDC2 keypad, or use SiteTech to select the genset model number.
Engine Speed High Shutdwn	Shutdown	The controller shut down the generator because engine speed, as calculated from AC frequency, was above the high speed setting for 0.3 seconds or more.	Troubleshoot engine operation per the engine service manual.
Engine Speed Low Shutdwn	Shutdown	The controller shut down the generator, after crank disconnect, because engine speed, as calculated from AC frequency, was below the low speed setting for 3 seconds or more.	Troubleshoot engine operation per the engine service manual.
Exer Not Sch Warning	Warning	There is no exercise scheduled.	Set the exercise schedule.
* Programmable Interface Module (PIM) required.			
† Applies during exercise runs and normal operation.			

Fault Message	Action	Description/ Comments	Check
Frequency High Shutdwn	Shutdown	The controller shut down the generator because the frequency measured on Phase A exceeded the high frequency setting for 10 seconds, 10 seconds or more after crank disconnect.	Troubleshoot engine operation per the engine service manual.
Frequency Low Shutdwn †	Shutdown	The controller shut down the generator because the frequency measured on Phase A was less than the low limit for 10 seconds or the measured frequency was 10 Hz or more less than rated for 60 seconds or more, 10 seconds or more after crank disconnect.	Troubleshoot engine operation per the engine service manual.
Fuel Leak Shutdwn *	Shutdown	The controller shut down the generator because the digital input for Fuel Tank Leak Shutdown (PIM) was activated (low).	Check customer equipment connected to the PIM module.
Fuel Leak Warning *	Warning	The digital input for Fuel Tank Leak Warning (PIM) is active (low).	Check customer equipment connected to the PIM module.
Fuel Level CrHi Warning *	Warning	The digital input for Critically High Fuel Level Warning (PIM) is active (low).	Check customer equipment connected to the PIM module.
Fuel Level High Warning *	Warning	The digital input for High Engine Fuel Level Warning (PIM) is active (low).	
Fuel Level Low Shutdwn *	Shutdown	The controller shut down the generator because the digital input for Low Fuel Level Shutdown (PIM) was activated (low).	Check customer equipment connected to the PIM module.
Fuel Level Low Warning *	Warning	The digital input for Low Fuel Level Warning (PIM) is active (low).	
GenBrkerOpen Warning (Generator Circuit Breaker Open)	Warning	There is voltage at the generator set but no voltage measured on the emergency side of the ATS (Model RXT transfer switch required).	Check line circuit breaker. Check for and correct short circuits or overloading on the load side before resetting the circuit breaker.
Genset S/N Unaval Warning	Warning	Generator serial number parameter not populated or is invalid.	If available, reenter the correct or valid Serial Number. Use SiteTech to load the saved parameter file for this generator.
Ground Fault Warning *	Warning	The digital input for Ground Fault Warning (PIM) is active (low).	Check customer equipment connected to the PIM module.
Lo Crank Vlt Warning	Warning	During cranking, the controller measured battery voltage less than 60% (7.2V or 14.4V) for 6 seconds or more during cranking.	Check cranking battery.
Locked Rotor Shutdwn	Shutdown	The controller shut down the generator because no rotation of the engine or alternator was detected, for 3 seconds or more, during cranking.	Check cranking circuit. Troubleshoot the engine. See Engine Service Manuals. Check alternator connections to controller and auxiliary winding circuit breaker. Troubleshoot the alternator.
MainPwrOverL Shutdwn	Shutdown	The internal current limit circuit has tripped, indicating an overcurrent condition on the DC power supply circuit.	Check crank, run, and flash relay circuits for short circuits.
<p>* Programmable Interface Module (PIM) required. † Applies during exercise runs and normal operation.</p>			

Fault Message	Action	Description/ Comments	Check
Maint Req'd Warning	Warning	Engine run time, or calendar days, has exceeded the maintenance reminder setting.	Change the oil and perform other maintenance according to the service schedule in Section 2.1. Reset the maintenance timer after service. See Section 2.2.5.
Not In Auto Warning	Warning	The RDC2 controller is not in AUTO. The generator will not start from an ATS or remote device. The digital output for Not In Auto (PIM) is active (contacts closed).	Press the Auto button to ensure automatic system operation.
Oil Temperature High Warning	Warning	Oil temperature higher than 300°F (149°C).	See Overheats in the troubleshooting charts in Section 4.11.
Oil Temperature High Shutdown	Shutdown	Oil temperature higher than 325°F (163°C).	
OB1 CommLoss (PIM, load management device, or RXT)	Warning	Communications with option board #1 has been lost.	Check RBUS wiring to inoperative option board.
OB2 CommLoss (PIM, load management device, or RXT)	Warning	Communications with option board #2 has been lost.	Check RBUS wiring to inoperative option board.
OB3 CommLoss (PIM, load management device, or RXT)	Warning	Communications with option board #3 has been lost.	Check RBUS wiring to inoperative option board.
OB4 CommLoss (PIM, load management device, or RXT)	Warning	Communications with option board #4 has been lost.	Check RBUS wiring to inoperative option board.
Oil Level Low Shutdwn *	Shutdown	The controller shut down the generator because the digital input for Low Oil Level Shutdown (PIM) was activated (low).	Check customer equipment connected to the PIM module.
Oil Level Low Warning *	Warning	The digital input for Low Oil Level Warning (PIM) is active (low).	Check customer equipment connected to the PIM module.
Oil Pressure Low Shutdwn	Shutdown	The low oil pressure switch was closed for 5 seconds or more, indicating low oil pressure. Function is inhibited until 30 seconds after crank disconnect.	Check for oil leaks. Check the oil level and add oil if low. Check the oil pressure sensor; see Engine Service Manuals.
Oil Pressure OpenCR Warning	Warning	When the generator set is not running and controller is in OFF or AUTO, the low oil pressure switch is not working properly.	Check the oil pressure switch connection. Replace the LOP switch if necessary. See Section 5.12.2.
Over Crank Shutdwn	Shutdown	The controller shut down the generator, and ceased cranking, because the engine was not successfully started after the completion of the last of the crank cycles setting delay 15 seconds.	Check fuel supply. Check cranking circuit. Reset the thermostat. Check cranking battery. Troubleshoot engine; see Engine Service Manuals.
RBUS ComError Warning	Warning	The controller has lost communications with a PIM, load management device that had previously been communicating properly.	Check connection to the PIM or load management device.
* Programmable Interface Module (PIM) required.			
† Applies during exercise runs and normal operation.			

Fault Message	Action	Description/ Comments	Check
Spd Sens Flt Shutdwn (Speed sensor fault)	Shutdown	The controller shut down the generator because the speed signal was lost.	Check leads 55, 66, F+, and F- between the alternator and the controller. This fault also occurs if the engine stalls; check the engine and see the troubleshooting chart in Section 4.11.
Total Power High Shutdwn	Shutdown	Measured load is greater than 102% of the generator set power rating for more than 1 minute. (10/12RESV only)	Reduce the load by disconnecting non-essential equipment. Check wiring and troubleshoot connected equipment. Check for phase imbalance. Check for very high power factor loads.
Volts L1-L2 High Shutdwn †	Shutdown	The controller shut down the generator because the voltage measured from Phase A to Phase B exceeded the high limit for a time greater than the delay setting 2 seconds.	Troubleshoot alternator. See Section 4.11, Troubleshooting Charts, and Section 5, Component Testing and Adjustment.
Volts L1-L2 Low Shutdwn †	Shutdown	The controller shut down the generator because the voltage measured from Phase A to Phase B was greater 5% of rated, but less than the low voltage setting for a time greater than the delay setting 10 seconds.	Troubleshoot alternator. See Section 4.11, Troubleshooting Charts, and Section 5, Component Testing and Adjustment.
Volts L2-L3 High Shutdwn †	Shutdown	The controller shut down the generator because the voltage measured from Phase B to Phase C exceeded the high limit for a time greater than the delay setting 2 seconds.	Troubleshoot alternator. See Section 4.11, Troubleshooting Charts, and Section 5, Component Testing and Adjustment.
Volts L2-L3 Low Shutdwn †	Shutdown	The controller shut down the generator because the voltage measured from Phase B to Phase C was greater 5% of rated, but less than the low voltage setting for a time greater than the delay setting (default 10 seconds).	Troubleshoot alternator. See Section 4.11, Troubleshooting Charts, and Section 5, Component Testing and Adjustment.
Volts L3-L1 High Shutdwn †	Shutdown	The controller shut down the generator because the voltage measured from Phase C to Phase A exceeded the high limit for a time greater than the delay setting. (default delay time is 2 seconds.)	Troubleshoot alternator. See Section 4.11, Troubleshooting Charts, and Section 5, Component Testing and Adjustment.
Volts L3-L1 Low Shutdwn †	Shutdown	The controller shut down the generator because the voltage measured from Phase C to Phase A was greater 5% of rated, but less than the low voltage setting for a time greater than the delay setting.	Troubleshoot alternator. See Section 4.11, Troubleshooting Charts, and Section 5, Component Testing and Adjustment.
* Programmable Interface Module (PIM) required. † Applies during exercise runs and normal operation.			

Figure 4-4 Fault Messages Displayed on the RDC2 Controller

4.10 Status Messages

The following messages are displayed to show system status. Notices are displayed in the Event History in SiteTech when active but do not appear on the controller display. Some status messages are displayed when a

digital input is activated; the optional Programmable Interface Module (PIM) is required for display of those messages as noted in the table.

Status Message	Action	Description/ Comments	Check
Always Off *	Notice	OnCue® Plus has been used to control this PIM digital output. The digital output is no longer controlled by the generator set.	Click on the PIM output in OnCue Plus to turn the output on or off. See the OnCue Plus Operation Manual.
Always On *	Notice	Applies to digital outputs B3 through B6 on the PIM only.	To reset the PIM digital output to a function controlled by the generator set, use SiteTech software to re-assign the output event.
Auto Locked * (Chicago Code Active)	Notice	The digital output for Chicago Code Active (PIM) is active (contacts closed), indicating the digital input for Chicago Code Active (PIM) is active (low) and thus master switch is locked in the AUTO position.	Check customer equipment connected to the PIM module.
Common Fault	Notice	The digital output for Common Fault (PIM) is active (contacts closed), indicating the generator is shutdown for any (all) fault.	Check for faults and troubleshoot any/all fault conditions individually.
Common Warnng	Notice	The digital output for Common Warning (PIM) is active (contacts closed), indicating that any (all) warning is active.	Check for warnings and troubleshoot any/all warning conditions individually.
Default Pars Warning (Default Parameters)	Warning	The controller has been loaded with default parameters.	Configure settings as required for desired operation.
Emerg Pwr On (Emergency Power System Supplying Load)	Notice	The digital output for EPS Supplying Load (PIM) is active (contacts closed), indicating there is current output (>5%) from the alternator, only if CTs are installed.	Nothing to check.
Eng Cooldown	Notice	The digital output for Engine Cooldown Active (PIM) is active (contacts closed), indicating the generator is running in cooldown. (Delay 5 min.)	Check remote start circuit if it was expected that the generator should be running. Consult ATS operations manual.
Fuel Spill *	Notice	The digital output for Fuel Spill (PIM) is active (contacts closed), indicating any of the digital inputs for Fuel Tank Leak Warning, Fuel Tank Leak Shutdown, Engine Fuel Level Warning or Engine Fuel Level Critically High (PIM) is active (low).	Check customer equipment connected to the PIM module.
* Programmable Interface Module (PIM) required.			
† Load management device required (LCM, load shed kit, or RXT with combined interface/load management board).			

Status Message	Action	Description/ Comments	Check
Gen Running	Notice	The digital output for Generator Running (PIM) is active (contacts closed), indicating the generator is running.	Check controller front panel buttons for potential RUN command. If in AUTO, check remote start lines. Consult ATS operation manual for events that may cause the generator to start.
Low Fuel *	Notice	The digital output for Low Fuel (PIM) is active (contacts closed), indicating any of the digital inputs for Low Fuel Pressure Warning, Low Fuel Level Warning or Low Fuel Level Shutdown (PIM) is active (low).	Check customer equipment connected to the PIM module.
Minor Fault	Notice	The digital output for Minor Fault (PIM) is active (contacts closed), indicating either the digital input for Ground Fault Indicator Warning (PIM) is active (low) or the controller detected Low Cranking Voltage.	Check customer equipment connected to the PIM module. Check cranking battery condition.
NormSrcUnavl (RXT required)	Notice	The normal power source (source1) is disconnected, unavailable or unacceptable.	Check for utility source power outage. Check wiring and connections to the ATS.
OB1 CommLoss (PIM, load management device, or RXT)	Notice	Communications with option board #1 has been lost.	Check RBUS wiring to inoperative option board.
OB2 CommLoss (PIM, load management device, or RXT)	Notice	Communications with option board #2 has been lost.	Check RBUS wiring to inoperative option board.
OB3 CommLoss (PIM, load management device, or RXT)	Notice	Communications with option board #3 has been lost.	Check RBUS wiring to inoperative option board.
OB4 CommLoss (PIM, load management device, or RXT)	Notice	Communications with option board #4 has been lost.	Check RBUS wiring to inoperative option board.
Rmt StartCmd (Remote Start Command Issued)	Notice	The controller has received a remote start signal while the master switch is in AUTO, and will go to normal running.	Verify remote start signal. Consult ATS operations manual for cause of generator start.
Run Btn Ack (Run Button Acknowledged)	Notice	The RUN button on the controller has been pushed.	NA
Start Delay (Engine Start Delay Active)	Notice	The digital output for Engine Start Delay (PIM) is active (contacts closed), indicating the engine is in between active cranking cycles.	NA
System Ready	Notice	The digital output for System Ready (PIM) is active (contacts closed), indicating the generator has no active faults or warnings.	NA
VSpdStartCmd (Variable Speed Start Command)	Notice	A diagnostic exercise request has been received by the controller.	Check for a remote exercise command from OnCue Plus.
* Programmable Interface Module (PIM) required.			
† Load management device required (LCM, load shed kit, or RXT with combined interface/load management board).			

Status Message	Action	Description/ Comments	Check
Load Shed 1 Status Info †	Notice	The digital output for LoadPriority1Shed is active (contacts closed), indicating the 1st priority load shed (load management device) has been activated.	Remove loads as required. Check building wiring for proper load distribution. Check engine fuel supply.
Load Shed 2 Status Info †	Notice	The digital output for LoadPriority2Shed is active (contacts closed), indicating the 2nd priority 1st priority load shed (load management device) has been activated.	Remove loads as required. Check building wiring for proper load distribution. Check engine fuel supply.
Load Shed 3 Status Info †	Notice	The digital output for LoadPriority3Shed is active (contacts closed), indicating the 3rd priority 1st priority load shed (load management device) has been activated.	Remove loads as required. Check building wiring for proper load distribution. Check engine fuel supply.
Load Shed 4 Status Info †	Notice	The digital output for LoadPriority4Shed is active (contacts closed), indicating the 4th priority 1st priority load shed (load management device) has been activated.	Remove loads as required. Check building wiring for proper load distribution. Check engine fuel supply.
Load Shed 5 Status Info †	Notice	The digital output for LoadPriority5Shed is active (contacts closed), indicating the 5th priority 1st priority load shed (load management device) has been activated.	Remove loads as required. Check building wiring for proper load distribution. Check engine fuel supply.
Load Shed 6 Status Info †	Notice	The digital output for LoadPriority6Shed is active (contacts closed), indicating the 6th priority 1st priority load shed (load management device) has been activated.	Remove loads as required. Check building wiring for proper load distribution. Check engine fuel supply.
* Programmable Interface Module (PIM) required.			
† Load management device required (LCM, load shed kit, or RXT with combined interface/load management board).			

Figure 4-5 Status Messages Displayed on the RDC2 Controller

4.11 Troubleshooting Chart

Use the following table as a reference in troubleshooting individual problems. Generator set faults are listed in groups and include likely causes and remedies. The

simplest and most likely causes of the problem are listed first; follow the recommendations in the order shown. The reference column provides additional sources of information in this and related manuals regarding the problem and solution.

Problem	Possible Cause	Test	Corrective Action	Reference	
Generator set engine does not crank	Battery connections	Check for reversed or poor battery connections.	Correct and tighten battery connections.	—	
	Weak or dead battery	Check the battery voltage. Test battery according to battery manufacturer's recommendations.	Recharge or replace battery.	O/M	
		Check battery charger connections and utility power connection to the generator set.	Tighten connections. Connect 120VAC power to the genset terminal block.	I/M	
	Open circuit in engine/controller connections	Check for loose connections. Check the wire harness continuity.	Tighten connections. Replace harness or harness leads if damaged.	Section 5.16, W/D Section 7	
	Poor ground (-) connection	Test ground connection.	Clean and retighten.	—	
	Starter relay	Check connections to the starter relay.	Tighten connections. Replace wiring if damaged.	Section 5.15 W/D Section 7	
		Check continuity of circuit.		Section 5.16 W/D Section 7	
		Check that the starter relay picks up when 12 VDC is applied at lead 71 connection.	Replace starter relay.	W/D Section 7	
	Starter	Check starter connections.	Tighten connections. Replace wiring if damaged.	W/D Section 7	
		Troubleshoot the starter. See the engine service manual for instructions.	Rebuild or replace starter.	Engine S/M	
	Controller	Check for 12 VDC to the controller.	Check battery and connections.	W/D Section 7	
		Check the genset model, engine model, and other controller settings.	Adjust controller settings, if necessary.	Section 3.3	
		Troubleshoot the controller as described in Section 4.12.	See Section 4.12.	Section 4.12	
	W/D = Wiring Diagram(s) (Section 7) S/S = Generator Set Specification Sheet O/M = Generator Set Operation Manual I/M = Generator Set Installation Manual Engine S/M = Engine Service Manual				
	* RDC2 controller settings can be checked and adjusted using the controller user interface or using a personal computer running SiteTech software. DC2 controller settings can only be changed using SiteTech.				

Problem	Possible Cause	Test	Corrective Action	Reference
Cranks but does not start	No fuel. Thermostat has tripped.	Verify that manual fuel valve is open. Check fuel supply tank (LPG).	Open (turn on) manual fuel valve. Reset the thermostat. Contact fuel supplier to add fuel to fuel supply tank (LPG).	Section 4.6
	Insufficient fuel pressure	Check fuel pressure to the generator set. Verify adequate fuel pressure and pipe size for the generator set plus all other gas appliances.	Contact fuel supplier to replace fuel supply lines with larger pipe and replace gas meter if fuel pressure is insufficient.	Section 5.13.3
	Fuel regulator/valve	Check regulator/valve operation.	Check regulator/valve operation.	Section 5.13 Section 4
	Weak battery	Check the battery voltage. Check battery charger connections and utility power connection to the generator set.	Recharge or replace battery. Tighten loose connections.	O/M W/D Section 7
	Spark plugs or spark plug connections	Check spark plug wires and connections. Check spark plugs.	Tighten connections. Replace spark plug wires if damaged. Replace or clean and regap spark plugs.	O/M
	Loose connection or open circuit	Check for loose or open connection at the fuel valve (lead 70A) and at the engine spark control module (IGN). Check controller/engine wiring continuity.	Tighten connections. Replace wiring if damaged.	Section 7
	Air cleaner clogged	Check for a dirty air cleaner element.	Replace air cleaner element. Check and replace air cleaner element at the intervals shown in the Service Schedule.	O/M
	Incorrect controller settings	Check the genset model setting.	Enter the correct genset model number setting. Engine model is selected automatically based on genset model.	Section 3.3
	Ignition system spark control or ignition coil	Test according to instructions in the engine service manual.	Adjust or replace components as indicated in engine service manual.	Engine S/M
	Fuel selector valve incorrectly set for the type of fuel used.	Check the fuel selector valve. Check the controller settings.	Turn the selector valve to the correct fuel type, LPG or NG. See Figure 5-32. Use the controller or SiteTech to verify the controller fuel settings for LPG or NG.	Section 5.13.2
	No engine rotation sensed (check for an overcrank or locked rotor fault shutdown)	Check the cranking circuit.	Troubleshoot engine and alternator.	Engine S/M
<p>W/D = Wiring Diagram(s) (Section 7) S/S = Generator Set Specification Sheet O/M = Generator Set Operation Manual I/M = Generator Set Installation Manual Engine S/M = Engine Service Manual</p> <p>* RDC2 controller settings can be checked and adjusted using the controller user interface or using a personal computer running SiteTech software. DC2 controller settings can only be changed using SiteTech.</p>				

Problem	Possible Cause	Test	Corrective Action	Reference
Starts hard	Low battery voltage	Check battery voltage during cranking. Check battery charger connections and utility power connection to the generator set.	Charge battery. Replace battery if necessary. Tighten loose connections.	O/M W/D Section 7
	Air cleaner clogged	Check for a dirty air cleaner element.	Replace element.	O/M
	Fuel mixture adjustment incorrect	Use oxygen sensor to check fuel mixture.	Adjust fuel mixture.	Section 5.13
	Fuel selector valve incorrectly set for the type of fuel used.	Check the fuel selector valve. Check the controller settings.	Turn the selector valve to the correct fuel type, LPG or NG. See Figure 5-32. Use the controller or SiteTech to verify the controller fuel settings for LPG or NG.	Section 5.13.2 Section 3.3
	Spark plug(s)	Check spark plug condition and gap.	Replace or regap spark plug(s).	O/M
	Spark plug wire(s)	Check spark plug wires and connections.	Tighten connections. Replace spark plug wires if damaged.	Engine S/M
	Ignition components (spark control or ignition module)	Test ignition components according to instructions in the engine service manual.	Replace ignition components if necessary.	Engine S/M
	Insufficient fuel pressure	Check fuel pressure to the generator set. Verify adequate fuel pressure and pipe size for the generator set plus all other gas appliances.	Contact fuel supplier to replace fuel supply lines with larger pipe and replace gas meter if fuel pressure is insufficient.	Section 5.13.3
Engine problem.	Troubleshoot the engine.	See engine service manual.	Engine S/M	
Noisy operation	Exhaust system leaks	Check silencer and connections for leaks.	Replace gaskets and exhaust system components as necessary.	—
	Engine not running smoothly	See "Erratic operation," this table.	See "Erratic operation," this table.	—
	Broken or damaged vibromount(s)	Inspect vibromounts.	Replace as necessary.	Section 6
	Loose or vibrating sheet metal/housing	Check for loose screws and rivets.	Retighten screws, replace rivets.	—
	Exhaust piping or air inlets/outlets not securely installed	Inspect for loose parts.	Secure loose parts as necessary.	—
	Excessive engine/generator vibration	Check rotor, crankshaft, bearing, etc. (disassembly of engine and/or alternator may be required).	Check, rotor, crankshaft, bearing, etc. (disassembly of engine and/or alternator may be required).	Engine S/M
Overheats	Inadequate cooling	Inspect engine and enclosure for air intake obstructions.	Clear any air intake obstructions.	O/M
	Air cleaner clogged.	Check for a dirty air cleaner element.	Replace air cleaner element.	O/M
W/D = Wiring Diagram(s) (Section 7) S/S = Generator Set Specification Sheet O/M = Generator Set Operation Manual I/M = Generator Set Installation Manual Engine S/M = Engine Service Manual				
* RDC2 controller settings can be checked and adjusted using the controller user interface or using a personal computer running SiteTech software. DC2 controller settings can only be changed using SiteTech.				

Problem	Possible Cause	Test	Corrective Action	Reference	
Stops suddenly	Fault shutdown	Check for a fault shutdown message on the controller display. Identify the cause of the fault.	Correct the fault and then press the controller's OFF button to reset the controller.	Section 4.9	
	No fuel	Check fuel valves and fuel supply.	Open manual fuel valve. Contact fuel supplier to replenish fuel supply.	—	
	Fuel line restriction	Inspect fuel lines.	Clear restriction.	—	
	Fuel lines too long	Check fuel line length and pipe size.	Contact fuel supplier to replace fuel lines with larger pipe.	Generator set S/S, I/M	
	Air cleaner clogged	Check for a dirty air cleaner element.	Replace air cleaner element.	O/M	
	Spark plug(s)	Check spark plug(s).	Replace or regap plug(s).	O/M	
	Engine overheated (hot engine only)	Check air intake and generator set enclosure air inlets and outlet. Use oxygen sensor to check fuel mixture. Check oil level.	Clear air intake and enclosure air inlets and outlets. Adjust fuel mixture.	O/M	Section 5.13
			Add oil. Check and replace oil at the intervals shown in the Service Schedule.	O/M	
	Low oil pressure (LOP) switch	Check oil pressure. Attempt startup. If unit shuts down, remove lead from LOP switch and reset controller. A successful restart attempt indicates a faulty LOP shutdown switch. Note: Check engine oil pressure before performing test and/or replacing LOP shutdown switch.	See engine S/M. Replace faulty LOP shutdown switch. Note: Check engine oil pressure before performing test and/or replacing LOP shutdown switch.	Section 5.12.2 and Engine S/M	
	Fuel valve/fuel regulator	Check fuel valve connections. Check regulator/valve operation. Check fuel pressure.	Tighten fuel valve connections. Replace damaged wires. Replace regulator or valve .	Section 5.13	
	Engine overloaded	Reduce electrical load and check operation.	Unplug some lights or appliances connected to the generator set.	—	
	Engine speed sensing connections	Check for loose connections: FP, FN, 55, 66, and connections to the line circuit breaker.	Tighten connections. Replace damaged wiring.	W/D, Section 7	
	Ignition module	Test the ignition system according to the instructions in the engine service manual.	Service the ignition system according to the instructions in the engine service manual.	Engine S/M	
Loss of generator output voltage to controller	Check connections at P2 plug. Check continuity of AC sensing leads 11 and 44. See Section 5 for alternator test procedures.	Tighten connections at P2 plug. Replace wiring if damaged.	Section 7 Section 5.4		
		Repair or replace components if necessary, as indicated by tests in Section 5.	Section 5		
W/D = Wiring Diagram(s) (Section 7) S/S = Generator Set Specification Sheet O/M = Generator Set Operation Manual I/M = Generator Set Installation Manual Engine S/M = Engine Service Manual					
* RDC2 controller settings can be checked and adjusted using the controller user interface or using a personal computer running SiteTech software. DC2 controller settings can only be changed using SiteTech.					

Problem	Possible Cause	Test	Corrective Action	Reference
Erratic operation	Air cleaner clogged	Check air filter element.	Replace element.	O/M
	Spark plug(s)	Check spark plug condition and gap.	Replace or regap plugs.	O/M
	Spark plug wire(s)	Check spark plug connections and wires.	Tighten connections. Replace damaged spark plug wires.	Engine S/M
	Fuel selector valve incorrectly set for the type of fuel used.	Check the fuel selector valve. Check the controller settings.	Turn the selector valve to the correct fuel type, LPG or NG. See Figure 5-32. Use the controller or SiteTech to verify the controller fuel settings for LPG or NG.	Section 5.13.2 Section 3.3
	Fuel line restriction	Check fuel lines. Check fuel pipe size.	Clear restricted fuel lines. Contact fuel supplier to install larger diameter pipe.	Section 5.13.3
	Fuel mixture adjustment incorrect	Use oxygen sensor to check fuel mixture.	Adjust fuel mixture.	Section 5.13
	Governor adjustment incorrect	Check governor operation. Check controller engine speed setting. *	Adjust governor. Adjust engine speed setting on controller. *	Section 5.10 Section 3.3
	Ignition system	Test ignition system according to instructions in engine service manual.	Service ignition system according to instructions in engine service manual.	Engine S/M
	Inadequate cooling (hot engine only)	Check air inlet and outlet.	Clear air inlet and outlet.	—
	Other engine service required	See engine service manual.	Service according to instructions in engine service manual.	Engine S/M
High output voltage	Incorrect controller settings	Check genset model, engine model, system voltage, and other controller settings. *	Adjust the controller settings. *	Section 3.3
	Incorrect voltage calibration	Check the voltage calibration.*	Adjust the voltage calibration. *	Section 3.7
	Loose voltage sensing connections	Check connections: stator leads 11 and 44 and P2 controller connection.	Tighten connections.	Section 7 W/D
W/D = Wiring Diagram(s) (Section 7) S/S = Generator Set Specification Sheet O/M = Generator Set Operation Manual I/M = Generator Set Installation Manual Engine S/M = Engine Service Manual				
* RDC2 controller settings can be checked and adjusted using the controller user interface or using a personal computer running SiteTech software. DC2 controller settings can only be changed using SiteTech.				

Problem	Possible Cause	Test	Corrective Action	Reference
Lacks power	Air intake restriction, inadequate cooling	Inspect air intakes and exhaust for obstructions.	Clear air intakes and exhaust area. Maintain clearances shown on the genset dimension drawing.	I/M
		Check air cleaner.	Replace air cleaner element.	O/M
	Generator overloaded	Reduce electrical load and check operation.	Unplug some lights or appliances connected to the generator set.	—
	Spark plug(s)	Check spark plugs.	Regap or replace plug(s).	O/M
	Spark plug connections	Check tightness and condition of spark plug wires.	Tighten or replace spark plug wires.	Engine S/M
	Fuel selector valve incorrectly set for the type of fuel used.	Check the fuel selector valve.	Turn the selector valve to the correct fuel type, LPG or NG. See Figure 5-32.	Section 5.13.2 Section 3.3
		Check the controller settings.	Use the controller or SiteTech to verify the controller fuel settings for LPG or NG.	
	Low fuel pressure	Check fuel pressure at carburetor outlet. Check for adequate fuel pipe size and meter capacity for generator set and all gas-fired appliances.	Contact fuel supplier to replace pipe and/or meter as required to provide sufficient fuel supply pressure for the generator set and all gas-fired appliances.	Section 5.13
	Fuel line restriction	Check fuel pipe size.	Contact fuel supplier to provide larger pipe.	Section 5.13
	Fuel regulator	Check function of fuel regulator.	Repair or replace fuel regulator.	Section 5.13
	Engine not running at rated rpm	Check controller setting for engine model. * Check engine speed.	Select the correct engine model. * Adjust engine speed.	Section 3.3
	Engine power loss	Refer to the engine service manual for troubleshooting and repair instructions.	Refer to the engine service manual for troubleshooting and repair instructions.	Engine S/M
Governor malfunction or misadjustment	Test governor.	Adjust governor.	Section 5.10	
Ignition system	See the engine service manual for service procedures.	See the engine service manual for service procedures.	Engine S/M	
Low output or excessive drop in voltage (continues on next page)	Generator overloaded	Reduce electrical load and check operation.	Unplug some lights or appliances connected to the generator set.	—
	Incorrect controller settings	Check the controller settings. *	Adjust the controller settings. *	Section 3.3
	Incorrect controller voltage settings	Check the controller voltage settings. *	Adjust the controller voltage settings. *	Section 3.3
	Alternator or control system	Perform separate excitation procedure to isolate problem to the alternator or the control system.	Troubleshoot the alternator or control system as indicated by test results.	Section 5.3
	Controller	Check the controller settings.	Adjust controller settings.	Section 3.3
		Test the controller as described in Section 4.12.	See Section 4.12.	Section 4.12
	Rotor	Test rotor for open, grounded, or shorted windings.	Replace rotor if faulty windings are found.	Section 5.5
	Stator	Test stator for open, grounded, or shorted windings.	Replace stator if faulty windings are found.	Section 5.4
W/D = Wiring Diagram(s) (Section 7) S/S = Generator Set Specification Sheet O/M = Generator Set Operation Manual I/M = Generator Set Installation Manual Engine S/M = Engine Service Manual				
* RDC2 controller settings can be checked and adjusted using the controller user interface or using a personal computer running SiteTech software. DC2 controller settings can only be changed using SiteTech.				

Problem	Possible Cause	Test	Corrective Action	Reference
Low output or excessive drop in voltage, continued	Brush connection	Check for loose brush connections. Check for loose brush mounting. Check the resistance through the brushes. Resistance through the brushes should be low, 0.1-0.2 ohms without meter lead resistance.	Tighten loose brush connections. Tighten mounting screws. Replace brushes if they show uneven wear or are worn to one-half their original length.	Section 5.7
	Low engine speed causing voltage roll-off	Check system voltage, system frequency, and engine model settings. Check engine speed setting. Engine problem.	Change the controller settings if not correct. * Adjust engine speed setting. Troubleshoot the engine.	Section 3.3 Engine S/M
No output voltage	AC output circuit breaker open	Check for AC voltage on the generator side of circuit breaker. If there is AC voltage on the generator side of the breaker, then a problem in the load circuits is causing the line circuit breaker to trip.	Check for and correct short circuits or overloading on the load side before resetting the circuit breaker.	—
	Alternator or control system	Perform separate excitation procedure to isolate the problem to the alternator or the control system.	Troubleshoot the alternator or control system components as described below and elsewhere in this table.	Section 5.3
	Controller	Check the controller settings.	Adjust controller settings.	Section 3.3
		Troubleshoot the controller as described in Section 4.12.	See Section 4.12.	Section 4.12
	Open wiring, terminal, or pin in buildup circuit	Check wiring.	Replace wiring as necessary.	Section 7 W/D
	Brushes	Inspect brushes.	Replace brushes if worn.	Section 5.7
		Check for brushes sticking in brush holder or broken brush spring.	Replace brush spring or brush assembly.	Section 5.7
		Check that brush holder is securely mounted.	Tighten brush holder screws.	Section 5.7
	Rotor slip rings dirty or corroded	Check slip ring condition.	Clean slip rings as described in Section 5.6. Machine slip rings if necessary.	Section 5.6
	Rotor (open, grounded, or shorted windings)	Check voltage and continuity as described in Section 5.5.	Repair or replace rotor if indicated by the tests.	Section 5.5
Stator (open, grounded, or shorted windings)	Check voltage and continuity as described in Section 5.4.	Repair or replace the stator if indicated by the test results.	Section 5.4	
Aux. winding circuit breaker tripped	Check the breaker in the service access area of the controller. If breaker trips again, check stator.	Reset breaker. If breaker trips again, check stator.	Figure 4-2 Section 5.4	
W/D = Wiring Diagram(s) (Section 7) S/S = Generator Set Specification Sheet O/M = Generator Set Operation Manual I/M = Generator Set Installation Manual Engine S/M = Engine Service Manual				
* RDC2 controller settings can be checked and adjusted using the controller user interface or using a personal computer running SiteTech software. DC2 controller settings can only be changed using SiteTech.				

4.12 Controller Troubleshooting

Refer to the controller troubleshooting table in Figure 4-6 when troubleshooting procedures in Section 4.11 indicate a possible controller problem. Also check the controller display for fault messages and refer to Section 4.9, Fault Messages.

Always check the controller settings before replacing the controller. RDC2 controller settings can be checked

and adjusted through the controller's user interface or using a personal computer and Kohler® SiteTech™ software. The generator set operation manual contains the instructions for checking and changing the controller settings. The DC2 controller settings can only be changed using SiteTech™. See TP-6701, SiteTech Software Operation Manual. Kohler® SiteTech™ software is available to authorized distributors and dealers.

Problem	Possible Cause	Corrective Action	Reference
Controller LCD display is off.	Low or no battery voltage	Check controller connections. Check DC power to the RDC2 controller. Check generator set battery connections and condition. Check utility power connection to the generator set terminal block (power for battery charging).	W/D, Section 7
Controller display back light is off.	Back light turns off after about 1 minute with no activity	Back light will turn on when a button is pressed or the generator set starts.	—
Loss of communication to accessory modules.	Bad connections	Check wiring and connections. Verify that cable size and length of run comply with the instructions in the Installation manual.	Generator set Installation Manual or accessory module documentation.
	Low or no battery voltage	Check generator set battery connections and condition. See "Low or no battery voltage" above.	—
Load management device relays do not operate (if equipped).	Bad connections	Check wiring and connections. Verify that cable size and length of run comply with specifications.	Generator set Installation Manual or load management device documentation.
	Low or no battery voltage	Check generator set battery connections and condition. See "Low or no battery voltage" above.	—
Date is flashing.	Controller power was disconnected and then reconnected	Check battery connections. Check controller connections. Check utility power connection to the generator set terminal block. Reset the time, date, and exercise schedule.	W/D, Section 7 Generator set O/M

Figure 4-6 RDC2 Controller Troubleshooting

Notes

Section 5 Component Testing and Adjustment

5.1 Introduction

The procedures in this section cover the testing and adjustment of components on the generator set. Use these procedures in conjunction to the troubleshooting in **Section 4** to verify that components function properly and to locate the source of problems.

Note: Some procedures may require the disassembly of the enclosure or alternator to access the components. See **Section 6** for disassembly procedures.

5.2 Theory of Operation

The generator set utilizes a rotating-field alternator to produce AC voltage. See Figure 5-1. Refer to Section 7 for the complete generator set schematics.

When the controller receives a start signal, it energizes leads FP and 71. FP energizes the rotor field and lead 71 energizes the crank relay P10. The field current generates a magnetic field that produces AC voltage when it rotates. The controller monitors this AC voltage to determine the engine speed. When the controller senses cranking speed, run relay P11 is energized and the engine is permitted to start. When the engine speed reaches 1000 RPM for the 8RESV or 750 RPM for the 10/12RESV, the alternator produces sufficient voltage to self-excite. The controller drops power to lead 71, ending the start sequence. (See Section 4 for a step-by-step engine start sequence.)

When self-excited, the alternator field is energized by voltage produced in the auxiliary windings, which are designed solely to provide current to the alternator field. This current is controlled by the generator controller to maintain output voltage at the generator's rated level (more field current is required as the load on the generator increases).

Note: The controller does not excite the field during the warmup or cooldown portion of the cycle exercise. The field is also disabled during cooldown and fault cooldown (occurs after certain faults prior to shutting down).

The controller monitors the generator output voltage through leads 11 and 44. It receives a speed signal and power for exciting the field from the auxiliary windings 55 and 66 and supplies current to the alternator field through outputs FP and FN.

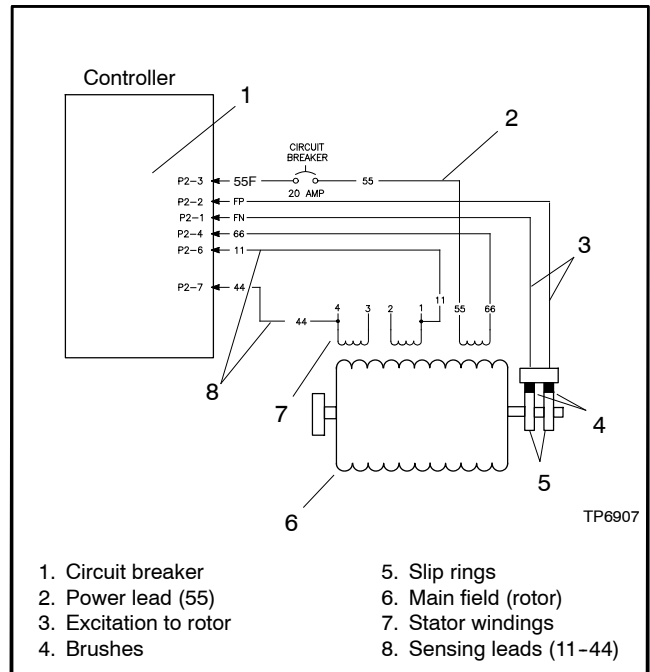
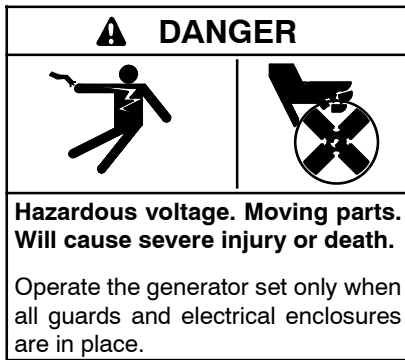

Figure 5-1 Single-Phase Generator Schematic

5.3 Alternator Excitation



Servicing the generator set when it is operating. Exposed moving parts will cause severe injury or death. Keep hands, feet, hair, clothing, and test leads away from the belts and pulleys when the generator set is running. Replace guards, screens, and covers before operating the generator set.

Testing live electrical circuits. Hazardous voltage or current will cause severe injury or death. Have trained and qualified personnel take diagnostic measurements of live circuits. Use adequately rated test equipment with electrically insulated probes and follow the instructions of the test equipment manufacturer when performing voltage tests. Observe the following precautions when performing voltage tests: (1) Remove all jewelry. (2) Stand on a dry, approved electrically insulated mat. (3) Do not touch the enclosure or components inside the enclosure. (4) Be prepared for the system to operate automatically. (600 volts and under)

Short circuits. Hazardous voltage/current will cause severe injury or death. Short circuits can cause bodily injury and/or equipment damage. Do not contact electrical connections with tools or jewelry while making adjustments or repairs. Remove all jewelry before servicing the equipment.

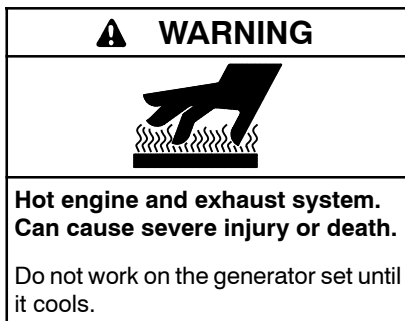

Servicing the alternator. Hot parts can cause severe injury or death. Avoid touching the alternator field or exciter armature. When shorted, the alternator field and exciter armature become hot enough to cause severe burns.

5.3.1 No to Low Voltage Operation

This section covers the operation of the alternator excitation and troubleshooting information for low or no voltage output.

Before beginning the test procedures, read all safety precautions at the beginning of this manual. Many of the test procedures include additional safety precautions.

After crank disconnect, controller will disengage the flash relay when the AC output of the generator reaches 1/4 of the output voltage. At this level, the output on the auxiliary windings should have reached a level sufficient to self-excite the alternator rotor field. If the output voltage does not exceed 1/3 of rated voltage, the generator is only producing voltage using the flash relay. To further isolate the cause of this failure:

1. Check the condition of the auxiliary winding circuit breaker. The circuit breaker is located in the connection area of the junction box. If this breaker is open, the auxiliary winding current will not be able to reach the field and the field will only be supplied by the flash relay. If the breaker is tripped, stop the generator, disconnect P2 and verify no continuity between ground and each of 55, 66, FP, FN.

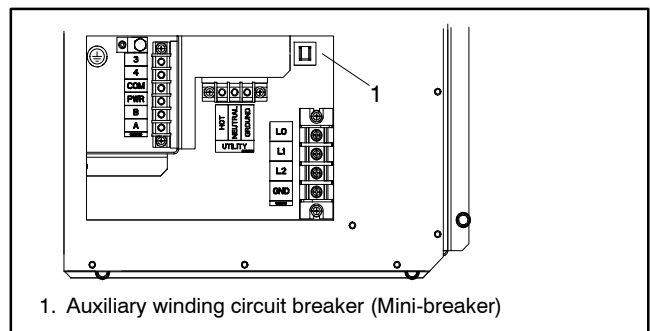

Figure 5-2 Connection Area (cover removed)

2. Verify the connections for 55, 55F and 66 per Figure 5-1.
3. Reconnect P2, start the generator and check for voltage between 55 and 66. This voltage should exceed 30 Volts AC when the AC output voltage is above 60 Volts AC. If the voltage does not exceed 30 VAC, stop the generator and complete the rotor and stator checks in Sections 5.4 and 5.5.
4. Check DC voltage between FP and FN. If this voltage is above 20 VDC, stop the generator and complete the rotor and stator checks in Sections 5.4 and 5.5.
5. If the auxiliary winding voltage exceeds 30 VAC and the field voltage does not exceed 20 VDC, replace the generator controller.

5.3.2 Erratic Voltage Regulation

Dramatic variations in the alternator voltage (more than 5 VAC) while the generator is operating at a steady load may cause flicker. Connect a flicker lamp to the generator output to determine if the generator is producing flicker. If flicker is observed, it can be caused by any of the following:

- Engine speed fluctuation. Refer to Sections 5.10 and 5.11 for troubleshooting.
- Alternator fault. Refer to Sections 5.4 and 5.5 for troubleshooting.
- Outer loop gain too high. Refer to Section 5.9.
- Internal controller stability circuit failure, indicated by excessive throttle movement, excessive voltage fluctuation, and dramatic flicker.

5.3.3 Separate Excitation

Use the following procedure to separately excite the generator using an external voltage source (a 12-volt automotive battery).

Separately exciting the generator can identify faulty voltage regulation by the controller or reveal a running fault in the rotor and/or stator. An external power source duplicates the role of the voltage regulator and excites the generator field (rotor). A generator component that appears to be in good condition while stationary may exhibit a running fault (open or short circuit) while moving. Centrifugal forces acting on the windings during rotation may cause a broken circuit to open. Increasing temperatures can cause the insulation to break down, resulting in a running fault. If this test shows that the rotor and stator are in good condition, test the voltage regulation using the tests in Section 5.8.

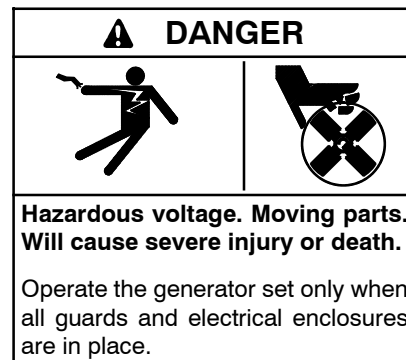

Testing live electrical circuits. Hazardous voltage or current will cause severe injury or death. Have trained and qualified personnel take diagnostic measurements of live circuits. Use adequately rated test equipment with electrically insulated probes and follow the instructions of the test equipment manufacturer when performing voltage tests. Observe the following precautions when performing voltage tests: (1) Remove all jewelry. (2) Stand on a dry, approved electrically insulated mat. (3) Do not touch the enclosure or components inside the enclosure. (4) Be prepared for the system to operate automatically.
(600 volts and under)

Grounding electrical equipment. Hazardous voltage will cause severe injury or death. Electrocutation is possible whenever electricity is present. Ensure you comply with all applicable codes and standards. Electrically ground the generator set, transfer switch, and related equipment and electrical circuits. Turn off the main circuit breakers of all power sources before servicing the equipment. Never contact electrical leads or appliances when standing in water or on wet ground because these conditions increase the risk of electrocution.

Short circuits. Hazardous voltage/current will cause severe injury or death. Short circuits can cause bodily injury and/or equipment damage. Do not contact electrical connections with tools or jewelry while making adjustments or repairs. Remove all jewelry before servicing the equipment.

Separate Excitation Procedure

Perform the following procedure to use an external voltage source to excite the main field (rotor).

1. Disconnect the black FN and FP leads from the alternator at the brush holder terminals.
2. Connect a DC ammeter, 10-amp fuse, and a 12-volt automotive battery to the positive (FP) and negative (FN) brush leads as shown in Figure 5-3. Note and record the ammeter reading.

Note: The approximate ammeter reading should be the battery voltage divided by the specified rotor resistance. See Section 1, Specifications, for specified rotor resistance values.

Example:

$$\frac{12 \text{ volts (battery voltage)}}{4 \text{ ohms (rotor resistance)}} = 3 \text{ amps (rotor current)}$$

3. Start the engine and check that the ammeter reading remains stable. An increasing meter reading indicates a shorted rotor. A meter reading decreasing to zero or an unstable reading suggests a running open. Refer to Section 5.5, Main Field (Rotor), to test the rotor. If the ammeter reading is stable, proceed to step 4.
4. Check for AC output across the stator leads; see Section 5.4, Stator. Compare the readings to the AC output values shown in Section 1, Specifications. If the readings vary considerably, a faulty stator is likely. Refer to Section 5.4, Stator, for further information.
5. If this test shows that the rotor and stator are in good condition, check the wiring and fuses. Check the controller settings and connections. See Section 3, Controller.

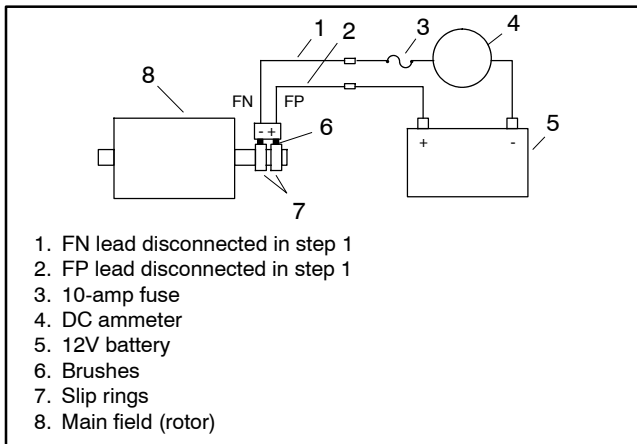
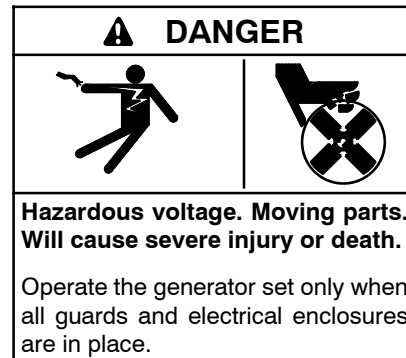

Figure 5-3 Separate Excitation Connections

5.4 Stator

The stator contains a series of coils of wire laid in a laminated steel frame. The stator leads supply AC voltage to the load and voltage regulator. Before testing the stator, inspect it for heat discoloration and visible damage to housing lead wires, exposed coil windings, and exposed areas of frame laminations. Be sure the stator is securely fastened to the stator housing.

Note: Disconnect all stator leads before performing all stator tests.



High voltage test. Hazardous voltage will cause severe injury or death. Follow the instructions of the test equipment manufacturer when performing high-voltage tests on the rotor or stator. An improper test procedure can damage equipment or lead to generator set failure.

Short circuits. Hazardous voltage/current will cause severe injury or death. Short circuits can cause bodily injury and/or equipment damage. Do not contact electrical connections with tools or jewelry while making adjustments or repairs. Remove all jewelry before servicing the equipment.

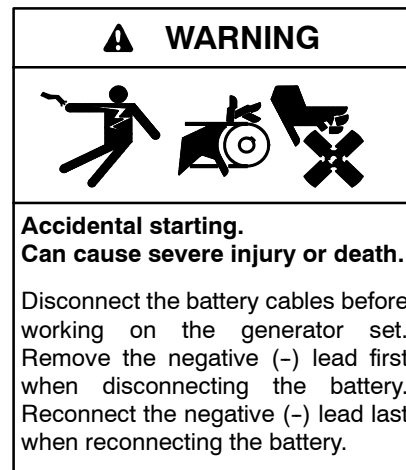

Disabling the generator set. Accidental starting can cause severe injury or death. Before working on the generator set or equipment connected to the set, disable the generator set as follows: (1) Press the generator set off/reset button to shut down the generator set. (2) Disconnect the power to the battery charger, if equipped. (3) Remove the battery cables, negative (-) lead first. Reconnect the negative (-) lead last when reconnecting the battery. Follow these precautions to prevent the starting of the generator set by the remote start/stop switch.

Stator Continuity and Resistance Tests

1. Press the OFF button on the controller to turn off the generator set.
2. Disconnect utility power to the generator set.
3. Disconnect the generator set engine starting battery, negative (-) lead first.
4. Disconnect all stator leads before performing all stator tests.
5. To check for stator continuity, set the ohmmeter on R x 1 scale. First set the ohmmeter zero by holding the red and black meter leads together and setting the ohmmeter reading to zero. Then check the stator continuity by connecting the meter leads to the stator leads as shown in Figure 5-4.

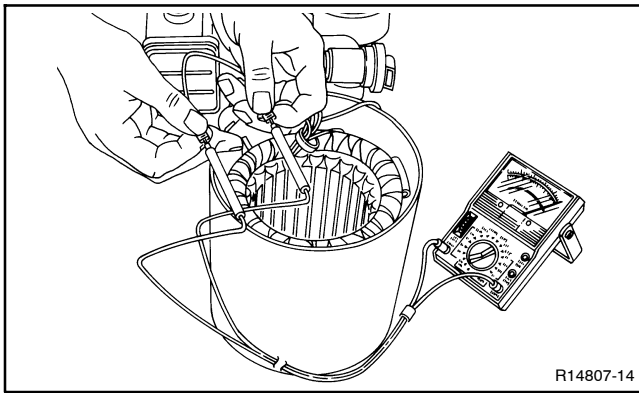

Figure 5-4 Testing Stator Windings

Note: For single-phase models, leads 1, 2, 3, and 4 are the generator output leads. Leads 11, 44, 55, and 66 are the controller sensing and supply leads. Refer to the schematic in Figure 5-5 when performing the following steps.

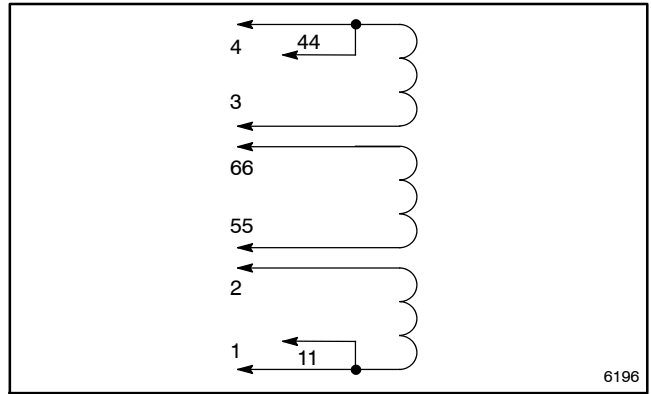

Figure 5-5 Single-Phase Alternator Stator Leads

6. Contact the ohmmeter leads and readjust the ohmmeter to read zero ohms.
7. Check the cold resistance of the stator windings by connecting the meter leads to stator leads 1-2, 3-4, and 55-66. See Section 1.5, Alternator Specifications, for stator winding resistances. Most ohmmeters do not provide accurate readings below 1 ohm. Low resistance readings (continuity) and no evidence of shorted windings (heat discoloration) indicate a stator in good condition. See Figure 5-6.

Leads	Continuity
1 and 2	Yes
1 and 11	
2 and 11	
3 and 4	
3 and 44	
4 and 44	
55 and 66	No
1 and 3, 4, 44, 55, or 66	
2 and 3, 4, 44, 55, or 66	
3 and 1, 2, 11, 55, or 66	
4 and 1, 2, 11, 55, or 66	
Any stator lead and ground on stator housing or frame laminations	

Figure 5-6 Continuity Test Results on a Good Stator (single-phase)

8. If the resistance test proves inconclusive, use a megohmmeter to test the stator as described in the next step.

Note: Because ohmmeter accuracy varies, resistance readings are approximate readings. Take readings of the rotor and stator at room temperature.

Note: Make sure that all stator leads are disconnected before running the megohmmeter test.

9. Use a megohmmeter to determine whether the stator is shorted to ground.

a. Apply 500 volts DC to any stator lead and the stator frame. Perform the megohmmeter test following the instructions of the megohmmeter manufacturer.

b. Repeat the test on the other stator leads until each coil is tested.

Note: A reading of approximately 500 kOhms (1/2 megohm) and higher indicates a good stator.

c. Repair or replace the stator if any reading is less than approximately 500 kOhms. A reading of less than 500 kOhms indicates deterioration of the winding insulation and possible current flow to ground.

5.5 Main Field (Rotor)

The two-pole rotor creates the magnetic field needed to produce alternating current in the stator windings. Before testing, inspect the rotor for visible damage to pole shoes, insulation, exposed coil windings, and slip ring surfaces. Rotate the bearing to check for wear, heat discoloration, or noise.

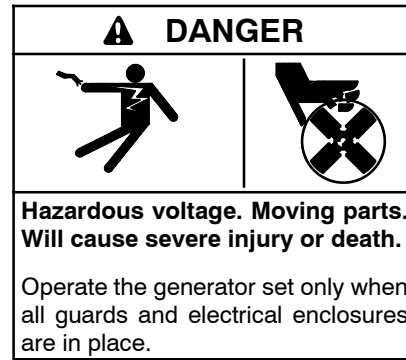

High voltage test. Hazardous voltage will cause severe injury or death. Follow the instructions of the test equipment manufacturer when performing high-voltage tests on the rotor or stator. An improper test procedure can damage equipment or lead to generator set failure.

Grounding electrical equipment. Hazardous voltage will cause severe injury or death. Electrocutation is possible whenever electricity is present. Ensure you comply with all applicable codes and standards. Electrically ground the generator set, transfer switch, and related equipment and electrical circuits. Turn off the main circuit breakers of all power sources before servicing the equipment. Never contact electrical leads or appliances when standing in water or on wet ground because these conditions increase the risk of electrocution.

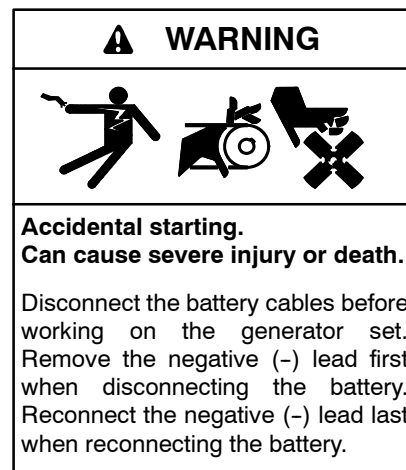

Disabling the generator set. Accidental starting can cause severe injury or death. Before working on the generator set or equipment connected to the set, disable the generator set as follows: (1) Press the generator set off/reset button to shut down the generator set. (2) Disconnect the power to the battery charger, if equipped. (3) Remove the battery cables, negative (-) lead first. Reconnect the negative (-) lead last when reconnecting the battery. Follow these precautions to prevent the starting of the generator set by the remote start/stop switch.

Rotor Test Procedure

1. Press the OFF button on the controller to turn off the generator set.
2. Disconnect utility power to the generator set.
3. Disconnect the generator set engine starting battery, negative (-) lead first.
4. Check the rotor for continuity and resistance. While performing ohmmeter tests, remove the two brush holder mounting screws. raise the brushes from the slip rings, and then move and secure the brushes out of the way. Measure the rotor resistance (ohms) between the two slip rings; see Figure 5-7. See Section 1.5 for rotor resistance readings. If the resistance readings are low, perform a megohmmeter test on rotor as described in the next step.

Note: Because ohmmeter accuracy varies, resistance readings are approximate. Take readings at room temperature.

5. Perform a megohmmeter test to determine whether the rotor is shorted to ground.
 - a. Remove the two brush holder mounting screws. Raise the brushes and then move and secure the brushes out of the way.
 - b. Using a megohmmeter, apply 500 volts DC to one rotor slip ring and the rotor poles or shaft.

Follow the instructions of the megohmmeter manufacturer when performing this test.

Note: A reading of approximately 500 kOhms (1/2 megohm) or higher indicates a good rotor.

- c. Repair or replace the rotor if the reading is less than approximately 500 kOhms. A reading of less than 500 kOhms indicates deterioration of the winding insulation and possible current flow to ground.
- d. Following the test, remove the retainer wire from the brush holder and check the brush positions on the slip rings. See Section 5.7, Brushes.

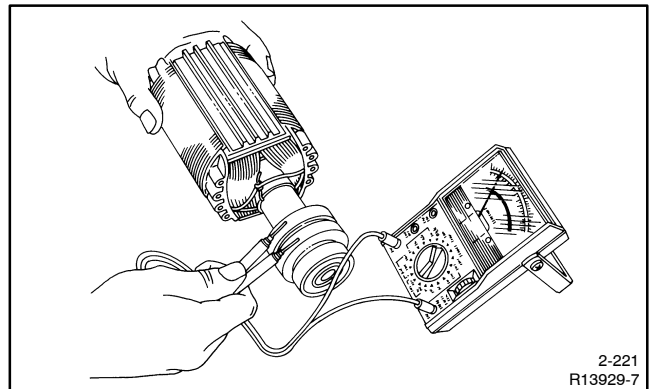

Figure 5-7 Rotor Resistance Check

5.6 Slip Rings

Slip rings acquire a glossy brown finish in normal operation. Do not attempt to maintain a bright, newly-machined appearance on the slip rings. Cleaning with a dry, lint-free cloth is usually sufficient. Use very fine sandpaper (#00) and apply light pressure to remove roughness. Do not use emery or carborundum paper or cloth. Clean all carbon dust from the generator after sanding the slip rings. If the rings are black or pitted, remove the rotor and use a lathe to remove some of the slip ring surface material.

5.7 Brushes

The brushes transfer current to the slip rings. The brushes should last the life of the generator. However, abrasive dust on the slip ring can shorten the life of the brushes.

Excessive arcing at the brushes could damage the controller. Weak springs, damaged slip rings, sticking brushes, a loose brush holder, or poor brush contact causes arcing.

The brush holder assembly is illustrated in Figure 5-9. The brushes must be free to move within the holder and be held in contact with the slip rings by the springs. When correctly positioned, spring pressure on the brush surface causes the brush to wear evenly. The entire brush must ride on the ring or arcing occurs and causes burned rings or voltage regulator failure. Figure 5-8 shows the correct positioning of the brushes. Add or remove shims as necessary to center the brushes on the slip rings. Replace the brushes if they show uneven wear or are worn to one half their original length.

Check the resistance through the brushes. Resistance through the brushes should be low, 0.1–0.2 ohms without meter lead resistance.

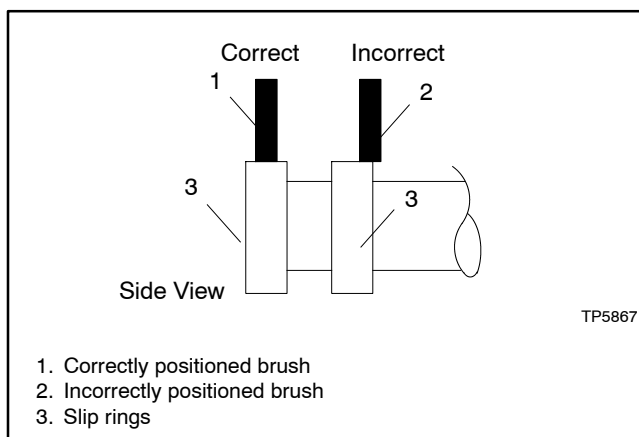

Figure 5-8 Brush Position

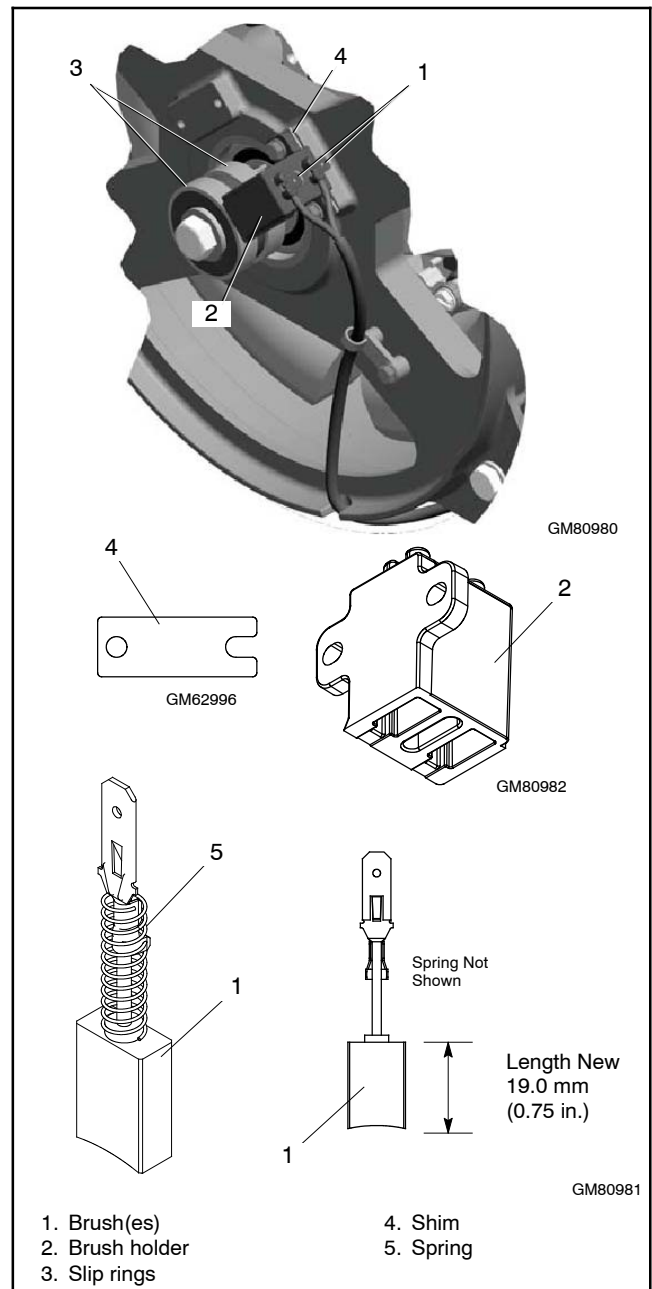

Figure 5-9 Brush Assembly

5.8 Voltage Connections

Single-phase generator sets are available from the factory connected for 120/240 volt 60 Hz. See Figure 5-10 for the factory connections. The generator sets covered in this document are not reconnectable.

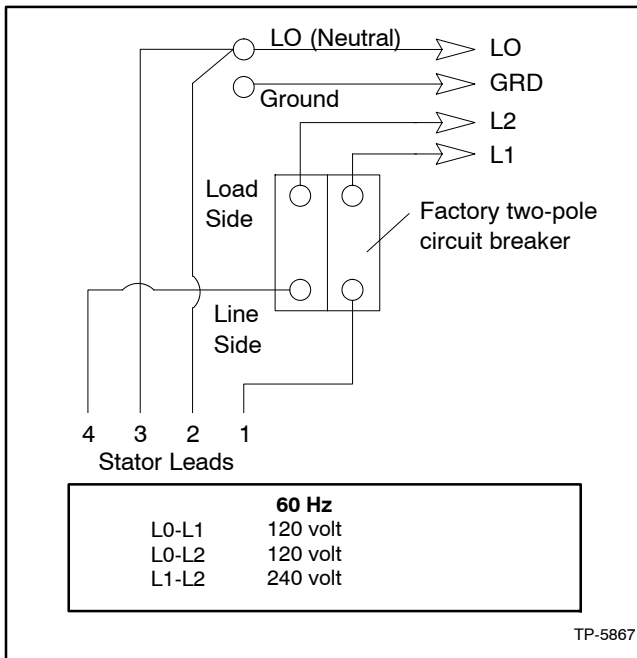
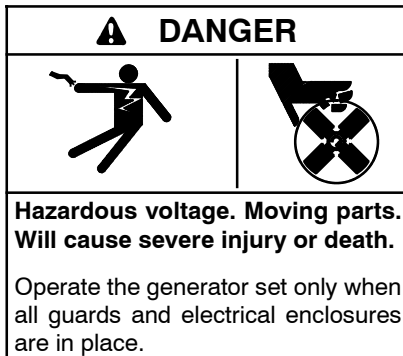

Figure 5-10 120/240 Volt, 3-Wire Configurations

5.9 Voltage Adjustments



Testing live electrical circuits. Hazardous voltage or current will cause severe injury or death. Have trained and qualified personnel take diagnostic measurements of live circuits. Use adequately rated test equipment with electrically insulated probes and follow the instructions of the test equipment manufacturer when performing voltage tests. Observe the following precautions when performing voltage tests: (1) Remove all jewelry. (2) Stand on a dry, approved electrically insulated mat. (3) Do not touch the enclosure or components inside the enclosure. (4) Be prepared for the system to operate automatically. (600 volts and under)

Short circuits. Hazardous voltage/current will cause severe injury or death. Short circuits can cause bodily injury and/or equipment damage. Do not contact electrical connections with tools or jewelry while making adjustments or repairs. Remove all jewelry before servicing the equipment.

Note: See Section 3.7 for voltage calibration instructions.

Voltage Adjustments Using SiteTech

The SiteTech parameters used to adjust the voltage are shown in Figure 5-11.

SiteTech Group	Parameter
Genset System Configuration	Genset System Voltage
Voltage Regulator	Average Voltage Adjustment
	Volts per Hertz Slope
	Volts per Hertz Cut-in Frequency
	Voltage Regulator Gain

Figure 5-11 SiteTech Parameters for Voltage

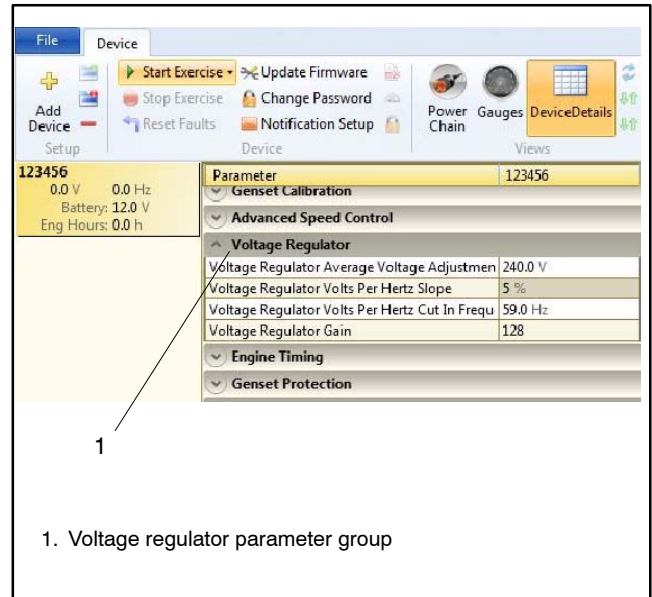

Figure 5-12 Voltage Regulator Parameter Group in SiteTech

5.9.1 Voltage Regulator Average Voltage Adjustment

Voltage regulation is performed by the controller. The controller monitors generator output voltage and adjusts the excitation current to the rotor.

Excitation current control is performed by the patented Kohler Hybrid Voltage Regulator. This regulator consists of a fast-reacting analog inner loop and a slower digital outer loop. The inner loop regulates the average output voltage to a setpoint which is controlled by the outer loop, allowing the voltage to recover very quickly during transient conditions. The outer loop measures the RMS magnitude of the voltage and adjusts the setpoint for the inner loop until the RMS

voltage amplitude matches the Voltage Regulator Average Voltage Adjustment setpoint.

The hybrid regulator should require no voltage adjustment, as it regulates the RMS output voltage to the configured output voltage. The Voltage Regulator Average Voltage Adjustment setpoint may require alteration to more closely match the utility voltage at a particular location or to compensate for voltage drop on wiring between the generator and the ATS.

The Voltage Regulator Average Voltage Adjustment can be adjusted from the Voltage Regulator menu on the RDC2 controller, or adjusted using SiteTech. See Figure 5-11 and Figure 5-13.

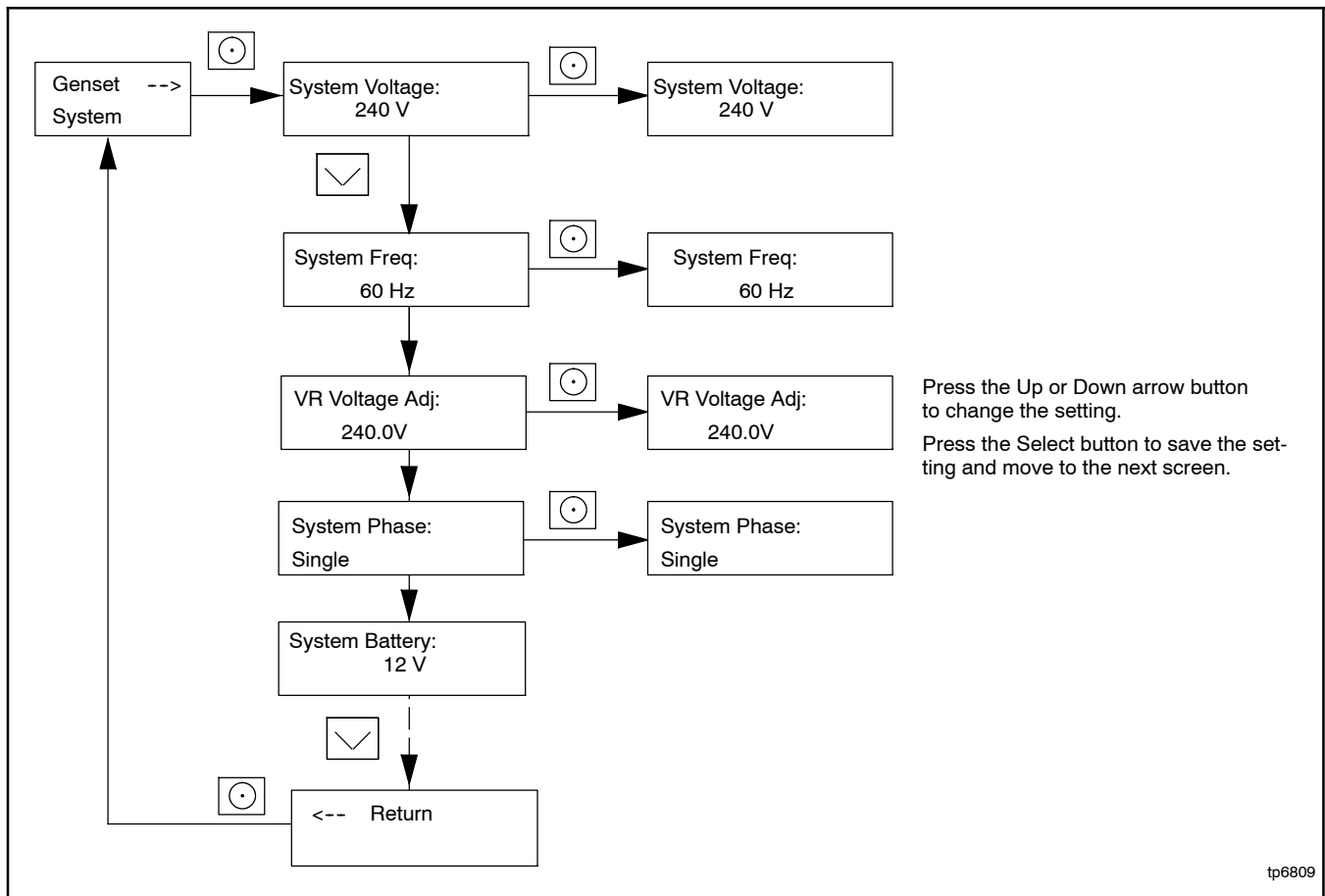

Figure 5-13 Voltage Regulator Voltage Adjustment Using RDC2 Controller Menus and Keypad

5.9.2 Volts/Hz Slope and Cut-In Frequency

The Volts/Hz setting for the voltage regulator performs the following functions on the generator:

- Serves as a method for unloading the engine to allow recovery during a sharp increase in load
- Serves as a means of protection for the alternator to avoid saturating the field (rotor heating) at low frequencies

The slope and cut-in frequency of the volts/Hz curve are set at the factory to allow the generator to meet factory performance standards. They should not be adjusted except under unique circumstances and under direction from a Kohler factory representative.

If the slope of the Volts/Hz curve is set too low, the engine will not be unloaded quickly enough to recover from a quick load increase. If the slope is set too high, the voltage will dip dramatically with a quick load increase, which will cause temporary brownouts.

The cut-in frequency is typically set to 1 Hz below system frequency so that normally small frequency variations do not cause the voltage to vary. Setting the cut-in frequency further from rated frequency may adversely affect the generator’s ability to recover frequency after a sharp load increase.

See Figure 5-14 for an illustration of the volts/Hz curves for 60 Hz.

5.9.3 Voltage Regulator Gain

The gain of the inner loop of the hybrid regulator is set at the factory and is not adjustable in the field. The Voltage Regulator Gain listed in SiteTech is for the outer loop. The outer loop is responsible for correcting the setpoint to the inner loop to ensure that the generator output is regulated to the RMS regulator setpoint. The outer loop thus corrects for wave-shape distortion, temperature variations in the inner loop circuitry, inter-board metering variations, etc. Typically the outer loop only adjusts the setpoint to the inner loop on initial startup (battery is first plugged in) and after calibration has changed.

At a gain setting of 1, it will take 128 seconds to adjust the voltage output 1%. At a gain setting of 255, the voltage adjustment rate is related to the difference between the target voltage and the measured voltage, but could vary up to 3.1% per second.

At lower gains, the voltage may reach the target value very slowly, but the chance of overshoot from the two controller loops fighting is minimal. At higher gains, there is a chance that the outer loop will change the setpoint faster than the inner loop can accommodate, resulting in unstable output voltage. This may show up as slight flicker on a light bulb.

Note: The RMS correction outer loop is not active when the controller is in Volts/Hz mode; the last known correction factor, or inner loop setpoint, is used.

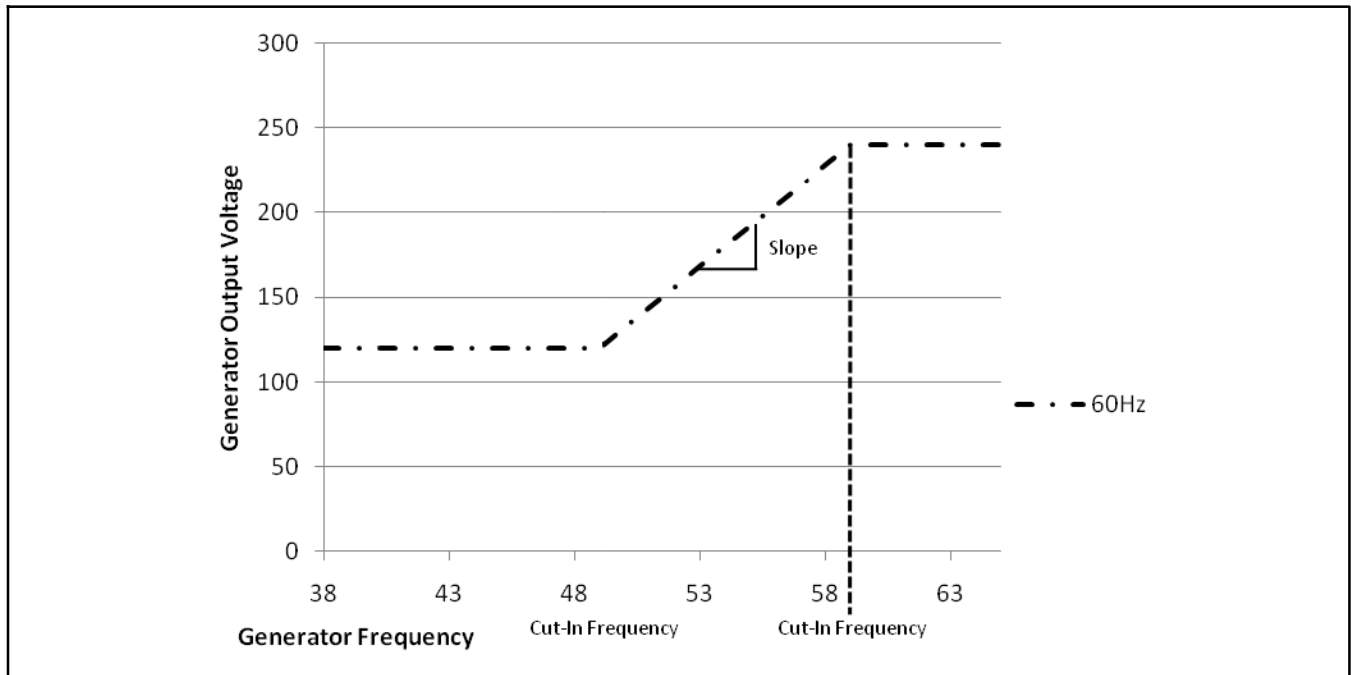

Figure 5-14 Volts/Hz Curves

5.10 Governor System

The governor system consists of an electromechanical stepper motor (actuator) and an engine speed detection/feedback circuit. The RDC2 or DC2 controller controls the governor system operation. See Section 7, Wiring Diagrams, for the governor connections.

5.10.1 Operation

The frequency of the alternator output is determined by the speed of the engine. A two-pole alternator is driven at 3600 rpm to provide 60 Hertz. The engine speed is maintained by an electronic governor system that consists of an embedded controller and electric actuator (stepper motor).

The governor system is controlled by the generator set controller. The controller provides regulated power to the bidirectional stepper motor actuator, which is linked to the carburetor throttle arm.

The engine runs at a reduced speed during the warmup and cooldown idle period of the cycle exercise. During this time, the rotor field is not energized and the generator will not produce voltage. When not producing voltage, the generator will not be subject to large changes in engine loading, so the governor response is dramatically slowed to decrease throttle linkage wear and fuel consumption. The response is also slowed during cooldown and fault cooldown for the same reason.

The engine speed adjustment setting in SiteTech allows adjustment of the engine speed for testing purposes. See Section 5.11.2. If the engine is hunting or surging, do not adjust the engine speed. Test the governor operation as described in Sections 5.10.3 and 5.10.4. Then adjust the governor gain to stabilize the engine operation if necessary before adjusting the speed. See Section 5.11.1.

5.10.2 Initial Checks

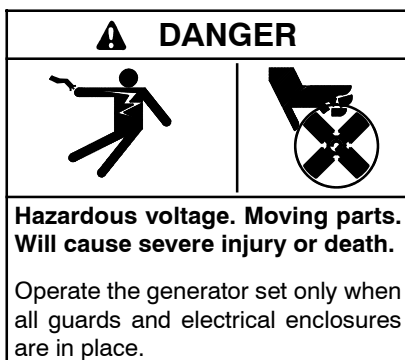

Servicing the generator set when it is operating. Exposed moving parts will cause severe injury or death. Keep hands, feet, hair, clothing, and test leads away from the belts and pulleys when the generator set is running. Replace guards, screens, and covers before operating the generator set.

The factory sets the electronic governor. Under normal circumstances the electronic governor requires no further adjustment. Verify that the governor stepper motor moves smoothly and steadily during operation. If the engine operates erratically, check the following connections and conditions *before* adjusting the governor.

- Verify that the electrical connections are clean and tight.
- Verify that the battery connections are clean and tight.
- Check for a loose or worn stepper motor/throttle shaft coupling. Replace the shaft and bushing every 500 hours of engine operation.
- Check the carburetor for dirt, grime, or misadjustment. Check for a loose mixer assembly.
- Check the idle-adjustment screw. The screw should not prevent the throttle plate from closing completely.
- Check the throttle linkage for any binding, dirt, damage, or other visible problems.
- Observe the stepper motor operation. The stepper motor should open the throttle while cranking, and pull back after speed feedback is detected.
- Check for electronic governor faults. The fuel shutoff solenoid deenergizes and the generator set shuts down under the following conditions:
 - Closed throttle
 - Engine overspeed
 - Broken fuel shutoff solenoid lead
 - Broken stepper motor leads (erratic performance)
 - Failed actuator linkage (erratic performance)
- Check the fuel supply pressure and the fuel supply system for leaks, blockages, and/or failed system components (regulators, valves, etc.). See Section 5.13, Fuel Systems.

5.10.3 Hunting/Surging

Hunting/surging problems thought to be caused by the governor system are more likely to be caused by fuel supply, engine, or carburetor problems. Check engine speed stability using the following procedure before testing the governor.

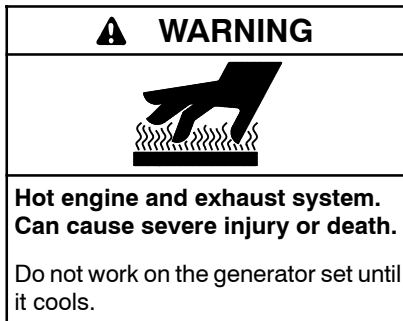

Servicing the exhaust system. Hot parts can cause severe injury or death. Do not touch hot engine parts. The engine and exhaust system components become extremely hot during operation.

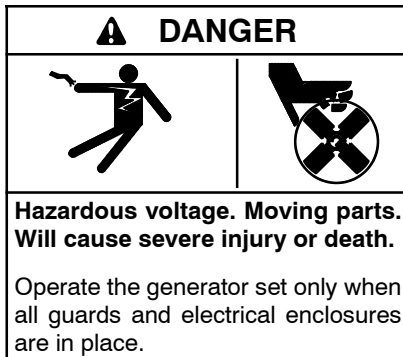

Servicing the generator set when it is operating. Exposed moving parts will cause severe injury or death. Keep hands, feet, hair, clothing, and test leads away from the belts and pulleys when the generator set is running. Replace guards, screens, and covers before operating the generator set.

1. Open the generator set line circuit breaker.
2. Start the generator set.
3. Hold the throttle linkage steady while the engine is running. See Figure 5-15. If the engine runs at a steady speed with no hunting or surging when the throttle is held steady, then the hunting/surging problems during operation are probably caused by the governor. Proceed to Section 5.10.4.
4. Check the linkage between the stepper motor and the carburetor. Replace any worn or damaged components.

5. Verify that the speed control parameters have not been modified. Reset the parameters to the default settings if they have been modified. See Figure 5-18, Controller Settings.
6. If the engine speed hunts or surges while the throttle is held steady, check the carburetor and engine operation. Refer to the engine service manual for engine diagnostic and service information.

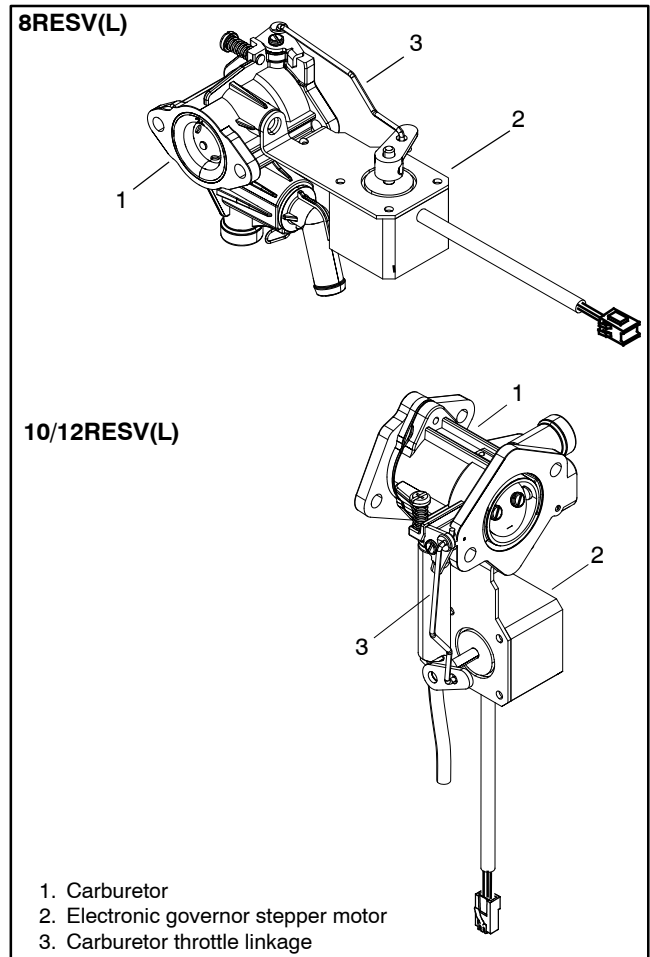
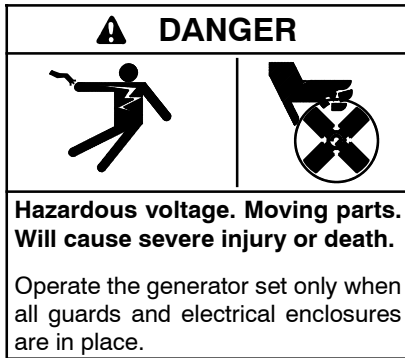

Figure 5-15 Stepper Motor and Carburetor

5.10.4 Governor System Operation Test



Servicing the generator set when it is operating. Exposed moving parts will cause severe injury or death. Keep hands, feet, hair, clothing, and test leads away from the belts and pulleys when the generator set is running. Replace guards, screens, and covers before operating the generator set.

If the engine continues to operate erratically after the previous checks, test the governor system operation using the following procedure. The procedure is summarized in the flowchart in Figure 5-16.

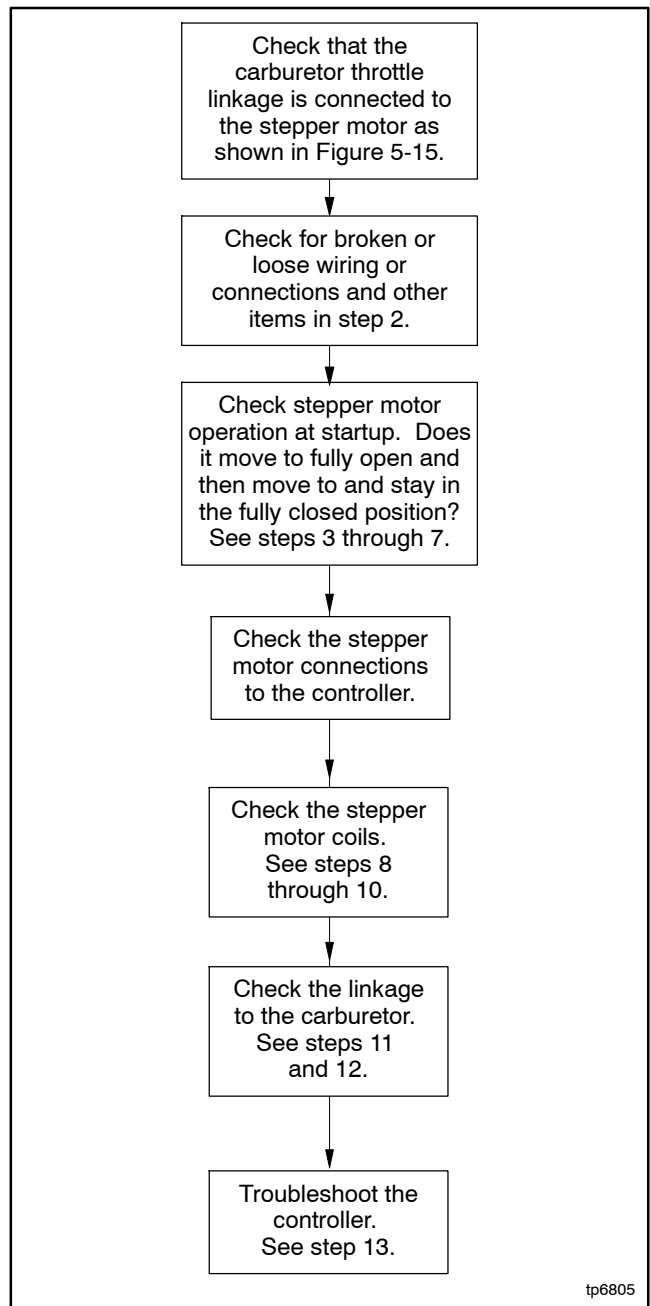

Figure 5-16 Governor System Operation Test Procedure Summary

Governor System Operation Test Procedure

1. Verify that the carburetor throttle linkage is connected to the stepper motor as shown in Figure 5-15.
2. Look for broken or loose wiring or plug connections if the stepper motor moves erratically. Check the condition of the throttle linkage, and verify that the throttle plate closes completely.

Check the operation of the stepper motor at startup.

3. Before starting the generator, move the throttle to the fully closed position. Press the RUN button to initiate the start sequence.
4. If the throttle stays in the fully closed position, and the controller shows a Locked Rotor fault, verify that the generator set model is set to 8RESV, 10RESV, or 12RESV. Then check and verify the alternator connections, functionality, and operation. See the wiring diagrams and Sections 5.3 through 5.7 of this document.
5. If the throttle moves to the fully open position and remains fully open, and the controller shuts down the generator for an overspeed or overfrequency fault, verify that the generator set model is set to 8RESV, 10RESV, or 12RESV. Then check the throttle linkage and stepper motor connections and operation. Go to step 8 of this procedure.
6. If the throttle moves to the fully open position and remains fully open, the engine goes to a high speed condition, and the controller does not shut down the generator, verify that the generator set model is set to 8RESV, 10RESV, or 12RESV. Then check and verify the alternator connections, functionality, and operation. See the wiring diagrams and Sections 5.3 through 5.7 of this document.
7. If the throttle moves to the fully open position and then moves toward the closed position, but the engine speed is erratic or behaves poorly, check the throttle linkage and stepper motor connections and operation. See stepper motor troubleshooting starting with step 8 of this procedure. Also check that the engine speed control parameters are set to the default settings (Engine Speed Governor and Advanced Speed Control parameters in SiteTech).

Check the stepper motor, carburetor, and linkage.

8. To test controller's governing function, open the generator set circuit breaker, disconnect the engine starting battery, and shut off the fuel supply.
9. Disconnect the stepper motor plug P6 to access the stepper motor terminals.
10. Check the stepper motor coil resistance across pins 2 and 3 and across pins 1 and 4. Only two stepper motor leads of each coil group are used (BLK-YEL and RED-WHT). See Figure 5-17. The resistance per half coil is 38.5 ohms. If one of the coils has a significantly higher resistance or is shorted, replace the stepper motor.

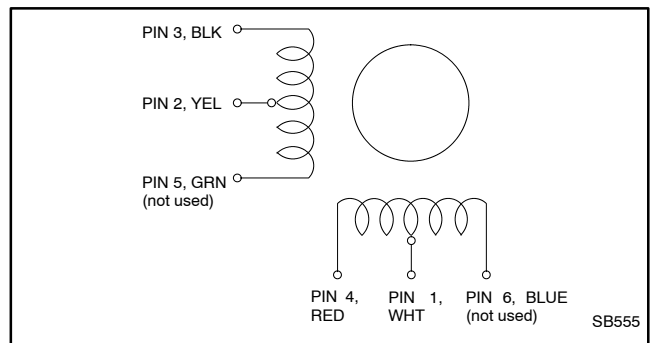
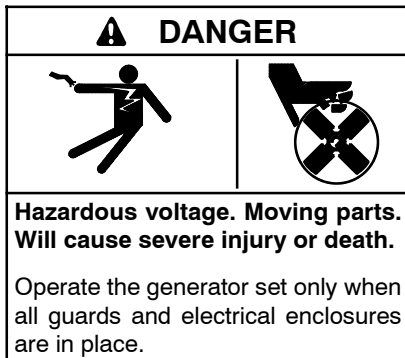

Figure 5-17 Actuator Coil Group

11. Inspect the linkage and the bushings between the stepper motor and the carburetor for damage. Replace as necessary.
12. Disconnect the linkage between the stepper motor and the carburetor. Verify free, full range of motion for the stepper motor and the carburetor throttle plate. Replace as necessary.
13. If there is power and a good ground connection to the controller and the stepper motor, and the carburetor and linkage pass the checks of steps 10 through 12, the problem is with the controller. Check controller connections, wiring, and settings. Refer to the troubleshooting procedures in Section 4.

5.11 Frequency Adjustment



Servicing the generator set when it is operating. Exposed moving parts will cause severe injury or death. Keep hands, feet, hair, clothing, and test leads away from the belts and pulleys when the generator set is running. Replace guards, screens, and covers before operating the generator set.

The engine speed determines the generator output frequency; 60 Hz units operate at 3600 RPM. When the system frequency setting on the controller is changed, the engine run speed will automatically update.

Set the system frequency to 60 Hz before adjusting the engine speed. The system frequency can be adjusted using the controller keypad on the RDC2 controller or using a personal computer running Kohler® SiteTech™ software. The DC2 controller must be adjusted using SiteTech™ software.

Frequency Adjustment Procedure

1. Use the RDC2 controller's Genset System menu or use SiteTech to set the system frequency to 60 Hz.

Note: Although the RDC2 System Frequency menu scrolls through numbers from 51-59, the only available settings are 50 and 60 Hz.

2. Open the generator set line circuit breaker.
3. Attach a frequency meter to the AC output leads.
4. Start and run the generator set. Verify that the output frequency matches the desired system frequency.
5. Check stability with the generator set running and with no load applied. If the generator set speed is unstable, hunts, or surges, use SiteTech to verify that the engine speed control parameters are set to the default settings (Engine Speed Governor settings in SiteTech).

Note: Hunting/surging problems thought to be caused by the governor are more likely to be caused by fuel supply, engine or carburetor problems. If the generator set speed is unstable, hunts, or surges, check for the cause using the procedure in Section 5.10.3 before proceeding.

6. Apply rated load to the generator set and observe the frequency reading. The no load and full load frequency should not vary more than 0.4 Hz from the rated generator frequency.
 - a. If the frequency varies significantly more than 0.4 Hz from the system frequency, check that the carburetor throttle plate opens completely without sticking and check the carburetor adjustment.
 - b. If the frequency is steady but running below rated frequency, verify that the throttle is completely open. If so, reduce the load on the engine until the frequency recovers.
7. Check for hunting and surging at full load. If the generator speed is unstable, hunts, or surges, the governor gain may require adjustment. See Section 5.11.1, Engine Speed Gain adjustment, for instructions to change the governor gain.
8. Remove the load and observe the frequency. The frequency should return to the rated level within a few seconds. If the speed does not recover or the generator controller shuts down for over frequency or overspeed, it may be necessary to adjust the governor gain. See Section 5.11.1.

5.11.1 Engine Speed Gain Adjustment for the Governor

Note: Adjusting the governor gain may cause the generator to operate incorrectly.

Note: Typical governor gain settings are between 35 and 65. Settings outside this range are not recommended for extended use (troubleshooting only).

The governor gain controls how much throttle movement is tied to a given change in the generator speed. Higher gains make the throttle move more aggressively on a speed change, lower gains make the throttle move more slowly.

Using Kohler SiteTech, adjust the Engine Speed Gain Adjustment setting in the Engine Speed Governor group. Change the governor gain setting in small steps (5 or less).

- If the engine is hunting slowly (changes from maximum to minimum speed in more than a second), increase the governor gain.
- If the generator is hunting quickly (maximum to minimum speed several times per second), decrease the gain.
- If changing the gain makes the hunting worse, try changing the gain in the other direction.

5.11.2 Engine Speed Adjustment for Governor

The Engine Speed Adjustment parameter in the Engine Speed Governor group in SiteTech can be adjusted while the generator set is running.

Note: The Engine Speed Adjustment parameter must be left at the default value (50) for the generator to operate at the correct frequency. If this parameter is changed during troubleshooting and testing, make sure to return it to the default setting before disconnecting SiteTech from the generator controller.

The Engine Speed Adjustment setting can be adjusted from 0 to 99 for test purposes. Setting the Engine Speed Adjustment to 0 will make the governor regulate speed to 100 RPM slower than the rated speed. Setting the Engine Speed Adjustment to 99 will make the governor regulate speed to 98 RPM faster than the rated speed setting.

Changing the Engine Speed Adjustment setting will change the engine speed according to the following formula:

$$(\text{System Frequency} \times 60) + ((\text{Setting} - 50) \times 2) = \text{RPM}$$

Examples:

System frequency of 60 Hz, changing the setting to 40:

$$(60 \times 60) + ((40 - 50) \times 2) = 3580 \text{ RPM}$$

5.11.3 Advanced Speed Control

Note: Do not adjust the Advanced Speed Control settings unless instructed to do so by the Kohler Generator Service Department.

The four parameters under Advanced Speed Control also permit adjustment of the governor function, but have the potential of dramatically affecting the load transient performance of the generator. They are set in the factory and are tested to comply with factory performance standards. They should never be changed from the factory settings except under the direction of factory personnel.

SiteTech Group	Parameter	Units	Adjustment Range *	Default Setting
Engine Speed Governor	Engine Speed Adjustment		0 - 99	50
Engine Speed Governor	Engine Speed Gain Adjustment		35-65	50
Genset Personality Profile	Engine Run Speed †	RPM	1000 - 3900	3600
Genset System configuration	Genset System Frequency	Hz	50/60	60.0
* From generator set nameplate. For the 8RESVL, select 8RESV. For the 10RESVL, select 10RESV. For the 12RESVL, select 12RESV.				
† Engine Run Speed is set automatically when the System Frequency is set.				

Figure 5-18 Engine Speed and Frequency Parameters in SiteTech

Parameter	123456
Engine Speed Governor	
Engine Speed Adjustment	50
Engine Speed Gain Adjustment	50
Generator Metering	
Genset Info	
Genset Run Time	
Genset Personality Profile	
ECM Model	No ECM
Maximum Alternator Current	920 A
Engine Number Of Flywheel Teeth	1
Engine Warmed Up Temperature	32 °F
Engine Cooled Down Temperature	79 °F
Engine Crank Disconnect Speed	1000 R/min
Engine Idle Speed	2700 R/min
Engine Run Speed	3600 R/min
Engine Coolant Temperature Protectives Enab	Low Warning
Engine Coolant Temperature Sensor	None
Engine High Coolant Temperature Inhibit Dela	0 s
Engine Low Coolant Temperature Warning De	0 s

Parameter	123456
Genset Personality Profile	
Genset System Configuration	
Genset System Voltage	240.0 V
Genset System Frequency	60.0 Hz
Genset Voltage Phase Connection	Single Phase
Genset Power Rating	8.0 kW
Genset Rated Current	100.0 A
Genset System Battery Voltage	12 V
Prime Power Application	Standby

1. Engine Speed Adjustment
2. Engine Run Speed Setting (changes automatically with Genset System Frequency)
3. Genset System Frequency Setting (50 or 60 Hz)

Figure 5-19 Engine Speed and Frequency Parameters in SiteTech

5.12 Fault Shutdown Tests

Verify the operation of the generator set overspeed, overcrank, and low oil pressure shutdowns by performing the following tests. If these tests are inconclusive, test individual shutdown circuit components (wiring harness, switch, etc.) as described elsewhere in this section.

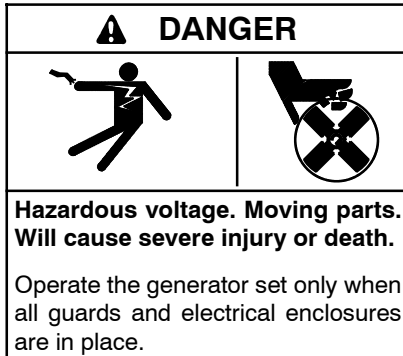

Servicing the generator set when it is operating. Exposed moving parts will cause severe injury or death. Keep hands, feet, hair, clothing, and test leads away from the belts and pulleys when the generator set is running. Replace guards, screens, and covers before operating the generator set.

Short circuits. Hazardous voltage/current will cause severe injury or death. Short circuits can cause bodily injury and/or equipment damage. Do not contact electrical connections with tools or jewelry while making adjustments or repairs. Remove all jewelry before servicing the equipment.

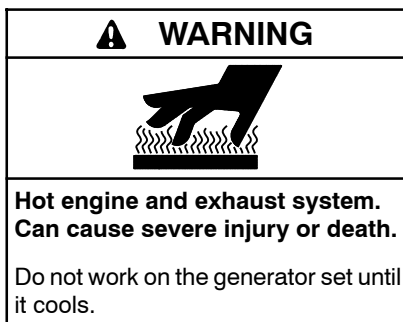

Servicing the exhaust system. Hot parts can cause severe injury or death. Do not touch hot engine parts. The engine and exhaust system components become extremely hot during operation.

5.12.1 Controller Fault Shutdown Functions

Check the operation of the fault functions programmed in the controller by performing the following tests. If the controller does not operate as described, check the controller settings. Also check the controller wiring and connections.

Verify that the controller parameters shown in Figure 5-20 are set correctly for your unit. For RESVL models, select RESV.

Open the generator set output circuit breaker before beginning the test. (See Figure 1-1 for the circuit breaker location.)

Parameter	Setting
Genset Model Number*	8RESV, 10RESV, 12RESV
Genset Serial Number*	From nameplate; see Figure 3-7.
Fuel Type†	Natural Gas or Liquid Propane (LPG)
Phase Connection†	Single Phase
Genset System Voltage†	From nameplate; see Figure 3-7.
Genset System Frequency†	50 or 60 Hz
* In the Generator Set Information menu.	
† In the Genset System menu.	
Fuel Type is available with firmware version 4.5 or higher.	

Figure 5-20 Controller Settings

Overspeed Shutdown

Connect a digital voltmeter (DVM) to measure the output frequency. Start the generator set and manually adjust the engine speed by moving the throttle linkage.

Note: Be careful not to touch the hot silencer when reaching in to adjust the throttle linkage.

Increase the engine speed to at least 115% of the rated engine speed, 69 Hz on 60 Hz models. Verify that the generator set shuts down on an overspeed fault. If the overspeed shutdown does not operate, the generator set should shut down on an overfrequency fault after approximately 5 seconds.

Oil Pressure Low Shutdown

Connect a jumper wire from the LOP switch (lead 13) to the generator set ground. Start the generator set. Verify that the generator set shuts down after approximately 25–35 seconds of operation. Remove the jumper wire from the LOP switch and ground. Start the generator set and run it for at least 25–35 seconds to verify that the generator set does not shut down.

Overcrank Shutdown

Disconnect the fuel solenoid valve. Press the RUN button on the controller. Observe that the generator set cranks for 15 seconds and then rests for 15 seconds. Check that the generator set shuts down after the third crank/rest cycle.

Underspeed and Underfrequency Shutdowns

Close the throttle while the generator is running. The engine speed should decrease until the generator set shuts down and the controller indicates an Engine Speed Low Shutdown.

To check the underfrequency shutdown, use very small movements over a longer period of time to close the throttle. The genset may need to run at reduced frequency for about a minute before the Frequency Low Shutdown is triggered.

Locked Rotor Shutdown

Remove the connector from the starter relay (see Figure 5-34). Press RUN. Verify that the engine does not turn and the controller indicates a Locked Rotor fault.

Oil Temperature High Shutdown

Note: Testing the high engine temperature shutdown requires connecting a jumper wire across the temperature sensor connections. Because the temperature sensor can be difficult to reach, the jumper can be placed across pins 9 and 10 on connector P1 at the generator set controller, if desired.

Disconnect the harness (connector P7) at the oil temperature sensor (OTS). See Figure 5-22 for the temperature sensor location, or see the note above. Connect a jumper wire across the temperature sensor connections in connector P7 or connections P1-9 and P1-10 on the controller. See Figure 5-21. Press RUN to start the generator set. After 5 seconds, verify that the controller displays a high oil temperature fault. If the oil temperature remains high (jumper connected) without increasing, the generator set will run for 5 minutes in engine cooldown mode.

Press the OFF button on the controller and remove the jumper wire. Start the generator set and verify that the generator set does not enter the engine cooldown cycle or shut down on a high temperature fault. Reconnect P7 to the temperature sensor.

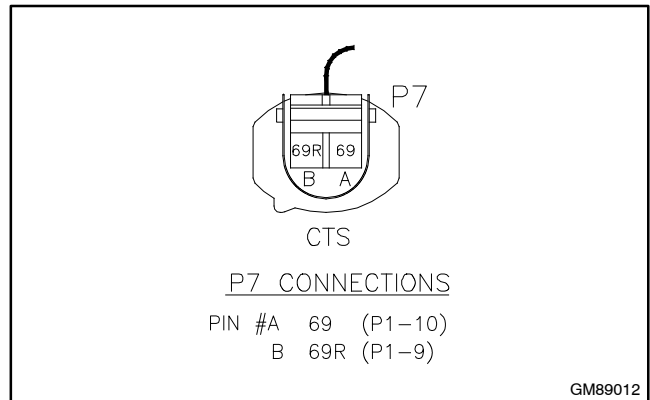

Figure 5-21 Temperature Sensor Connector P7

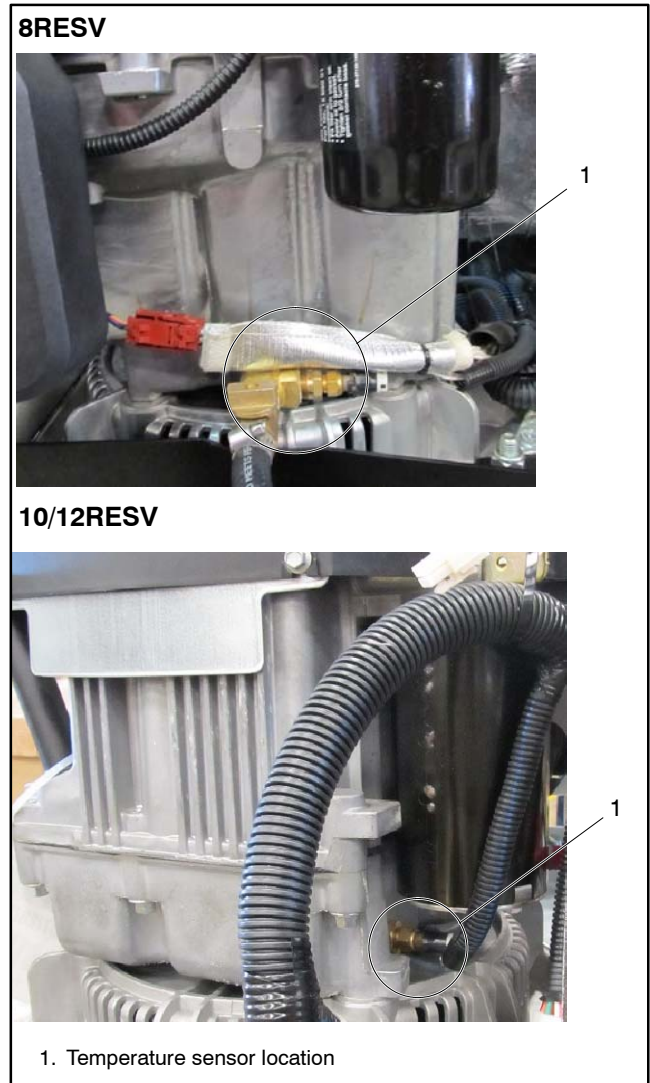
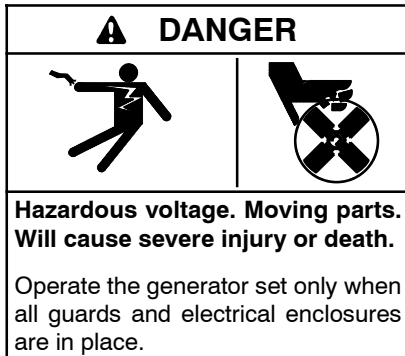

Figure 5-22 Temperature Sensor (OTS) Location

5.12.2 Fault Shutdown Switches

Check the low oil pressure and high engine temperature shutdown switches on the engine by performing the following tests. If the sensor does not function as described, replace it.



Servicing the generator set when it is operating. Exposed moving parts will cause severe injury or death. Keep hands, feet, hair, clothing, and test leads away from the belts and pulleys when the generator set is running. Replace guards, screens, and covers before operating the generator set.

Short circuits. Hazardous voltage/current will cause severe injury or death. Short circuits can cause bodily injury and/or equipment damage. Do not contact electrical connections with tools or jewelry while making adjustments or repairs. Remove all jewelry before servicing the equipment.

Temperature Sensor (OTS)

The temperature sensor (labelled OTS on the wiring diagram and schematic drawing) is used to monitor engine temperature for the high engine temperature fault shutdown. See Figure 5-22 for the temperature sensor location. Press the OFF button on the controller to stop the generator set and allow the generator set to cool. Disconnect the temperature sensor (or see the note, below) and use an ohmmeter to measure the resistance across the sensor. The sensor resistance varies with temperature and should be within the values shown in Figure 5-23. If the resistance is very low (indicating a short circuit) or very high (indicating an open circuit), replace the OTS.

Note: Because the temperature sensor can be difficult to reach, the resistance can be measured across pins 9 and 10 on connector P1 at the generator set controller, if desired. Disconnect P1 from the controller before checking the resistance across P1-9 and P1-10.

Note: The temperature sensor is located in the engine oil pan. Drain the engine oil before removing the switch.

Temperature, °C (°F)	Resistance, Ohms
30 (86)	2100-2400
100 (212)	180-200

Figure 5-23 Temperature Sensor OTS Resistance Readings

Low Oil Pressure (LOP) Switch

For the **8RESV(L)**, the low oil pressure (LOP) switch is located above the oil filter and underneath the black blower housing. For the **10/12RESV(L)**, the low oil pressure switch is located above the oil filter. See Figure 5-24. The oil pressure switch should be grounded when the engine is stopped (no oil pressure) and open when the engine is running.

Note: The low oil pressure switch is the same as the Oil Sentry™ switch in the engine service manual.

Before testing the LOP switch, check the oil level and add oil if necessary. Inspect the generator set engine for evidence of oil leaks.

To test the LOP switch:

1. Press the OFF button to stop the engine.
2. Disconnect lead 13 from the switch.
3. Use an ohmmeter or continuity tester to verify that the switch is closed (connected to the engine block).
4. Start the engine and verify that the switch opens after a few seconds.

If the LOP switch does not operate as described above, use a gauge to check the oil pressure:

1. Press the OFF button to stop the engine.
2. Remove the LOP switch and install an oil pressure gauge.
3. Start and run the generator set.
4. Verify that the engine oil pressure is within the range specified in Section 1, Specifications, before replacing the LOP switch.

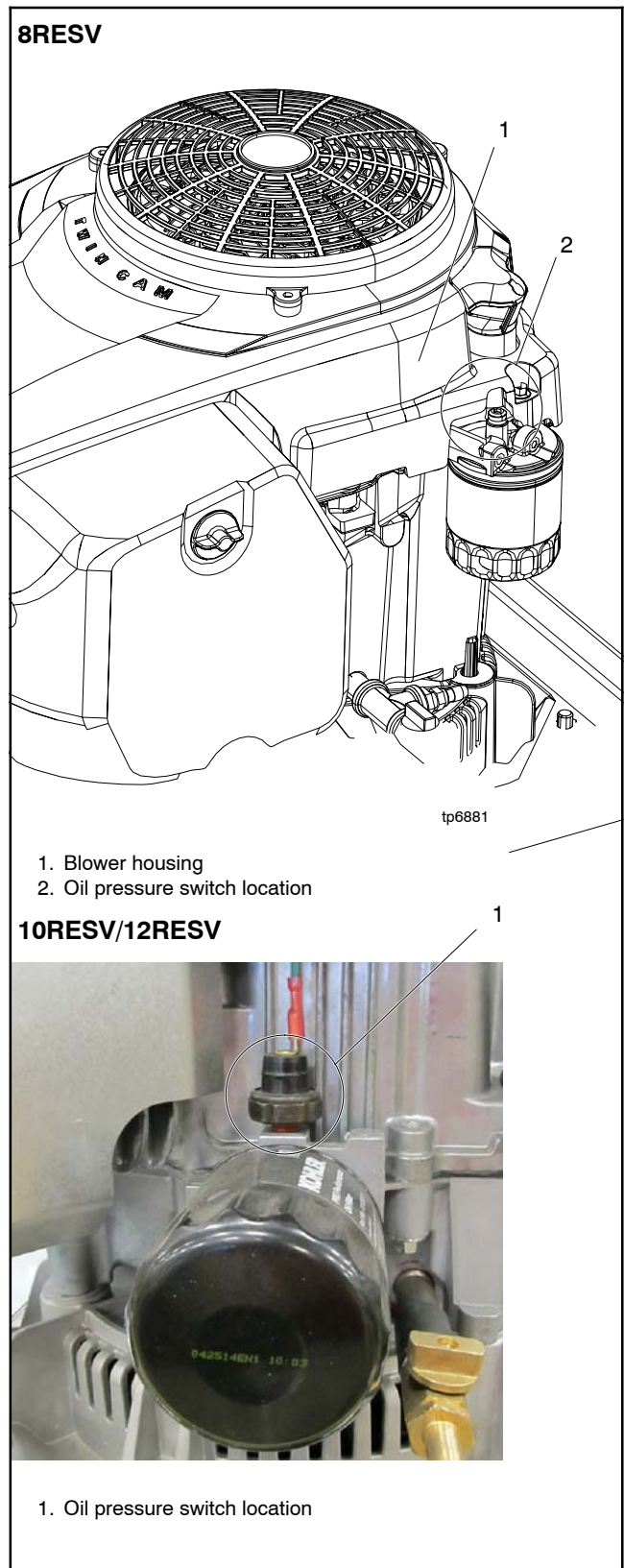
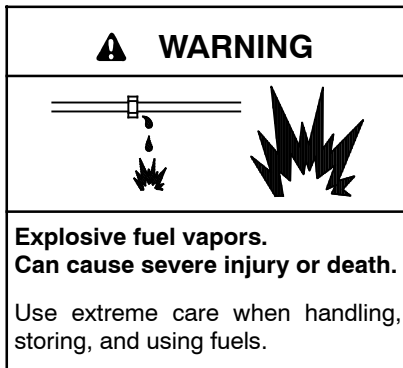

Figure 5-24 Oil Pressure Switch Location

5.13 Fuel Systems



The fuel system. Explosive fuel vapors can cause severe injury or death. Vaporized fuels are highly explosive. Use extreme care when handling and storing fuels. Store fuels in a well-ventilated area away from spark-producing equipment and out of the reach of children. Never add fuel to the tank while the engine is running because spilled fuel may ignite on contact with hot parts or from sparks. Do not smoke or permit flames or sparks to occur near sources of spilled fuel or fuel vapors. Keep the fuel lines and connections tight and in good condition. Do not replace flexible fuel lines with rigid lines. Use flexible sections to avoid fuel line breakage caused by vibration. Do not operate the generator set in the presence of fuel leaks, fuel accumulation, or sparks. Repair fuel systems before resuming generator set operation.

Gas fuel leaks. Explosive fuel vapors can cause severe injury or death. Fuel leakage can cause an explosion. Check the LPG vapor or natural gas fuel system for leakage by using a soap and water solution with the fuel system test pressurized to 6–8 ounces per square inch (10–14 inches water column). Do not use a soap solution containing either ammonia or chlorine because both prevent bubble formation. A successful test depends on the ability of the solution to bubble.

LPG liquid withdrawal fuel leaks. Explosive fuel vapors can cause severe injury or death. Fuel leakage can cause an explosion. Check the LPG liquid withdrawal fuel system for leakage by using a soap and water solution with the fuel system test pressurized to at least 90 psi (621 kPa). Do not use a soap solution containing either ammonia or chlorine because both prevent bubble formation. A successful test depends on the ability of the solution to bubble.

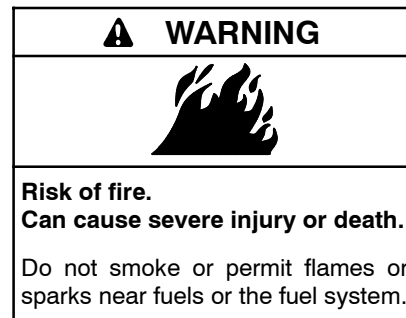

Servicing the fuel system. A flash fire can cause severe injury or death. Do not smoke or permit flames or sparks near the carburetor, fuel line, fuel filter, fuel pump, or other potential sources of spilled fuels or fuel vapors. Catch fuels in an approved container when removing the fuel line or carburetor.

The fuel supplier provides and maintains manual shut-off valves and the primary regulator. See the generator set installation manual for fuel pipe size recommendations. Verify that the fuel system capacity is adequate to supply the generator set plus all other gas appliances.

A factory-installed secondary regulator and 12 VDC solenoid valve are located in the front air intake compartment. The controller energizes the fuel solenoid valve to open at startup and deenergizes the valve to close at shutdown. The secondary fuel regulator reduces fuel pressure for delivery to the fuel block. The fuel flows from the fuel block to the carburetor in a gaseous state. The carburetor mixes the fuel with intake air for consumption by the engine.

Refer to the troubleshooting instructions in Section 4, Troubleshooting, to identify generator set operation problems that may be caused by an inadequate fuel supply, incorrect adjustments, or damaged fuel system components. Then use the instructions in this section to check fuel system components.

5.13.1 Fuel Solenoid Valve

A solenoid valve upstream of the regulator and the flexible fuel connector provides automatic fuel on/off control. See Figure 5-25. The engine starting battery powers the solenoid valve and the engine starting controls open the valve when the engine cranks or runs.

Fuel Valve Operation Test Procedure

1. Disconnect the positive (+) battery lead from the gas valve terminal.
2. Apply 12 VDC to the gas valve terminal and listen for an audible click, indicating that the valve actuates.
3. Replace the gas valve if it does not actuate in step 2.

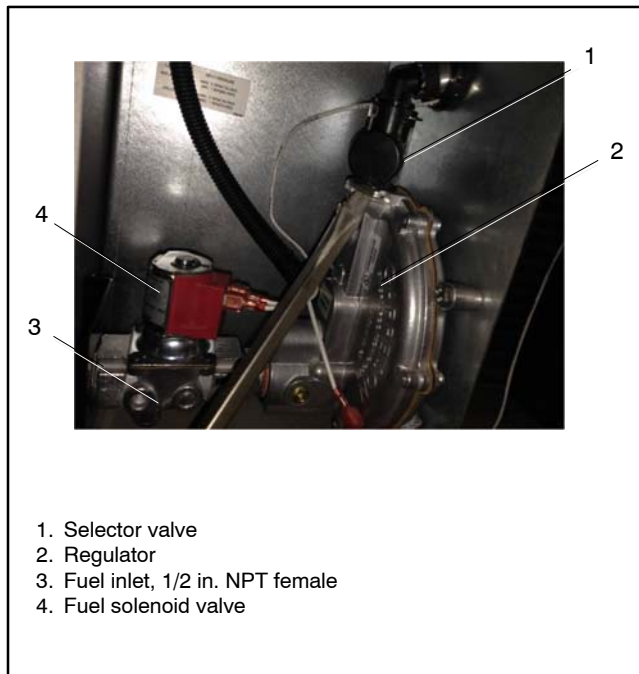

Figure 5-25 Fuel System

5.13.2 Capacitive Discharge Ignition (CDI) Timing

These systems use a capacitive discharge (CD) coil. With CDI fixed timing, ignition timing and spark remains constant regardless of engine speed. Timing of spark is controlled by location of the flywheel magnet group.

For the 8RESV, a typical fixed ignition system consists of:

- 1 magnet assembly that is permanently affixed to the flywheel
- 1 electronic capacitive-discharge or magnetic discharge ignition module that mounts on engine crankcase
- 1 stop switch (or key switch) that grounds modules to stop engine
- 1 spark plugs

For the 10RESV and 12RESV, a typical fixed ignition system consists of:

- 1 magnet assembly that is permanently affixed to the flywheel
- 2 electronic capacitive-discharge or magnetic discharge ignition modules that mount on the engine crankcase
- 1 stop switch (or key switch) that grounds modules to stop the engine
- 2 spark plugs

See the engine service manual for ignition system service information.

5.13.3 Fuel Regulators

The typical gaseous fuel system uses two regulators. The primary regulator reduces the line pressure to an allowable inlet pressure for the secondary regulator. The fuel supplier provides and maintains the primary regulator. The secondary regulator is factory-installed on the generator set and is designed for a maximum inlet pressure of 2.7 kPa (6 oz./in.²) or 280 mm (11 in.) water column.

Note: Do not attempt to adjust the fuel mixture or engine speed by adjusting the regulators.

The fuel lockoff prevents fuel flow when the engine is not operating. See Figure 5-27. Do not try to adjust the fuel pressure, fuel mixture, or engine speed using the fuel lockoff.

Checking the Fuel Pressure

Use a gauge or manometer to check the fuel pressure at the secondary regulator inlet. See Figure 5-27. Measure the fuel pressure with the generator set running at rated load. Contact the fuel supplier if the inlet pressure is not within the range shown in Figure 5-26.

Fuel	Fuel Pressure Required
Natural Gas	0.87–2.7 kPa (3.5–11 inches H ₂ O)
LPG	1.7–2.7 kPa (7–11 inches H ₂ O)

Figure 5-26 Fuel Pressure Requirements

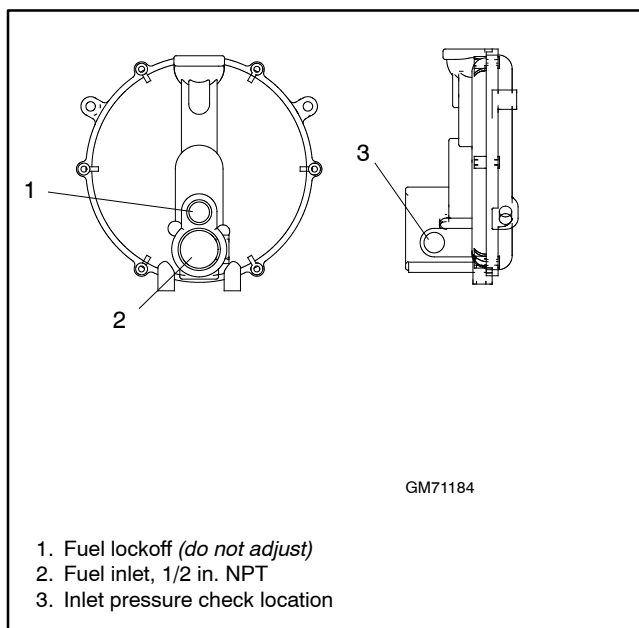

Figure 5-27 Fuel Regulator

5.14 Fuel Conversion

The multi-fuel system allows conversion from natural gas (NG) to LPG (or vice-versa) in the field while maintaining emissions-standard compliance. A trained technician or an authorized distributor/dealer can convert the fuel system.

⚠ WARNING

Accidental starting.
Can cause severe injury or death.

Disconnect the battery cables before working on the generator set. Remove the negative (-) lead first when disconnecting the battery. Reconnect the negative (-) lead last when reconnecting the battery.

Disabling the generator set. Accidental starting can cause severe injury or death. Before working on the generator set or equipment connected to the set, disable the generator set as follows: (1) Press the generator set off/reset button to shut down the generator set. (2) Disconnect the power to the battery charger, if equipped. (3) Remove the battery cables, negative (-) lead first. Reconnect the negative (-) lead last when reconnecting the battery. Follow these precautions to prevent the starting of the generator set by the remote start/stop switch.

⚠ WARNING

Risk of fire.
Can cause severe injury or death.

Do not smoke or permit flames or sparks near fuels or the fuel system.

Servicing the fuel system. A flash fire can cause severe injury or death. Do not smoke or permit flames or sparks near the carburetor, fuel line, fuel filter, fuel pump, or other potential sources of spilled fuels or fuel vapors. Catch fuels in an approved container when removing the fuel line or carburetor.

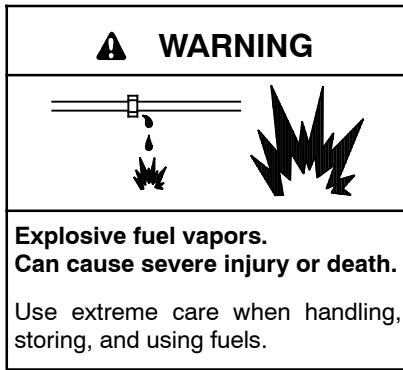

The fuel system. Explosive fuel vapors can cause severe injury or death. Vaporized fuels are highly explosive. Use extreme care when handling and storing fuels. Store fuels in a well-ventilated area away from spark-producing equipment and out of the reach of children. Never add fuel to the tank while the engine is running because spilled fuel may ignite on contact with hot parts or from sparks. Do not smoke or permit flames or sparks to occur near sources of spilled fuel or fuel vapors. Keep the fuel lines and connections tight and in good condition. Do not replace flexible fuel lines with rigid lines. Use flexible sections to avoid fuel line breakage caused by vibration. Do not operate the generator set in the presence of fuel leaks, fuel accumulation, or sparks. Repair fuel systems before resuming generator set operation.

Gas fuel leaks. Explosive fuel vapors can cause severe injury or death. Fuel leakage can cause an explosion. Check the LPG vapor or natural gas fuel system for leakage by using a soap and water solution with the fuel system test pressurized to 6–8 ounces per square inch (10–14 inches water column). Do not use a soap solution containing either ammonia or chlorine because both prevent bubble formation. A successful test depends on the ability of the solution to bubble.

LPG liquid withdrawal fuel leaks. Explosive fuel vapors can cause severe injury or death. Fuel leakage can cause an explosion. Check the LPG liquid withdrawal fuel system for leakage by using a soap and water solution with the fuel system test pressurized to at least 90 psi (621 kPa). Do not use a soap solution containing either ammonia or chlorine because both prevent bubble formation. A successful test depends on the ability of the solution to bubble.

Fuel Conversion Procedure

The fuel selector valve allows field-conversion between natural gas (NG) and LPG. The valve is factory-set to comply with applicable emission standards and to provide the best possible hot and cold starting.

Note: Do not adjust the factory-set adjustment screw on the selector valve. Adjusting the screw may violate federal and state laws. See Figure 5-32.

Use the following procedure to convert the fuel system. The procedure includes removing the side panel, removing the cap from the fuel selector valve, and making the fuel selection.

See Figure 5-28 for fuel system components.

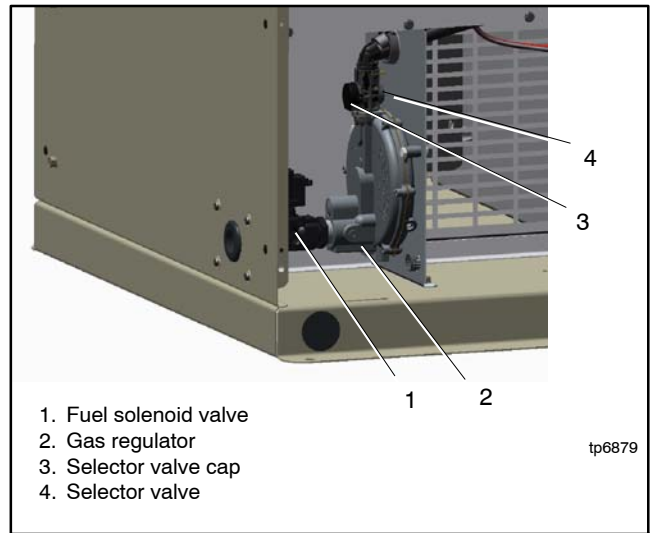

Figure 5-28 Fuel System

1. Press the OFF button on the generator set controller.
2. Disconnect the power to the battery charger.
3. Disconnect the generator set engine starting battery, negative (-) lead first.
4. Turn off the fuel supply.
5. Remove panel screws and remove left side louvered panel. Figure 5-29.

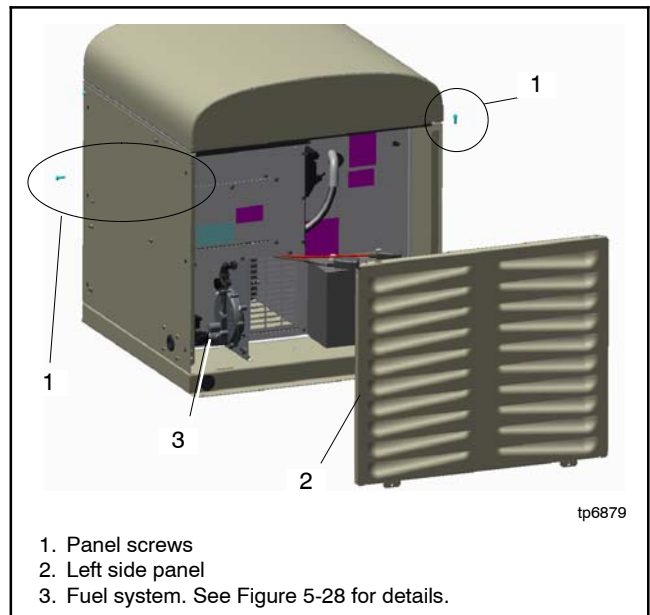

Figure 5-29 Remove Left Panel

- Remove the cap from the fuel selector valve. See Figure 5-30. Insert a flat head screwdriver under the lip of the cap and push it upwards. Keep the cap close by as it is needed to switch fuels in the next step.

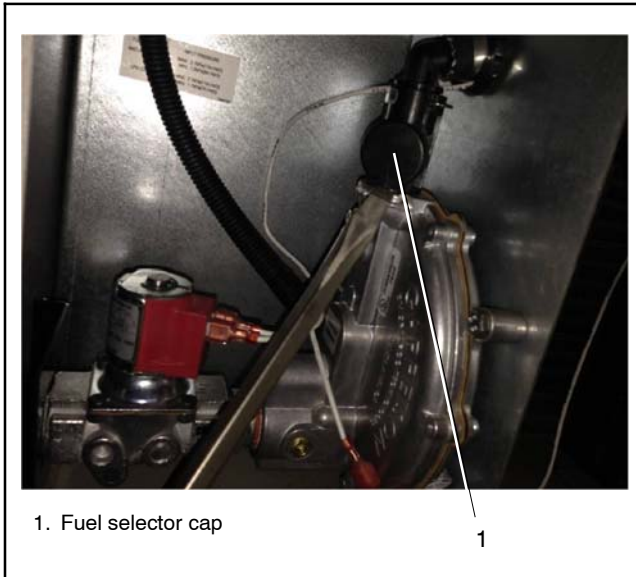

Figure 5-30 Cap Removal

- See Figure 5-31. Use the cap in the orientation shown to turn the selector valve to NG or LPG. See Figure 5-32 for valve positions.

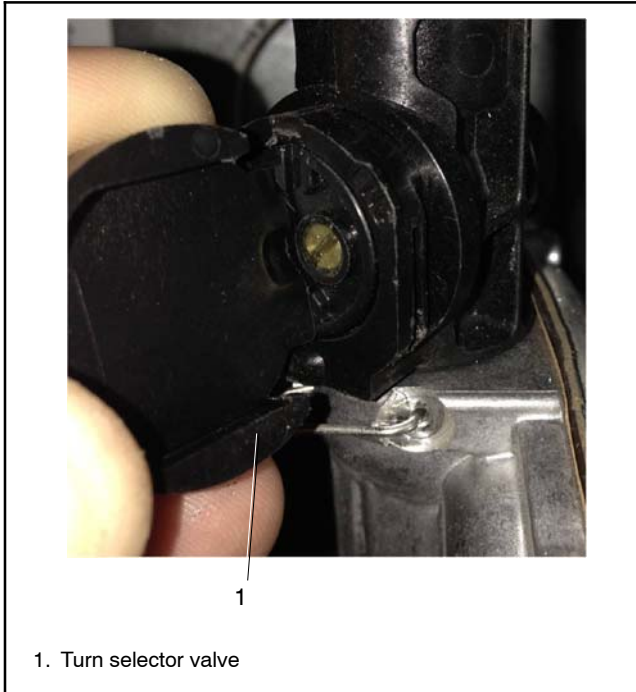

Figure 5-31 Fuel Selection

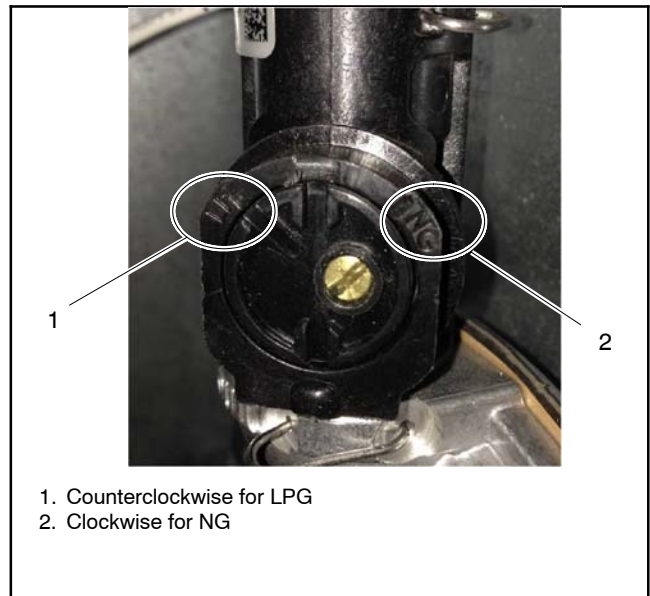

Figure 5-32 Valve Positions

- Replace the cap.
- Connect and turn on the fuel supply (ensure that the fuel supply matches the fuel setting).
- Reconnect the generator set engine starting battery leads, negative (-) lead last.
- Reconnect power to the battery charger.
- Reassemble the left side panel.
- Start the generator set by pressing the RUN button on the generator set controller.
- Check for leaks using a gas leak detector.
- Run the generator set and check the operation.
- Press the OFF button to shut down the generator set.

Rating

Converting the fuel will change the generator set rating. See the generator set specification sheet for ratings with natural gas and LPG. When converting to LPG from factory settings, order a new nameplate with the updated rating and fuel information from an authorized distributor/dealer, if necessary. Provide the following information from the original nameplate:

- Model Number
- Spec Number
- Serial Number
- Fuel (original and new)
- kW
- kVA
- Amps
- Volts
- Hz

5.14.1 Fuel Selector Valve Adjustment Screw

The fuel system is factory-adjusted to comply with applicable emission standards and to provide the best possible hot and cold starting. If the fuel selector valve requires adjustment, obtain a new fuel selector valve to replace the factory-installed valve. See Figure 5-28 for the fuel selector valve location. Refer to the generator set Parts Catalog for the fuel selector valve part number.

Note: Adjusting the factory-installed fuel selector valves on emissions-certified generator sets will void the emission certification. Do not change the adjustment screw setting.

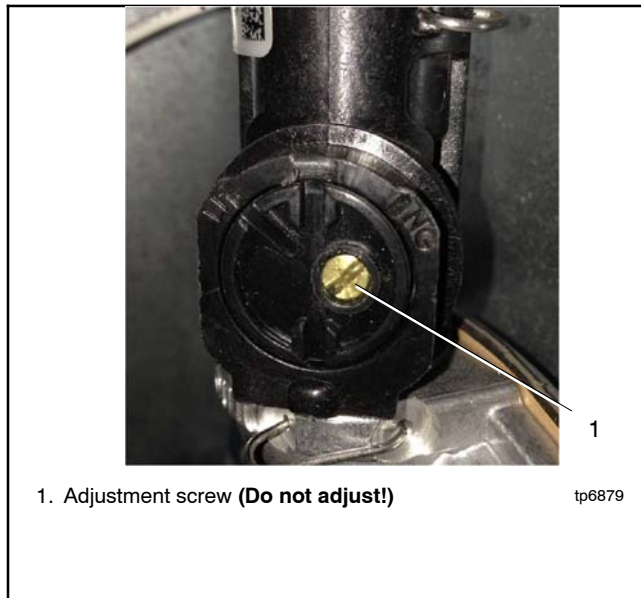

Figure 5-33 Valve Positions

5.15 Starter and Run Relay

The starter relay (P10) and the run relay (P11) are located underneath the controller inside the junction box. To access the relays, remove the two controller screws and lift the controller out of the junction box. Check for lead 71 to determine which relay is the starter relay. See Figure 5-34.

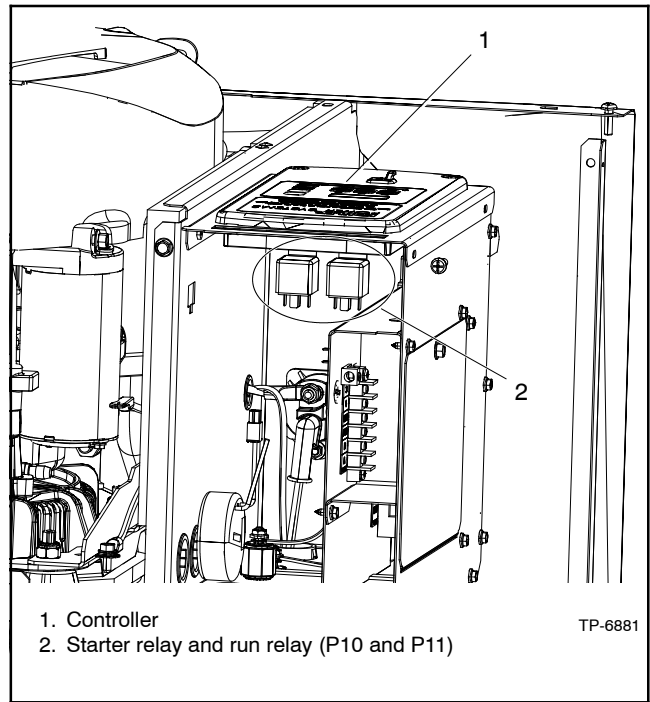

Figure 5-34 Starter Relay Location

The starter and run relays contains an internal diode across the relay coil. See Figure 5-35. Continuity checks across the coil terminals will show continuity (low resistance) in one direction and an open circuit in the other.

Figure 5-36 shows the relay connections.

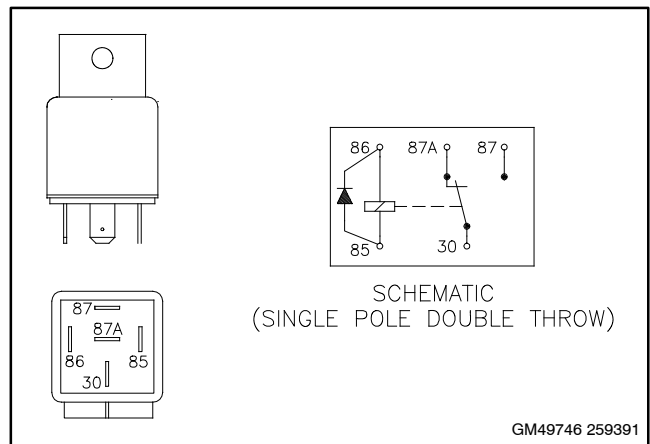
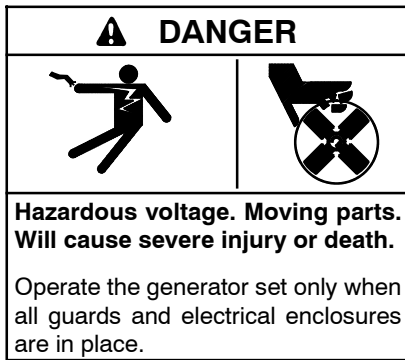

Figure 5-35 Starter Relay

Relay Terminal	Starter Relay Lead	Run Relay Lead
30	P1	P2
85	N3	N4
86	71	70
87	N/C	N/C
87A	71A	70A

Figure 5-36 Starter Relay Connections

5.16 Continuity Checks



Short circuits. Hazardous voltage/current will cause severe injury or death. Short circuits can cause bodily injury and/or equipment damage. Do not contact electrical connections with tools or jewelry while making adjustments or repairs. Remove all jewelry before servicing the equipment.

Testing live electrical circuits. Hazardous voltage or current will cause severe injury or death. Have trained and qualified personnel take diagnostic measurements of live circuits. Use adequately rated test equipment with electrically insulated probes and follow the instructions of the test equipment manufacturer when performing voltage tests. Observe the following precautions when performing voltage tests: (1) Remove all jewelry. (2) Stand on a dry, approved electrically insulated mat. (3) Do not touch the enclosure or components inside the enclosure. (4) Be prepared for the system to operate automatically.
(600 volts and under)

To further check generator set components, disconnect the battery and remove wiring harness plugs from the controller circuit board. Use an ohmmeter to check the continuity of the components listed in Figure 5-37. Also see Section 7, Wiring Diagrams.

Figure 5-37 gives resistance readings for functional components. A zero reading on the ohmmeter indicates continuity. No ohmmeter reading indicates very high resistance or an open circuit. A measurement that varies significantly from the value shown in the table indicates a faulty component; replace faulty components.

Note: Disconnect the generator set battery before performing continuity checks to prevent damage to the ohmmeter.

For rotor and stator resistance and continuity checks, see Section 5.4, Stator, and Section 5.5, Main Field (Rotor).

Component	Ohmmeter Connections	Ohmmeter Scale	Generator Set State	Ohmmeter Readings for Operative Components
P1 wiring harness	P1-2 and ground	R x 1	OFF	Less than 1 ohm (continuity) Any other reading indicates a poor ground connection.
	P2-6 and P2-7 (stator leads 11 and 44)	R x 1	OFF	Less than 1 ohm (continuity). If no continuity, check wiring.
	P2-3 and P2-4 (stator leads 55 and 66)	R x 1	OFF	Less than 1 ohm (continuity). If no continuity, check wiring.
Controller wiring	P1-1 and battery positive (+)	R x 100	OFF	Less than 1 ohm (continuity). If no continuity is found, check wiring.
Auxiliary winding breaker (20-amps)	P2-3 and stator lead 55	R x 100	OFF	Less than 1 ohm (continuity). If no continuity is found, check for an open circuit.
Low oil pressure (LOP) switch *	Lead 13 and ground (engine block)	R x 100	OFF	Less than 1 ohm (continuity). No continuity indicates a faulty switch and/or wiring.
Temperature sensor (OTS) *	P1-9 and P1-10	R x 1000	OFF	180-2500 ohms, depending on engine temperature. See Section 5.12.2. Less than 1 ohm or an open circuit indicates faulty wiring or a faulty sensor.

* See Section 5.12.2, Fault Shutdown Switches

Figure 5-37 Continuity Checks

Notes

Section 6 Disassembly/Reassembly

This section provides instructions for the disassembly and reassembly of the generator set alternator. Before beginning the generator disassembly or reassembly procedure, carefully read all safety precautions at the beginning of this manual.

The engine and generator set may use both American Standard and metric hardware. Use the correct size tools to prevent rounding of the bolt heads and nuts.

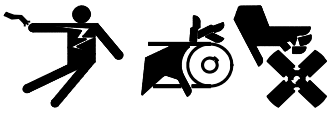
⚠ WARNING

Accidental starting. Can cause severe injury or death.
Disconnect the battery cables before working on the generator set. Remove the negative (-) lead first when disconnecting the battery. Reconnect the negative (-) lead last when reconnecting the battery.

Disabling the generator set. Accidental starting can cause severe injury or death. Before working on the generator set or equipment connected to the set, disable the generator set as follows: (1) Move the generator set master switch to the OFF position. (2) Disconnect the power to the battery charger. (3) Remove the battery cables, negative (-) lead first. Reconnect the negative (-) lead last when reconnecting the battery. Follow these precautions to prevent starting of the generator set by an automatic transfer switch, remote start/stop switch, or engine start command from a remote computer.

⚠ DANGER

Hazardous voltage. Will cause severe injury or death.
Disconnect all power sources before opening the enclosure.

⚠ WARNING

Hot engine and exhaust system. Can cause severe injury or death.
Do not work on the generator set until it cools.

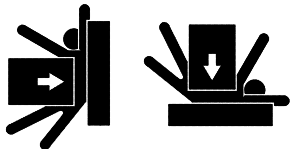
Servicing the alternator. Hot parts can cause severe injury or death. Avoid touching the alternator field or exciter armature. When shorted, the alternator field and exciter armature become hot enough to cause severe burns.

Servicing the exhaust system. Hot parts can cause severe injury or death. Do not touch hot engine parts. The engine and exhaust system components become extremely hot during operation.

⚠ WARNING

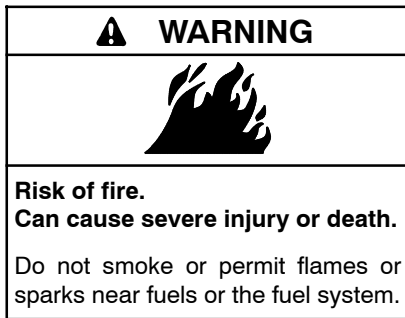
Unbalanced and elevated weight. Improper lifting can cause severe injury or death and equipment damage.
Do not lift the generator set from the engine or alternator eyes. Never stand under a unit being lifted. Always maintain a safe distance from the unit being lifted. See the lifting instructions in the installation manual that was provided with the unit.

6.1 Initial Steps

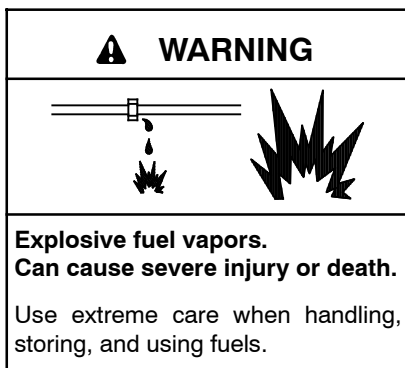

Servicing the fuel system. A flash fire can cause severe injury or death. Do not smoke or permit flames or sparks near the carburetor, fuel line, fuel filter, fuel pump, or other potential sources of spilled fuels or fuel vapors. Catch fuels in an approved container when removing the fuel line or carburetor.



The fuel system. Explosive fuel vapors can cause severe injury or death. Vaporized fuels are highly explosive. Use extreme care when handling and storing fuels. Store fuels in a well-ventilated area away from spark-producing equipment and out of the reach of children. Never add fuel to the tank while the engine is running because spilled fuel may ignite on contact with hot parts or from sparks. Do not smoke or permit flames or sparks to occur near sources of spilled fuel or fuel vapors. Keep the fuel lines and connections tight and in good condition. Do not replace flexible fuel lines with rigid lines. Use flexible sections to avoid fuel line breakage caused by vibration. Do not operate the generator set in the presence of fuel leaks, fuel accumulation, or sparks. Repair fuel systems before resuming generator set operation.

Gas fuel leaks. Explosive fuel vapors can cause severe injury or death. Fuel leakage can cause an explosion. Check the LPG vapor or natural gas fuel system for leakage by using a soap and water solution with the fuel system test pressurized to 6–8 ounces per square inch (10–14 inches water column). Do not use a soap solution containing either ammonia or chlorine because both prevent bubble formation. A successful test depends on the ability of the solution to bubble.

LPG liquid withdrawal fuel leaks. Explosive fuel vapors can cause severe injury or death. Fuel leakage can cause an explosion. Check the LPG liquid withdrawal fuel system for leakage by using a soap and water solution with the fuel system test pressurized to at least 90 psi (621 kPa). Do not use a soap solution containing either ammonia or chlorine because both prevent bubble formation. A successful test depends on the ability of the solution to bubble.

Perform the following steps before disassembling the generator set.

1. Press the OFF button on the controller.
2. Disconnect AC power to the generator set by opening the upstream circuit breaker. (AC power is connected to the generator set for battery charging and AC-powered accessories.)
3. Disconnect the generator set engine starting battery, negative (-) lead first.
4. Shut off the fuel supply. Disconnect the fuel supply line. Ventilate the area to clear fumes.
5. Allow the generator set and engine to cool.
6. Drain the oil.
7. Verify that any hoists or lifting devices used in the disassembly or reassembly procedure are rated for the weight of the generator set.

Model	Weight
8RESV(L)	170 kg (375 lb.)
10/12REV(L)_	196 kg (433 lb.)

6.2 Disassembly

The disassembly procedure explains how to disassemble the generator set enclosure and other parts in order to access the alternator and engine for service. The procedure provides important information to minimize disassembly time and indicates where special configurations exist which may require taking notes.

Removing the enclosure

Remove the generator set enclosure as described in the following steps. See Figure 6-1.

1. Open the enclosure roof.
2. Press the OFF button on the controller.

Important: Do not allow the roof to hang from the hinge in an overextended or unsupported position. Without support from the piston, the weight of the roof will damage the sheet metal. Get assistance to hold the roof while removing the hinge bolts.

3. To remove the roof:
 - a. Raise the enclosure roof and use a screwdriver to slide the retaining ring off the support piston.
 - b. Disconnect the roof support piston.
 - c. With assistance to support the roof, remove the hinge bolts and then remove the roof.
4. Remove the two left-side or air-intake-panel screws and pull the left side panel up and off.
5. Remove the two right-side or exhaust-panel screws and pull the right side panel up and off.
6. Remove the wing nut and bolt holding the front panel to the bulkhead and pull the front panel up and off.
7. To remove the rear panel:
 - a. Open the junction box access panel. Disconnect any external leads that enter the junction box through the hole in the rear panel. Pull the leads and conduit through the rear panel.
 - b. Remove the five hexhead screws on the rear panel and then lift and remove the rear panel.

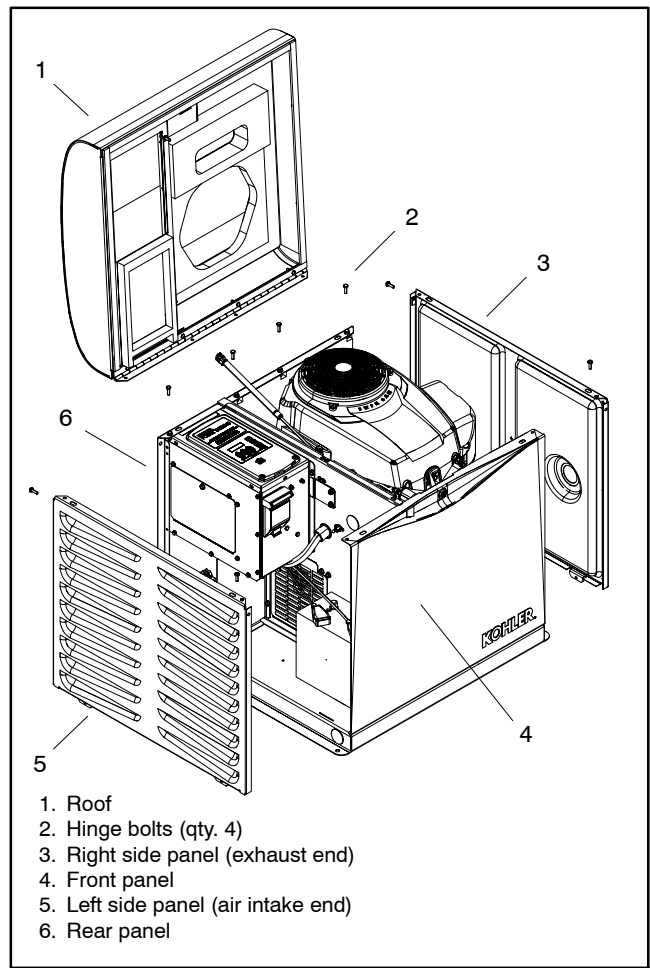

Figure 6-1 Enclosure

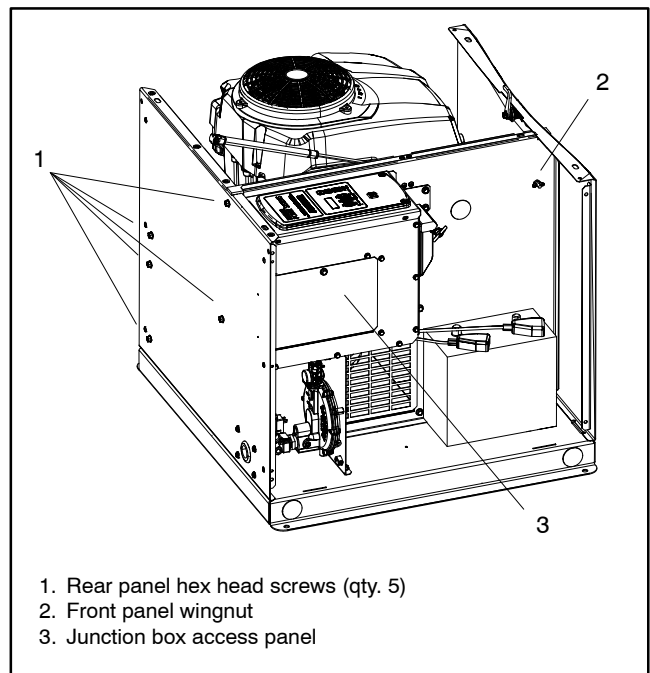

Figure 6-2 Front and Rear Panels

Disconnecting the electrical leads and harnesses

8. Remove the two controller screws to raise the controller and then disconnect the P2 controller plug.
9. Disconnect the following alternator harness leads in the junction box. Pull the leads and conduit through the bulkhead. See the wiring diagrams in Section 7.
 - a. Leads 1 and 4 from the circuit breaker

Note: For **10RESV** and **12RESV** models, leads 1 and 4 must thread through the current transformer (CT) from opposing directions. Before disconnecting the leads, take note of how the wires cross through the current transformer for reference when reconnecting the leads. See Figure 6-3.

- b. Quick connection leads 55 and 55F on the 20 Amp auxiliary winding circuit breaker
 - c. LO and neutral Leads connected to the red insulator on the bottom of the junction box.
10. Disconnect the positive lead that connects the starter motor to the starter solenoid.
11. Disconnect P6 plug to the stepper motor, leads 1A, 1B, 2A, and 2B.
12. Disconnect P7 plug to the oil temperature sensor, leads 69 and 69R.
13. Disconnect P8 plug to the ignition coil and the low oil pressure switch, leads IGN and 13.
14. Unplug the carburetor heater (if equipped) from the 120 VAC receptacle.
15. Disconnect the engine grounding strap.
16. Disconnect the wires and cables on the engine block ground.

Note: Verify that the fuel has been turned off as instructed in Section 6.1.

17. Remove the fuel line pin and disconnect the fuel line at the carburetor.

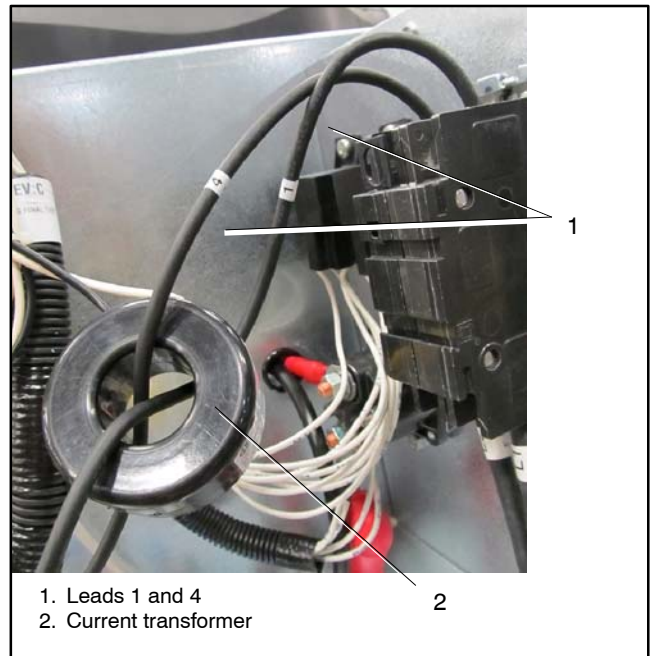

Figure 6-3 Current Transformer

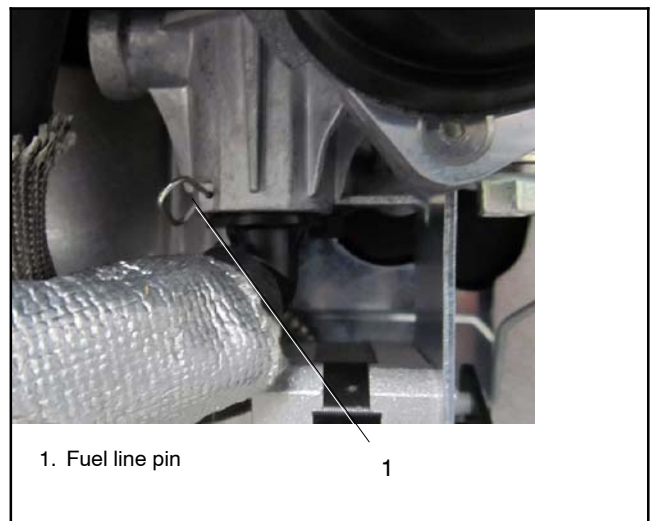
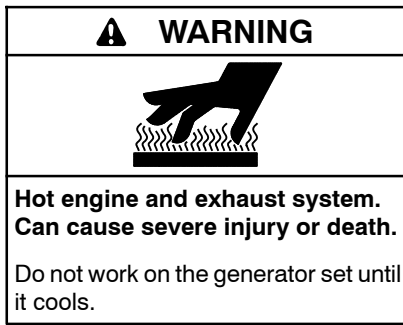

Figure 6-4 Fuel Line

Hoisting the engine and alternator



Servicing the exhaust system. Hot parts can cause severe injury or death. Do not touch hot engine parts. The engine and exhaust system components become extremely hot during operation.

18. Place a 273 mm (10-3/4 in.) block of wood to support the back corner of the mounting plate before removing the bulkhead.

Note: If the corner of the mounting plate is not supported, the weight of the engine and alternator assembly can bend the sheet metal.

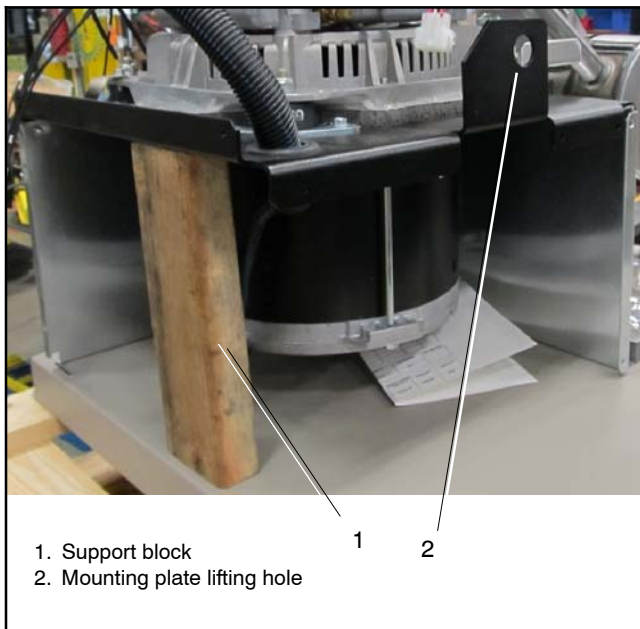

Figure 6-5 Support Block

19. Remove the five hex head screws on the bulkhead and then lift and remove the bulkhead.

Note: Removing the screws on the bulkhead will detach the alternator vent.

20. Remove the six screws connecting the mounting plate to the alternator box.

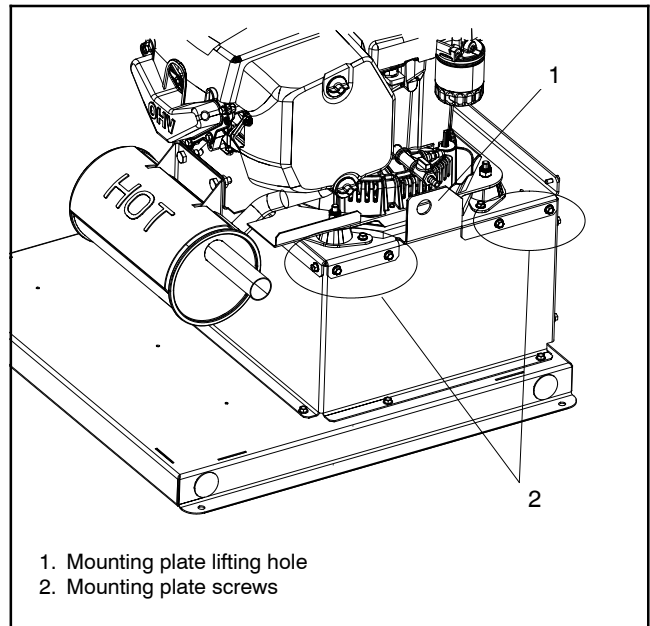

Figure 6-6 Mounting Plate Connections

21. Connect a hoist to the lifting holes in the mounting plate. Lift and remove the alternator and engine assembly.

Note: Use a hoist or lifting device that is rated for the weight of the generator set. See Section 6.1.

22. Either lay the assembly on its side and add a block under the engine for support, or remove the screen from the top of the engine blower housing and turn the assembly over to rest on the blower housing. See Figure 6-7.

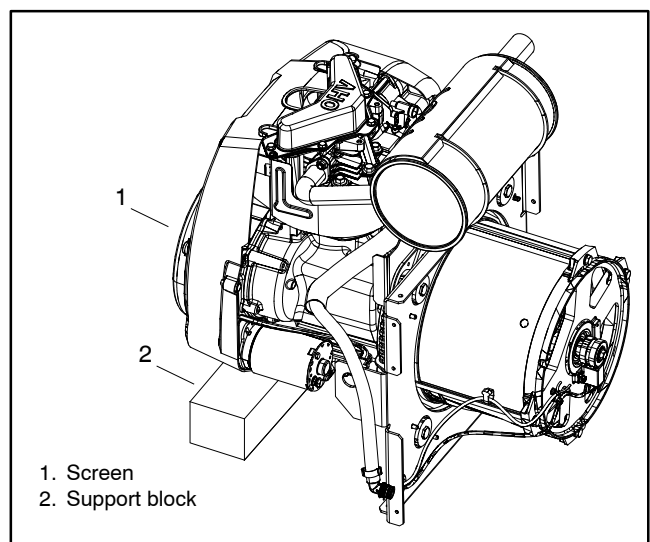



Figure 6-7 Engine and Alternator Assembly

Disassembling the alternator

⚠ WARNING

Hot engine and exhaust system. Can cause severe injury or death.
Do not work on the generator set until it cools.

Servicing the alternator. Hot parts can cause severe injury or death. Avoid touching the alternator field or exciter armature. When shorted, the alternator field and exciter armature become hot enough to cause severe burns.

23. Remove and check the brushes. See Figure 6-8.

Note: The brushes are spring-loaded and captured in the brush holder.

- a. Remove two screws.
- b. Remove the brush holder from the end bracket.
- c. Inspect the brushes. Replace brushes if they show uneven wear or when they are worn to half of their original size. See Section 5.7, Brushes.

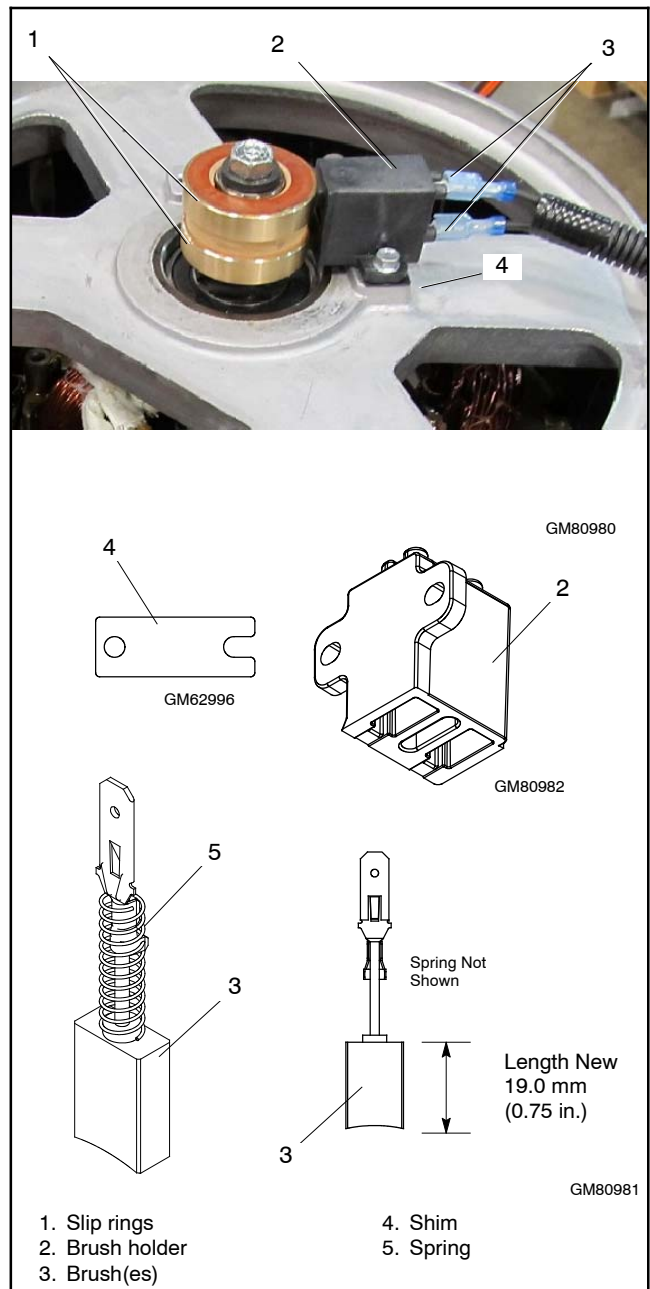

Figure 6-8 Brush Assembly

24. Remove the alternator overbolts and centering washers. See Figure 6-9.

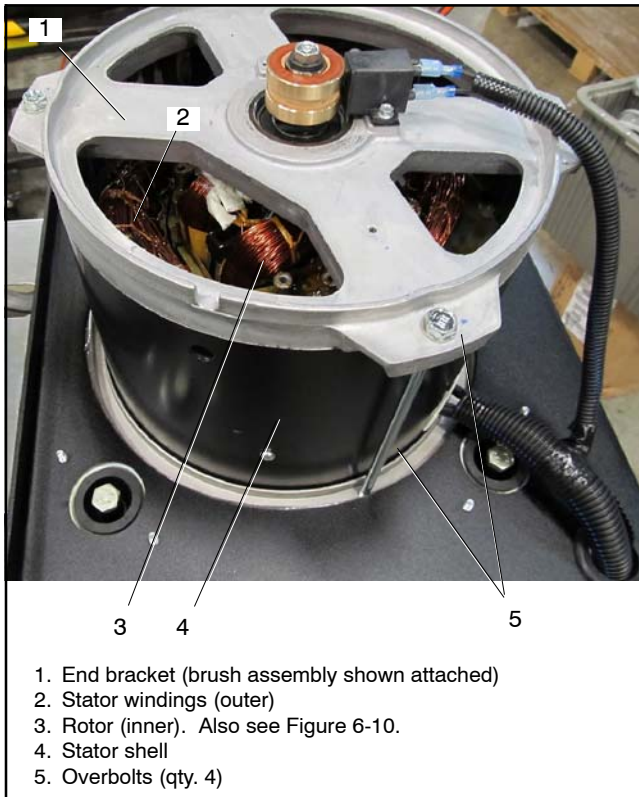

Figure 6-9 Alternator Assembly

25. Using a soft-faced hammer, strike the sides of the end bracket with medium-force blows to remove the end bracket from the stator or remove the end bracket from the stator using a puller. Set the end bracket assembly aside.

26. The stator leads are routed through the bulkhead and into the controller junction box. Carefully pull the leads out of the junction box. Pull the leads and conduit out through the bulkhead to free the alternator for removal.

27. Carefully pull the stator from the rotor. See Figure 6-9.

28. Remove the rotor as follows:

a. Loosen but do not remove the rotor thru-bolt. Use a strap wrench on the rotor to keep the rotor from turning during loosening, if necessary. See Figure 6-10.

b. Loosen the rotor assembly by striking the side of the rotor with a soft-faced hammer to loosen it from the tapered crankshaft fitting. See Figure 6-10. Rotate the rotor and strike it on alternate sides until it can be rocked slightly back and forth.

Note: Do not strike the slip rings.

c. Remove the thru-bolt and the rotor. Set the rotor assembly aside.

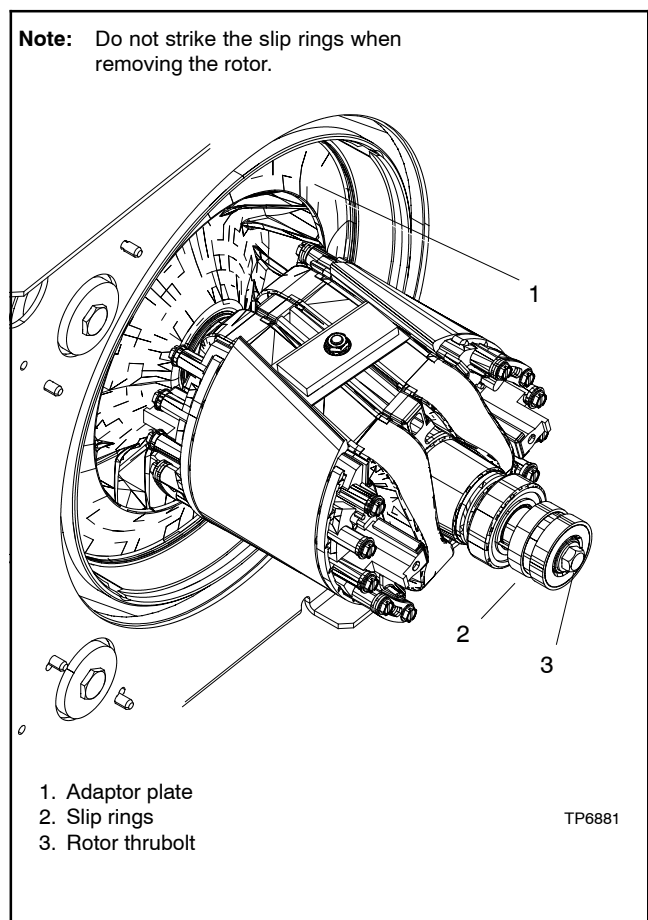

Figure 6-10 Rotor Assembly with Thru-bolt

Removing the Mounting Plate and Silencer

29. Remove vibromount bolts to disconnect the mounting plate from the engine.

Note: Do not remove the vibromounts unless the vibromounts require servicing.

Note: Correctly orienting the adapter plate to the engine is critical when remounting the engine. If the adapter plate must be removed, mark the adapter plate and the engine with a pen for orientation when remounting.

30. If needed, remove the four adapter plate bolts and then remove the adapter plate. In most instances when servicing the engine, removing the adapter plate is not necessary.

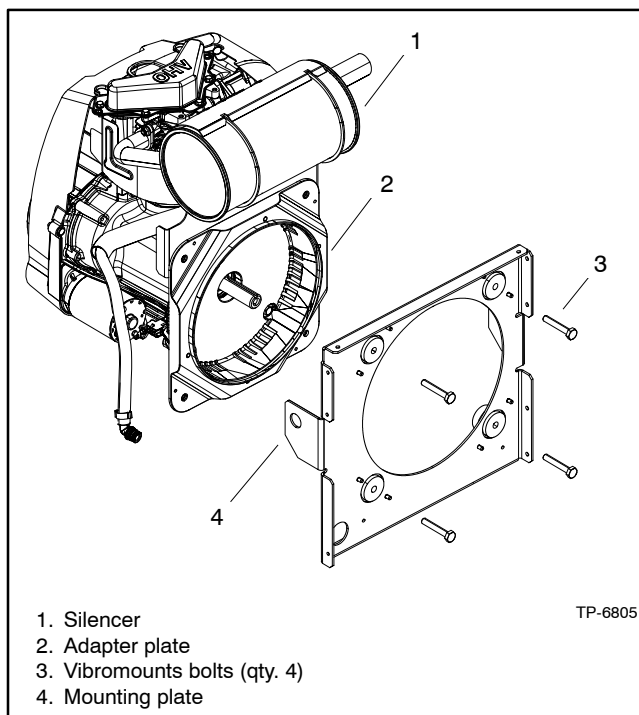

Figure 6-11 Engine and Mounting Plate

Note: Obtain a new exhaust gasket before removing the silencer.

31. Remove the two bolts on the silencer brackets.

32. Disconnect the silencer from the engine at the two flange connections and remove the silencer. See Figure 6-12.

Note: Use new exhaust gaskets when re-installing the silencer.

Note: Do not remove the exhaust flange bolt studs unless necessary for servicing.

33. Refer to the engine service manual to disassemble the engine components.

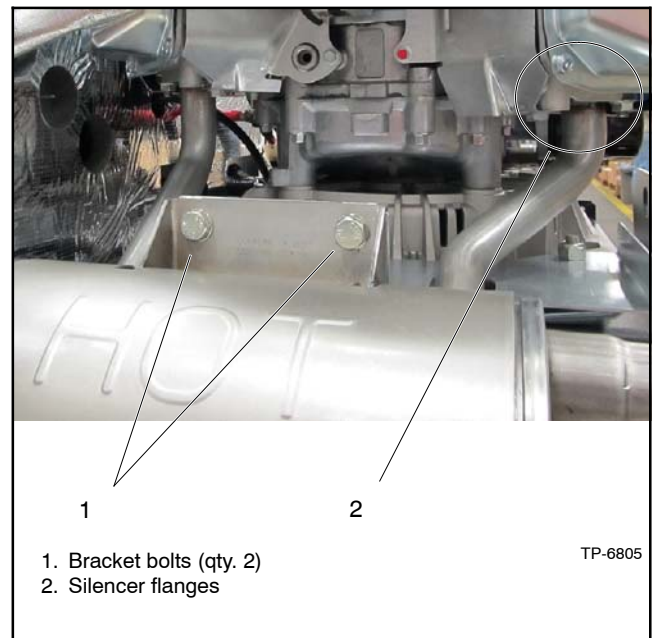

Figure 6-12 Silencer Connections

6.3 Reassembly

Attaching the Mounting Plate and Silencer

1. Install the exhaust system. See Figure 6-12.

Note: Use new exhaust gaskets when re-installing the silencer.

- a. Using new gaskets, connect the engine exhaust silencer to the engine at the flanges. Do not completely tighten the mounting hardware at this time.
 - b. Secure the silencer bracket to the adapter plate.
 - c. Torque the nuts securing the engine silencer flange to the engine to 24.4 Nm (18 ft. lb.).
2. Reinstall the adapter plate onto the engine, if necessary, using four 3/8-16 x 1-1/4 in. hex cap bolts and washers.

Note: Correctly aligning the adapter plate to engine is critical when remounting the engine. Realign the engine and adapter plate using the pen marks made when removing the adapter.

- a. Torque the bolts to 53 Nm (39 ft. lb.).
3. Attach the mounting plate using four hex cap bolts and nuts.
 - a. Torque the bolts to 45 Nm (34 ft. lb.).

Assembling the alternator

4. Install the rotor. See Figure 6-13.
 - a. Drain oil from the engine and remove the guard. See Figure 6-14.
 - b. Invert the engine, supporting it with a block under flywheel.
 - c. Clean the crankshaft stub and mating surface on the fan hub. Do not use antiseize compound when reassembling the rotor.
 - d. Install the rotor onto the engine crankshaft.
 - e. Thread the thrubolt with hardened washer through the actuator and rotor into the crankshaft.

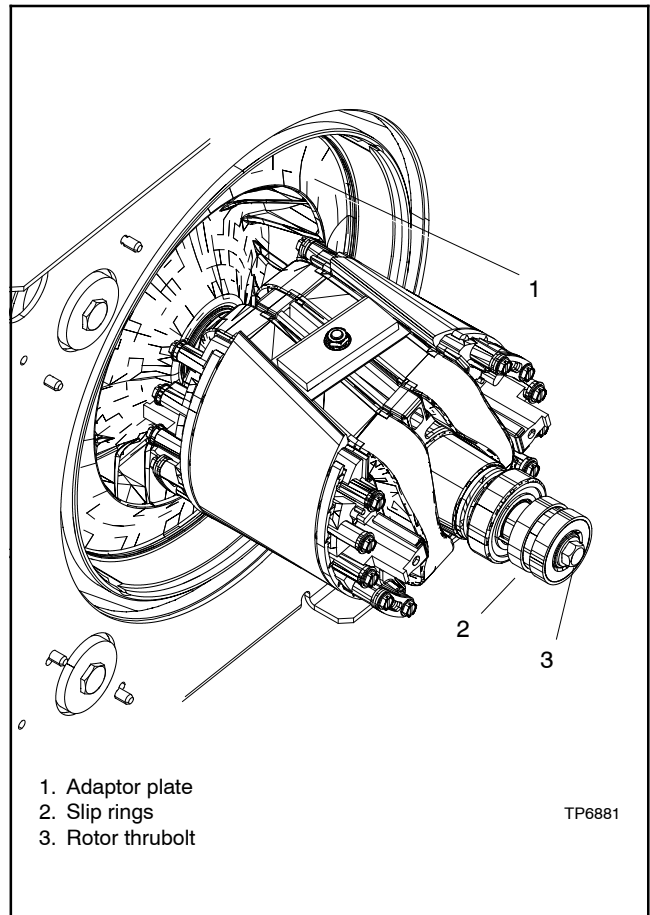
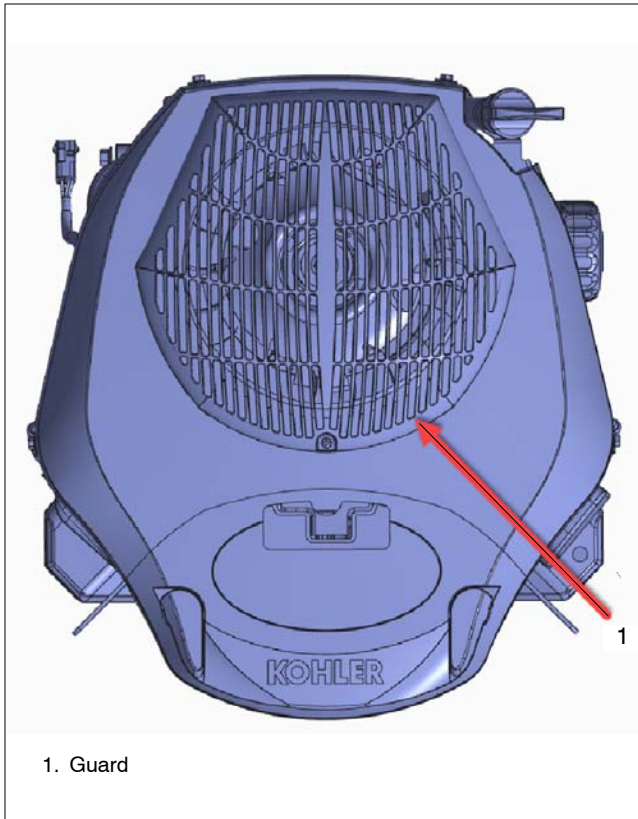

Figure 6-13 Rotor Assembly with Thrubolt

5. Tighten the rotor thrubolt to 33 Nm (24 ft. lb.). It may be necessary to keep the engine flywheel from turning while torquing the rotor thrubolt.
6. Install the stator and end bracket.
 - a. Align and install the stator assembly around the rotor.
 - b. Route the leads connected to the alternator end bracket through the opening in the base of the alternator frame.
 - c. Heat the inner diameter of end bracket with a 1500W heat gun for 5–6 minutes, or until center of the bracket reaches 93°C (200°F) to ease the installation of the bracket onto the rotor bearing. Measure the temperature with an IR thermometer or a thermocouple and multimeter, if available. See Figure 6-15.

Note: Handle the part with heat resistant gloves.



1. Guard

Figure 6-14 Guard

- d. While still hot, place the end bracket onto the stator assembly, lining up the alignment marks on the top of the stator and end bracket. See Figure 6-16.
- e. Thread the four overbolts with washers through the end bracket and into the adapter plate. See Figure 6-16.
- f. Tighten the four alternator assembly overbolts to 23 Nm (17 ft. lb.).

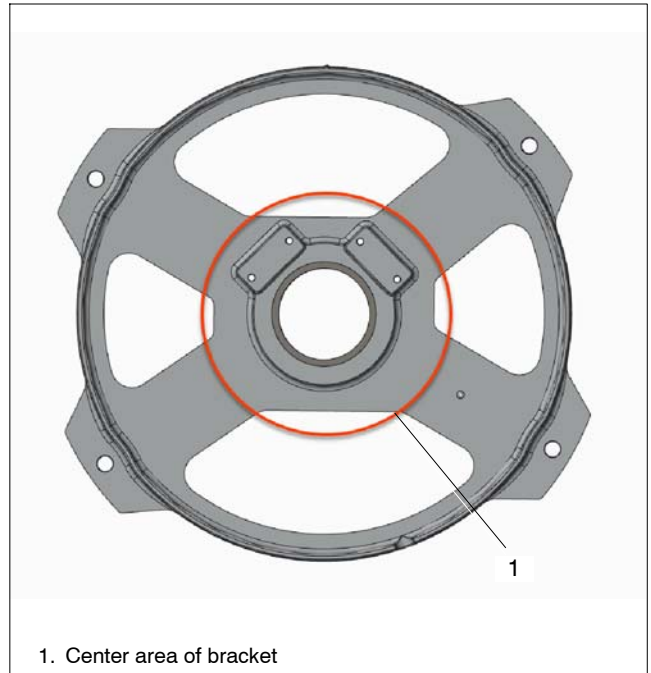

1. Center area of bracket

Figure 6-15 Center of End Bracket

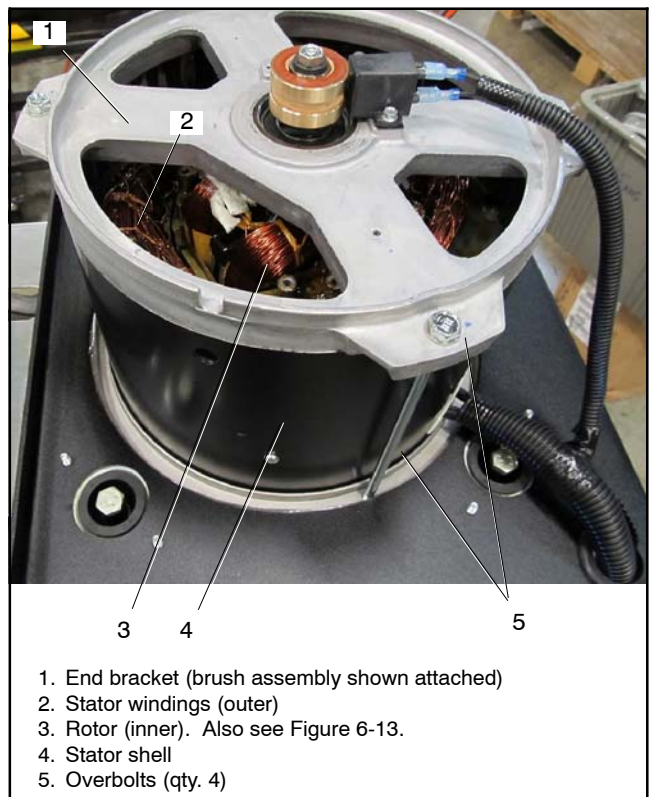

1. End bracket (brush assembly shown attached)
 2. Stator windings (outer)
 3. Rotor (inner). Also see Figure 6-13.
 4. Stator shell
 5. Overbolts (qty. 4)

Figure 6-16 End Bracket and Overbolt Assembly

7. Reinstall the end bracket components.
 - a. Inspect the brushes. If brushes show uneven wear or are worn to less than half their original length, replace them. See Section 5.7.
 - b. Install the brush holder with shim onto the end bracket. Verify that the brushes are not sticking in the holder.
 - c. Verify that the brushes are centered on the slip rings. If required, insert spacers between the mounting surface and brush holder to center the brushes on the slip rings. See Figure 6-18. See Section 5.7, Brushes, for more information.
 - d. Use the cable tie to secure the brush leads to the end bracket.

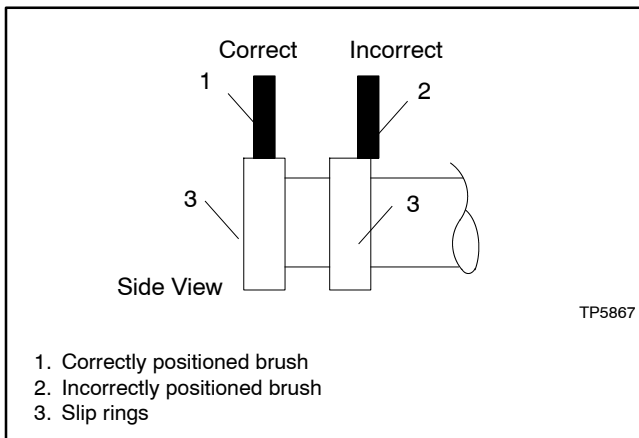

Figure 6-17 Brush Position

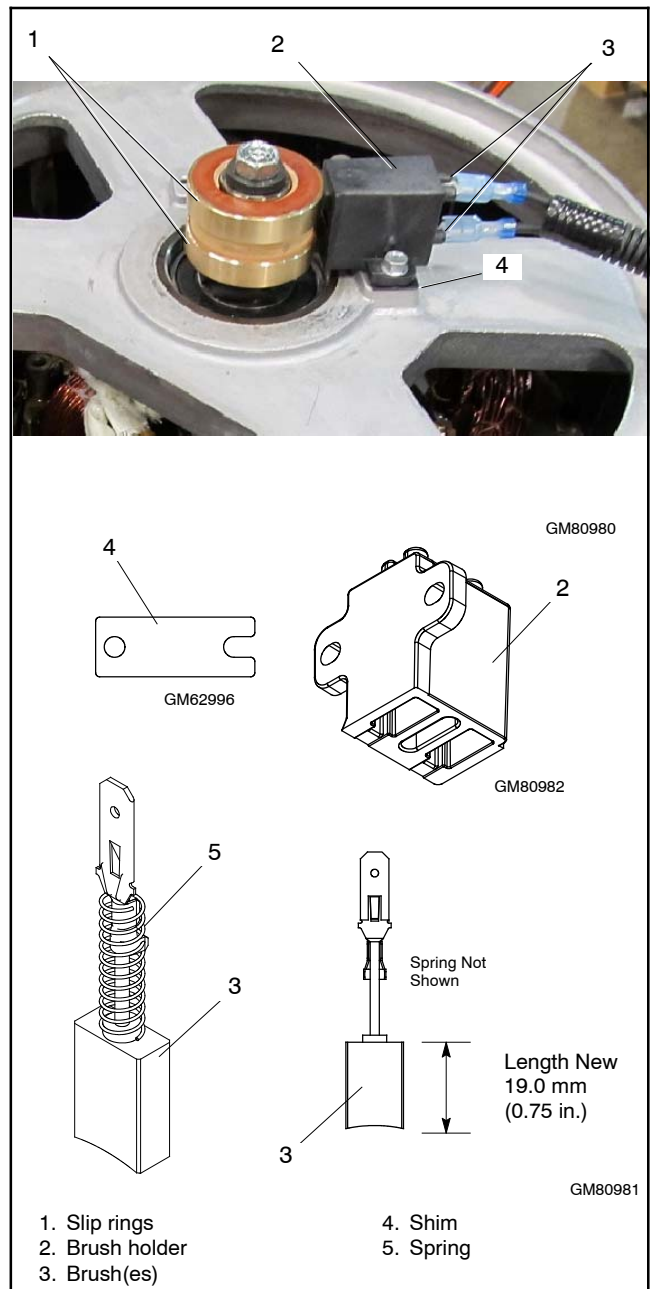

Figure 6-18 Brush Assembly

Repositioning the engine and alternator

8. Position a 273 mm (10-3/4 in.) block of wood to support the back corner of the mounting plate.

Note: If the corner of the mounting plate is not supported, the weight of the engine and alternator assembly can bend the sheet metal.

9. Connect a hoist to the lifting holes in the mounting plate. Lower the alternator and engine assembly and align the screw holes in the mount plate with the holes in the alternator box.

Note: Use a hoist or lifting device that is rated for the weight of the generator set. See Section 6.1.

10. Connect the mounting plate to the alternator box with six hex head screws.
11. Reposition the bulkhead and secure with five hex head screws.

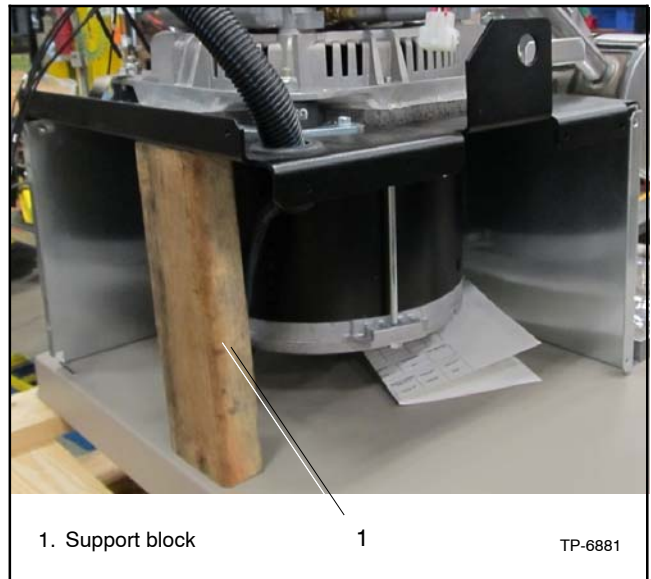

Figure 6-19 Support Block

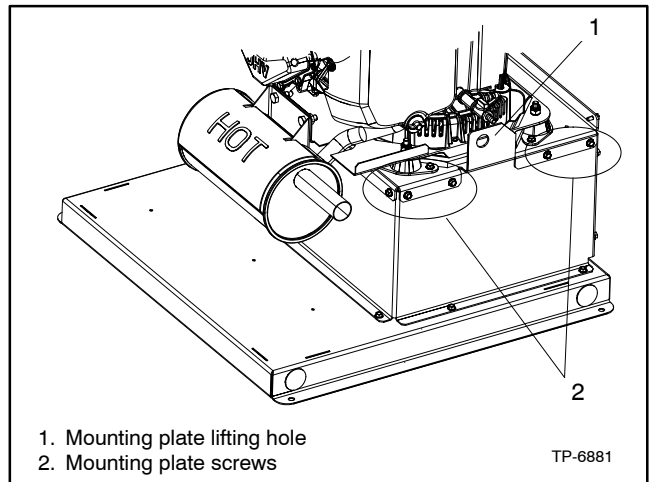

Figure 6-20 Mounting Plate

Connecting the electrical leads and harnesses

12. Connect the engine grounding strap.
13. Connect the wires and cables on the engine block ground.
14. Connect the P6 plug to the stepper motor, leads 1A, 1B, 2A, and 2B.
15. Connect the P7 plug to the oil temperature sensor, leads 69 and 69R.
16. Connect the P8 plug to the ignition coil and the low oil pressure switch, leads IGN and 13.
17. Reconnect the following alternator wiring inside the controller junction box. See the wiring diagrams in Section 7.
 - a. Leads 1 and 4 to the circuit breaker

Note: For **10RESV** and **12RESV** models, leads 1 and 4 must thread through the current transformer from opposite directions. Ensure that the leads cross through the current transformer when reconnecting. See Figure 6-21.

- b. Quick connection leads 55 and 55F on the 20 Amp auxiliary winding circuit breaker
 - c. LO and neutral Leads connected to the red insulator on the bottom of the junction box.
18. Connect the positive lead from the starter motor to the starter solenoid.
19. Connect the fuel line at the carburetor and secure with the fuel line pin.
20. Connect plug P2 to the controller. Position and secure the controller with the two controller screws.
21. Press the OFF button on the generator set controller.

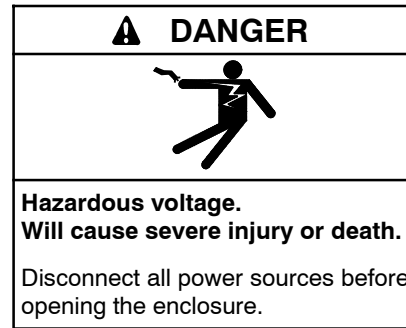

Connecting the battery and the battery charger.

Hazardous voltage will cause severe injury or death.

Reconnect the battery correctly, positive to positive and negative to negative, to avoid electrical shock and damage to the battery charger and battery(ies). Have a qualified electrician install the battery(ies).

22. Reconnect the generator set engine starting battery, negative (-) lead last.
23. Reconnect the carburetor heater (if equipped) to the 120VAC receptacle.



Figure 6-21 Current Transformer

Installing the enclosure

24. Reinstall the enclosure panels in reverse order of removal. See Figure 6-22 and Figure 6-23. Refer to the disassembly instructions, if necessary.
 - a. Install the front panel.
 - b. Position the rear panel and thread the load leads through the hole in the rear panel into the junction box. Connect the load leads to the circuit breaker.
 - c. Install the rear panel.
 - d. Install the left side panel (air-intake end).
 - e. Install the right side panel (exhaust end).

Important: Do not allow the roof to hang from the hinge in an overextended or unsupported position. Without support from the piston, the weight of the roof will damage the sheet metal. Get assistance to hold the roof open while completing the connection procedure.

25. To install the roof:
 - a. Position the enclosure roof and secure with the four hinge bolts.
 - b. Reattach the roof support piston.
 - c. Slide the retaining ring onto the support piston.

Note: Ensure that the retaining ring holds the support piston firmly in place. Crimp the retaining ring if necessary.

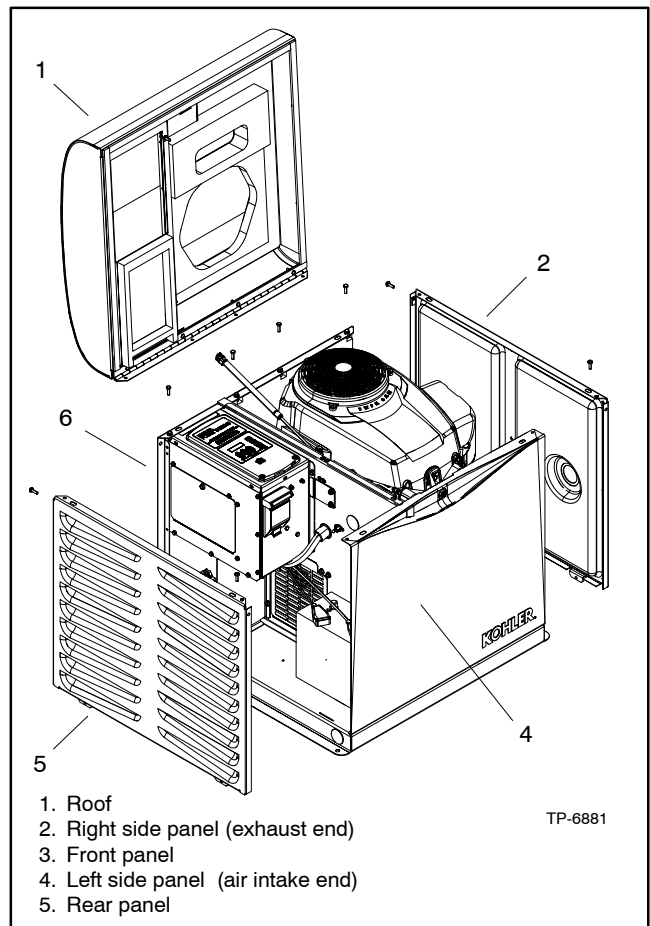

Figure 6-22 Enclosure

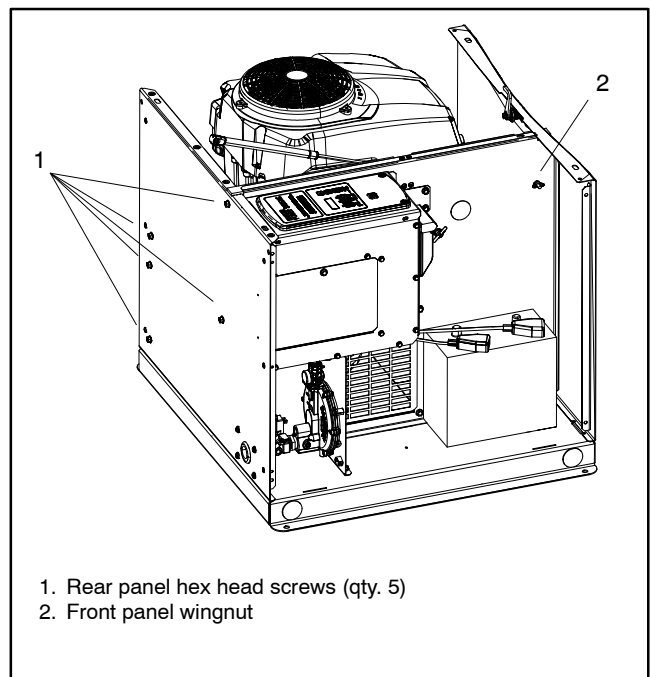
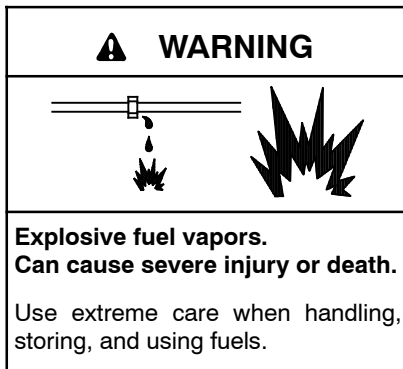

Figure 6-23 Front and Rear Panels

Final Steps



The fuel system. Explosive fuel vapors can cause severe injury or death. Vaporized fuels are highly explosive. Use extreme care when handling and storing fuels. Store fuels in a well-ventilated area away from spark-producing equipment and out of the reach of children. Never add fuel to the tank while the engine is running because spilled fuel may ignite on contact with hot parts or from sparks. Do not smoke or permit flames or sparks to occur near sources of spilled fuel or fuel vapors. Keep the fuel lines and connections tight and in good condition. Do not replace flexible fuel lines with rigid lines. Use flexible sections to avoid fuel line breakage caused by vibration. Do not operate the generator set in the presence of fuel leaks, fuel accumulation, or sparks. Repair fuel systems before resuming generator set operation.

Gas fuel leaks. Explosive fuel vapors can cause severe injury or death. Fuel leakage can cause an explosion. Check the LPG vapor or natural gas fuel system for leakage by using a soap and water solution with the fuel system test pressurized to 6–8 ounces per square inch (10–14 inches water column). Do not use a soap solution containing either ammonia or chlorine because both prevent bubble formation. A successful test depends on the ability of the solution to bubble.

LPG liquid withdrawal fuel leaks. Explosive fuel vapors can cause severe injury or death. Fuel leakage can cause an explosion. Check the LPG liquid withdrawal fuel system for leakage by using a soap and water solution with the fuel system test pressurized to at least 90 psi (621 kPa). Do not use a soap solution containing either ammonia or chlorine because both prevent bubble formation. A successful test depends on the ability of the solution to bubble.

26. Re-apply the 120VAC power supply to the generator set by closing the upstream circuit breaker.
27. Turn on the fuel supply. Press RUN to start the generator set and check for leaks with the engine running.
28. Press OFF to turn off the generator set. Then press AUTO if an automatic transfer switch or remote start/stop switch is used.
29. Lower and secure the roof.

Notes

Section 7 Drawings and Diagrams

Figure 7-2 lists the wiring diagram numbers and page numbers.

Note: The reduced minimum clearance from a structure contained in ADV-8774 (Figure 7-8) only applies to generators that are compliant with clause (2) of section 4.1.4 of NFPA 37. To verify that the generator is compliant, check the **Specification Number** located on the generator name plate. See Figure 7-1. If the name plate displays one of the following specification numbers, then the generator is compliant with clause (2) of section 4.1.4 of NFPA 37 and the reduced clearance in ADV-8774 (Figure 7-8) will apply.

- 8RESV: GM88347-GA7 or higher
- 8RESVL: GM88347-GA10 or higher
- 10RESV: GM88347-GA8 or higher
- 10RESVL: GM88347-GA11 or higher
- 12RESV: GM88347-GA9 or higher
- 12RESVL: GM88347-GA12 or higher

Note: If the generator set name plate does not display one of the specification numbers set forth above, refer to ADV-8539 (Figure 7-5) for the minimum clearance from a structure.

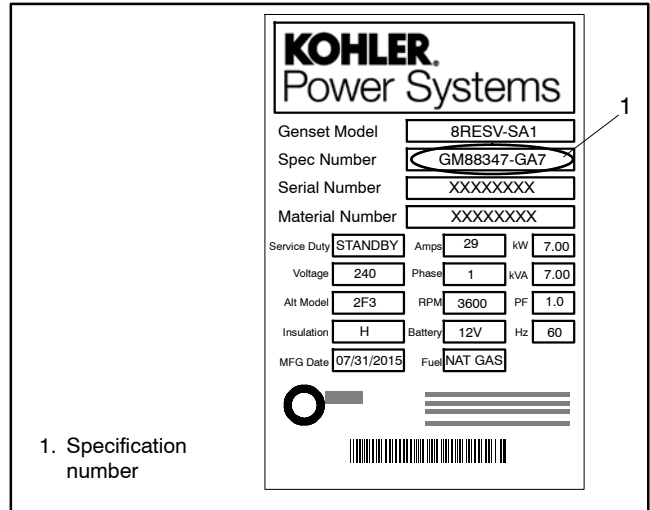

Figure 7-1 Name Plate

Dimension Drawing	Drawing Number	Page
Dimension drawing, specification number GM88347-GA1 to GM88347-GA6.	ADV-8539, Sheet 1	122
	ADV-8539, Sheet 2	123
	ADV-8539, Sheet 3	124
Dimension drawing, specification number GM88347-GA7 and higher.	ADV-8774, Sheet 1	125
	ADV-8774, Sheet 2	126
	ADV-8774, Sheet 3	127
Wiring Diagram Description	Drawing Number	Page
Schematic Diagram	ADV-8552	128
Point-to-Point Wiring Diagram	GM89012	129

Figure 7-2 Wiring Diagrams and Schematics

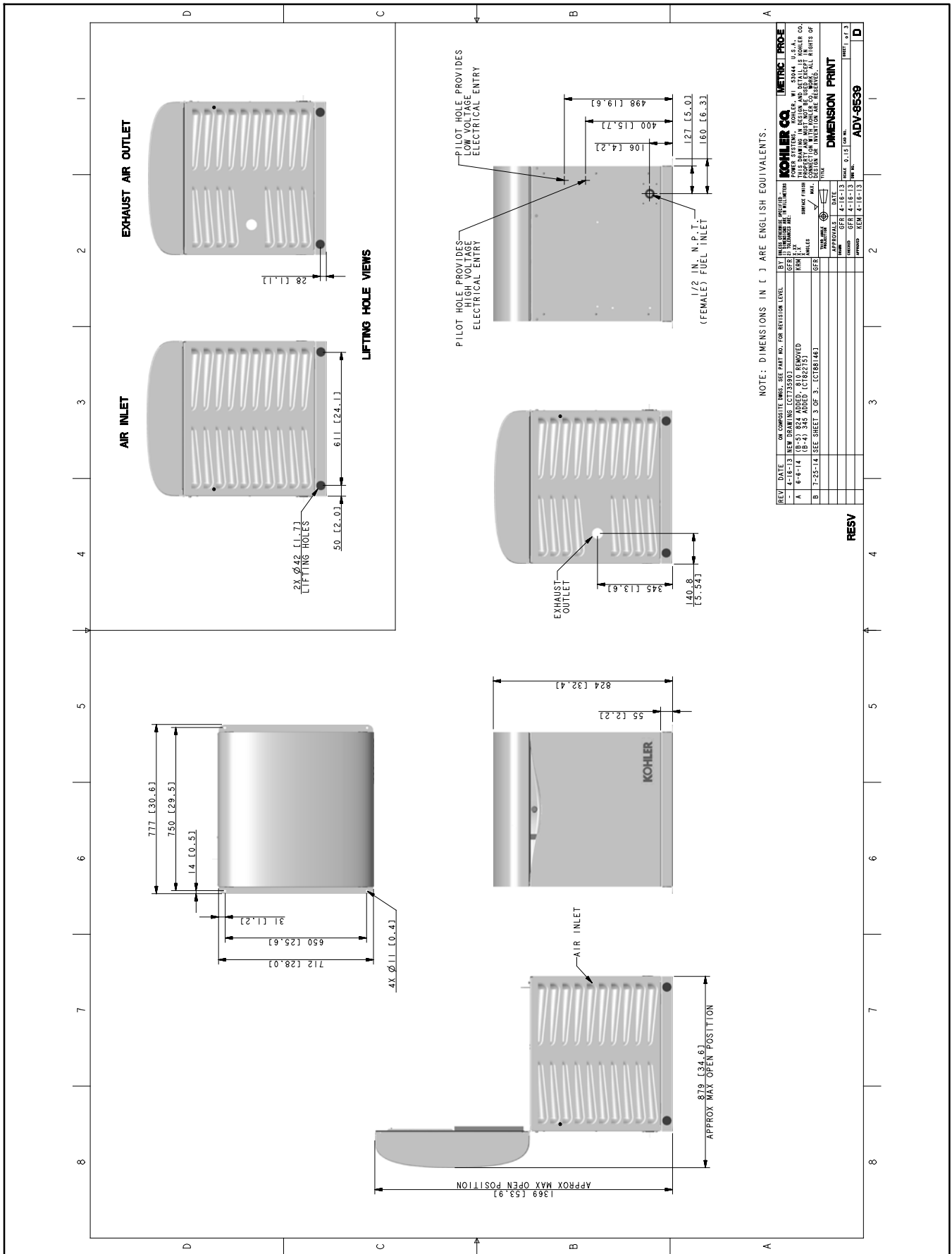

Figure 7-3 Dimension Drawing ADV-8539, Sheet 1 (for specification numbers GM88347-GA6 or lower)

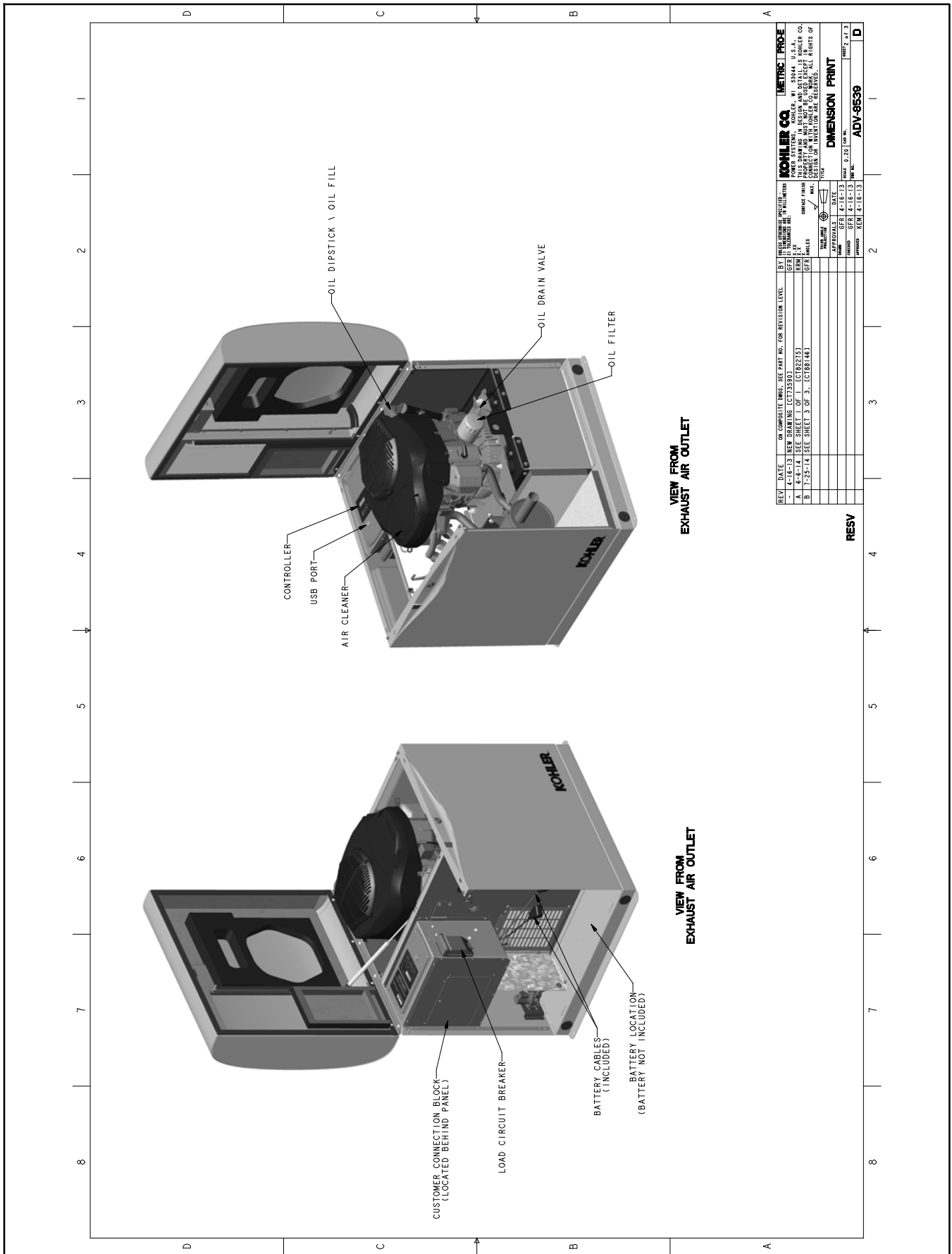

Figure 7-4 Dimension Drawing ADV-8539, Sheet 2 (for specification numbers GM88347-GA6 or lower)

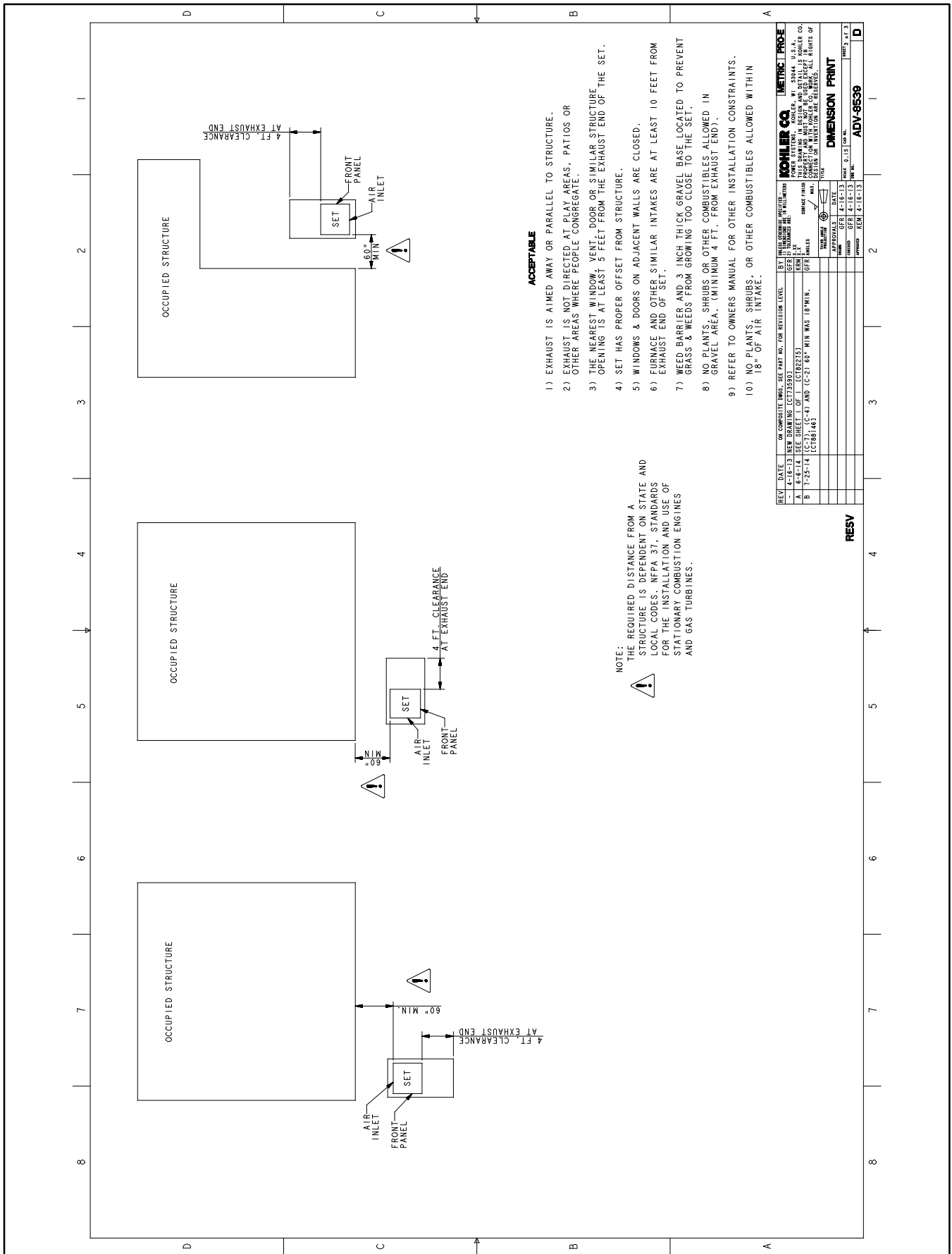

Figure 7-5 Dimension Drawing ADV-8539, Sheet 3 (for specification numbers GM88347-GA6 or lower)

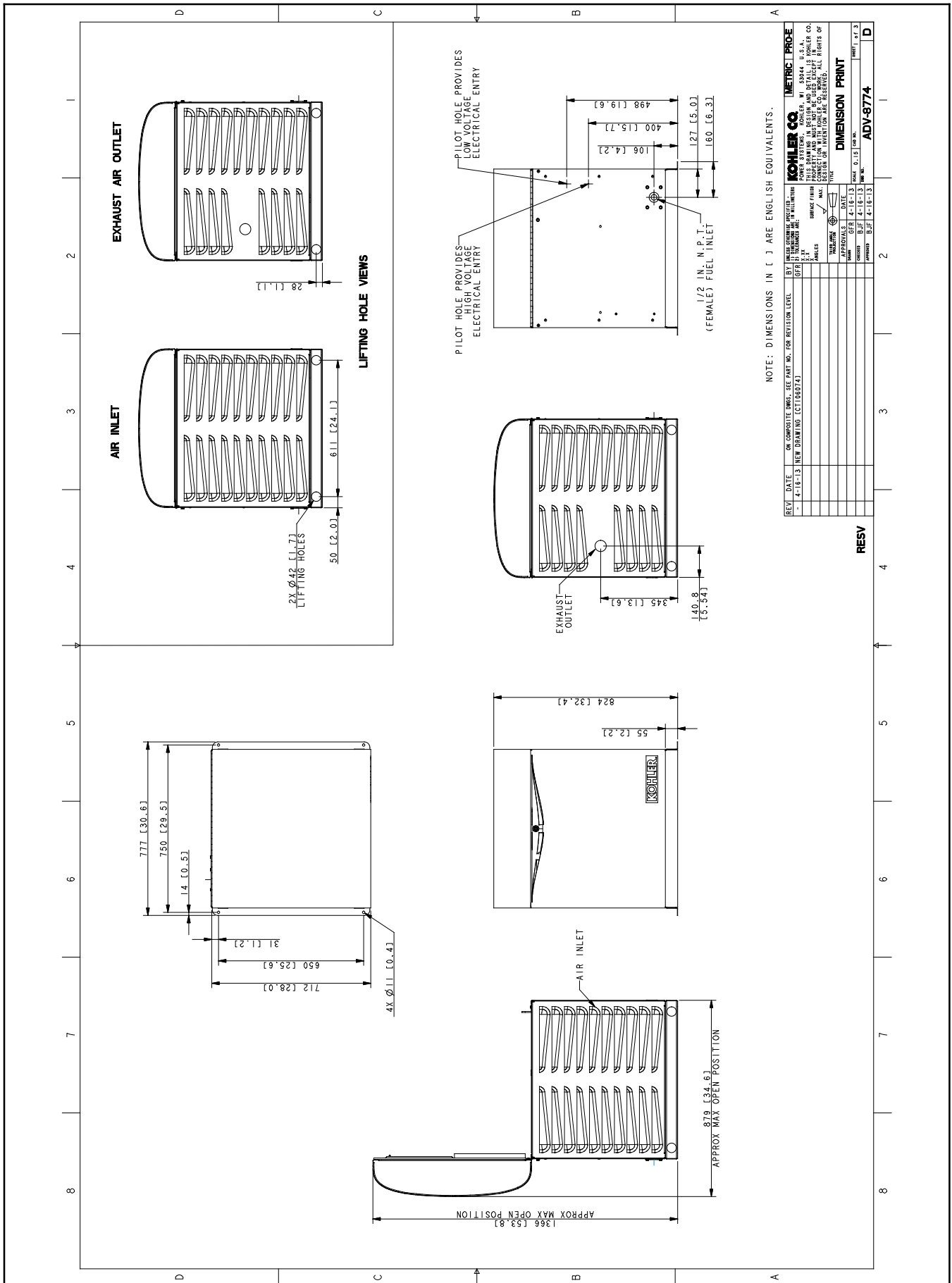

Figure 7-6 Dimension Drawing ADV-8774, Sheet 1 (for specification numbers GM88347-GA7 or higher)

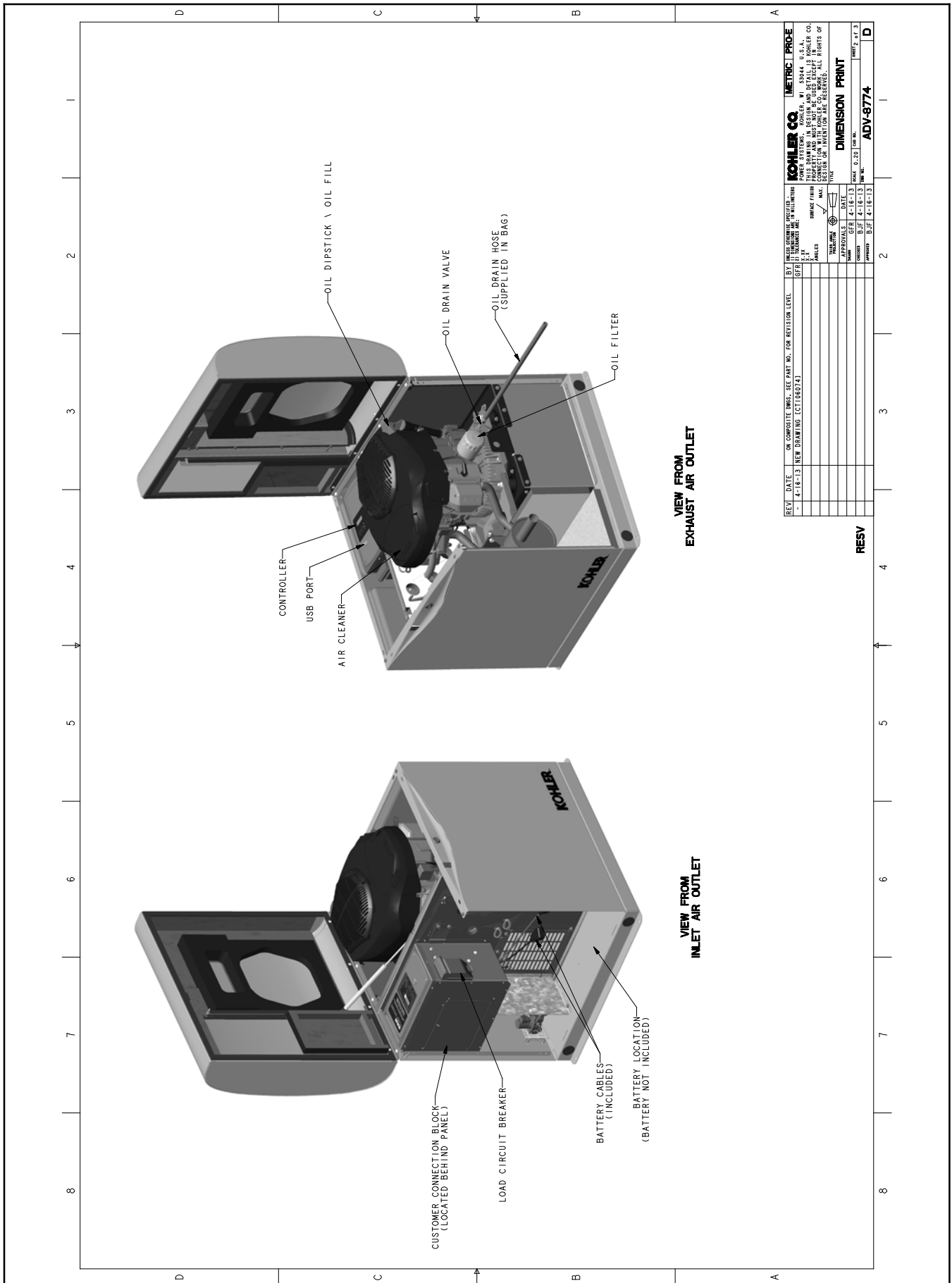

Figure 7-7 Dimension Drawing ADV-8774, Sheet 2 (for specification numbers GM88347-GA7 or higher)

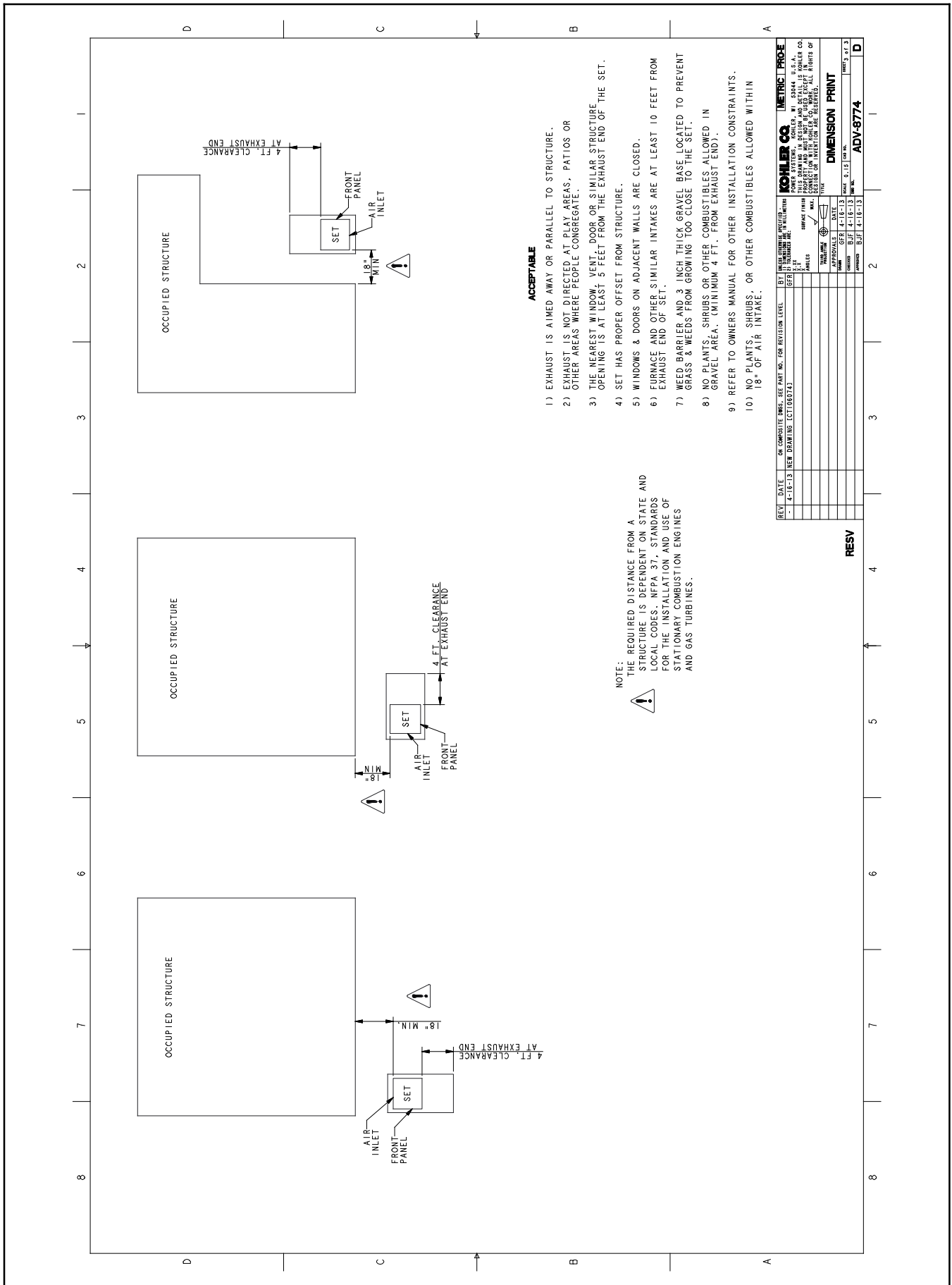

Figure 7-8 Dimension Drawing ADV-8774, Sheet 3 (for specification numbers GM88347-GA7 or higher)

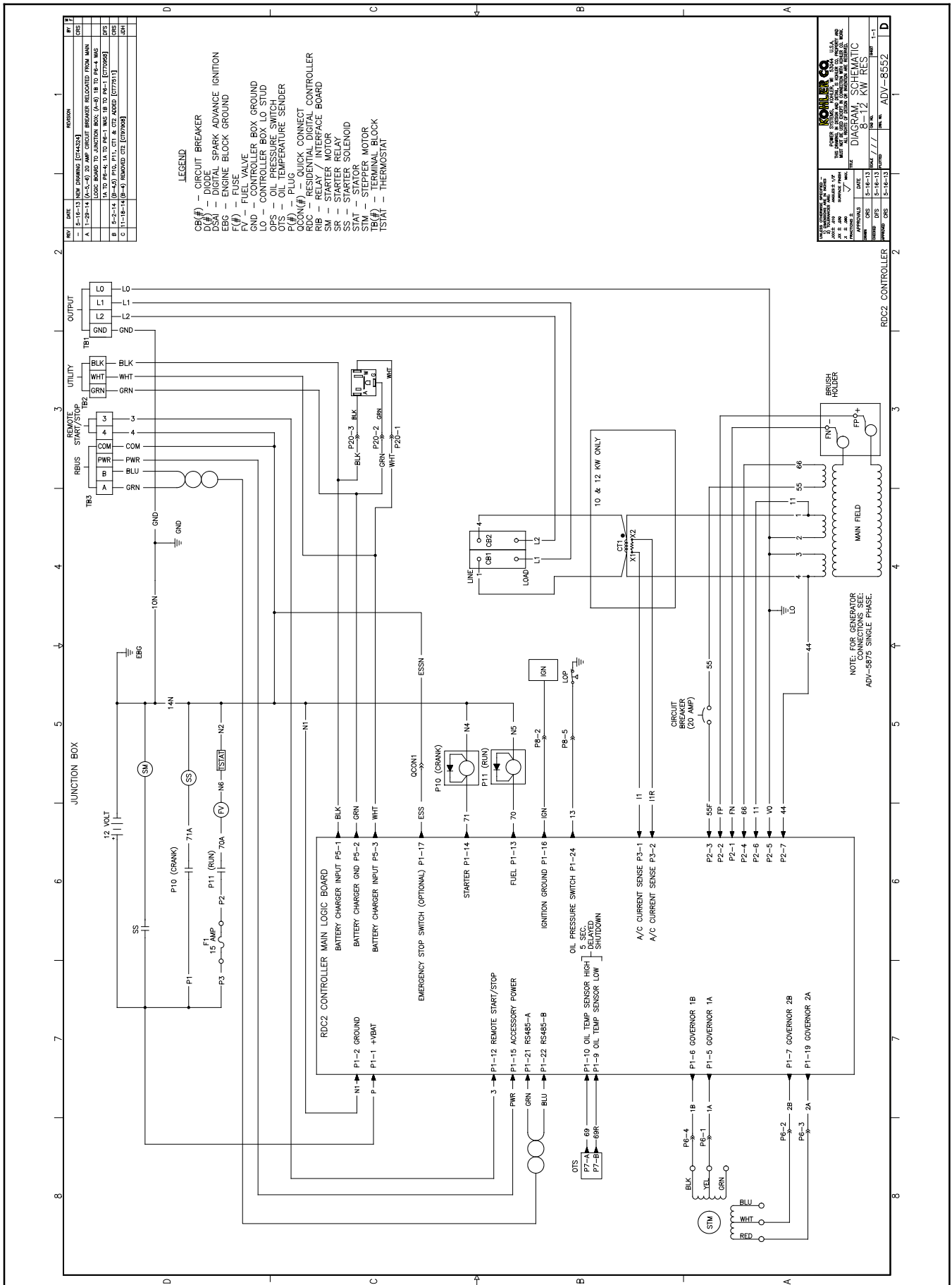

Figure 7-9 Schematic Diagram, ADV-8552

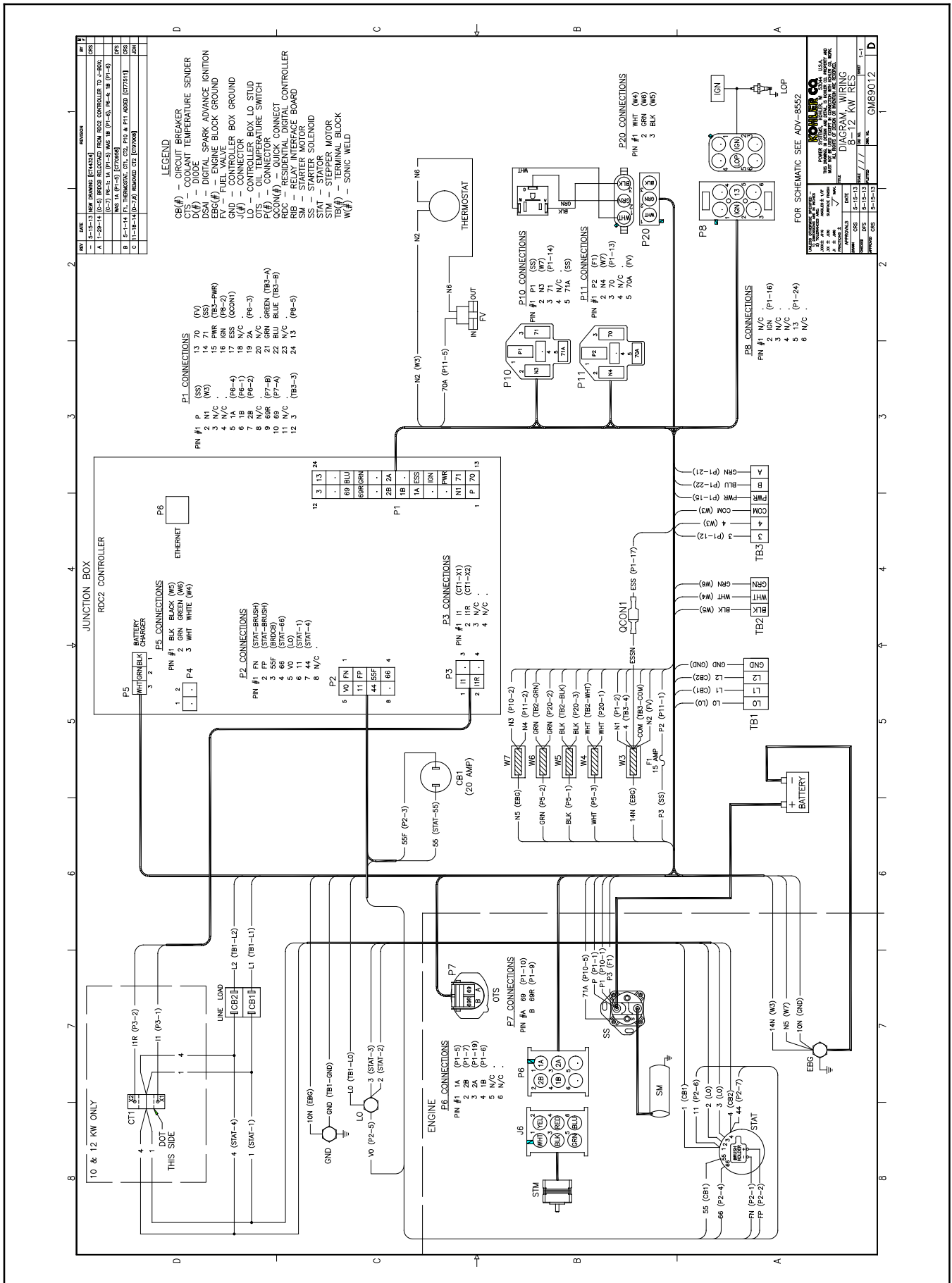

Figure 7-10 Point-to-Point Wiring Diagram, GM89012

Notes

Appendix A Abbreviations

The following list contains abbreviations that may appear in this publication.

A, amp	ampere	cfm	cubic feet per minute	est.	estimated
ABDC	after bottom dead center	CG	center of gravity	E-Stop	emergency stop
AC	alternating current	CID	cubic inch displacement	etc.	et cetera (and so forth)
A/D	analog to digital	CL	centerline	exh.	exhaust
ADC	advanced digital control; analog to digital converter	cm	centimeter	ext.	external
adj.	adjust, adjustment	CMOS	complementary metal oxide substrate (semiconductor)	F	Fahrenheit, female
ADV	advertising dimensional drawing	cogen.	cogeneration	fglass.	fiberglass
Ah	amp-hour	com	communications (port)	FHM	flat head machine (screw)
AHWT	anticipatory high water temperature	coml	commercial	fl. oz.	fluid ounce
AISI	American Iron and Steel Institute	Coml/Rec	Commercial/Recreational connection	flex.	flexible
ALOP	anticipatory low oil pressure	conn.	connection	freq.	frequency
alt.	alternator	cont.	continued	FS	full scale
Al	aluminum	CPVC	chlorinated polyvinyl chloride	ft.	foot, feet
ANSI	American National Standards Institute (formerly American Standards Association, ASA)	crit.	critical	ft. lb.	foot pounds (torque)
AO	anticipatory only	CRT	cathode ray tube	ft./min.	feet per minute
APDC	Air Pollution Control District	CSA	Canadian Standards Association	ftp	file transfer protocol
API	American Petroleum Institute	CT	current transformer	g	gram
approx.	approximate, approximately	Cu	copper	ga.	gauge (meters, wire size)
AQMD	Air Quality Management District	cUL	Canadian Underwriter's Laboratories	gal.	gallon
AR	as required, as requested	CUL	Canadian Underwriter's Laboratories	gen.	generator
AS	as supplied, as stated, as suggested	cu. in.	cubic inch	genset	generator set
ASE	American Society of Engineers	cw.	clockwise	GFI	ground fault interrupter
ASME	American Society of Mechanical Engineers	CWC	city water-cooled	GND, ⊕	ground
assy.	assembly	cyl.	cylinder	gov.	governor
ASTM	American Society for Testing Materials	D/A	digital to analog	gph	gallons per hour
ATDC	after top dead center	DAC	digital to analog converter	gpm	gallons per minute
ATS	automatic transfer switch	dB	decibel	gr.	grade, gross
auto.	automatic	dB(A)	decibel (A weighted)	GRD	equipment ground
aux.	auxiliary	DC	direct current	gr. wt.	gross weight
avg.	average	DCR	direct current resistance	H x W x D	height by width by depth
AVR	automatic voltage regulator	deg., °	degree	HC	hex cap
AWG	American Wire Gauge	dept.	department	HCHT	high cylinder head temperature
AWM	appliance wiring material	DFMEA	Design Failure Mode and Effects Analysis	HD	heavy duty
bat.	battery	dia.	diameter	HET	high exhaust temp., high engine temp.
BBDC	before bottom dead center	DI/EO	dual inlet/end outlet	hex	hexagon
BC	battery charger, battery charging	DIN	Deutsches Institut für Normung e. V. (also Deutsche Industrie Normenausschuss)	Hg	mercury (element)
BCA	battery charging alternator	DIP	dual inline package	HH	hex head
BCI	Battery Council International	DPDT	double-pole, double-throw	HHC	hex head cap
BDC	before dead center	DS	disconnect switch	HP	horsepower
BHP	brake horsepower	DVR	digital voltage regulator	hr.	hour
blk.	black (paint color), block (engine)	E, emer.	emergency (power source)	HS	heat shrink
blk. htr.	block heater	ECM	electronic control module, engine control module	hsg.	housing
BMEP	brake mean effective pressure	EDI	electronic data interchange	HVAC	heating, ventilation, and air conditioning
bps	bits per second	EFR	emergency frequency relay	HWT	high water temperature
br.	brass	e.g.	for example (<i>exempli gratia</i>)	Hz	hertz (cycles per second)
BTDC	before top dead center	EG	electronic governor	IC	integrated circuit
Btu	British thermal unit	EGSA	Electrical Generating Systems Association	ID	inside diameter, identification
Btu/min.	British thermal units per minute	EIA	Electronic Industries Association	IEC	International Electrotechnical Commission
C	Celsius, centigrade	EI/EO	end inlet/end outlet	IEEE	Institute of Electrical and Electronics Engineers
cal.	calorie	EMI	electromagnetic interference	IMS	improved motor starting
CAN	controller area network	emiss.	emission	in.	inch
CARB	California Air Resources Board	eng.	engine	in. H ₂ O	inches of water
CB	circuit breaker	EPA	Environmental Protection Agency	in. Hg	inches of mercury
cc	cubic centimeter	ER	emergency relay	in. lb.	inch pounds
CCA	cold cranking amps	ES	engineering special, engineered special	Inc.	incorporated
ccw.	counterclockwise	ESD	electrostatic discharge	ind.	industrial
CEC	Canadian Electrical Code			int.	internal
cert.	certificate, certification, certified			int./ext.	internal/external
cfh	cubic feet per hour			I/O	input/output
				IP	iron pipe
				ISO	International Organization for Standardization
				J	joule
				JIS	Japanese Industry Standard

k	kilo (1000)	MTBO	mean time between overhauls	rly.	relay
K	kelvin	mtg.	mounting	rms	root mean square
kA	kiloampere	MTU	Motoren- und Turbinen-Union	rnd.	round
KB	kilobyte (2 ¹⁰ bytes)	MW	megawatt	ROM	read only memory
KBus	Kohler communication protocol	mW	milliwatt	rot.	rotate, rotating
kg	kilogram	μF	microfarad	rpm	revolutions per minute
kg/cm ²	kilograms per square centimeter	N, norm.	normal (power source)	RS	right side
kgm	kilogram-meter	NA	not available, not applicable	RTU	remote terminal unit
kg/m ³	kilograms per cubic meter	nat. gas	natural gas	RTV	room temperature vulcanization
kHz	kilohertz	NBS	National Bureau of Standards	RW	read/write
kJ	kilojoule	NC	normally closed	SAE	Society of Automotive Engineers
km	kilometer	NEC	National Electrical Code	scfm	standard cubic feet per minute
kOhm, kΩ	kilo-ohm	NEMA	National Electrical Manufacturers Association	SCR	silicon controlled rectifier
kPa	kilopascal	NFPA	National Fire Protection Association	s, sec.	second
kph	kilometers per hour	Nm	newton meter	SI	<i>Système international d'unites</i> , International System of Units
kV	kilovolt	NO	normally open	SI/EO	side in/end out
kVA	kilovolt ampere	no., nos.	number, numbers	sil.	silencer
kVAR	kilovolt ampere reactive	NPS	National Pipe, Straight	SN	serial number
kW	kilowatt	NPSC	National Pipe, Straight-coupling	SNMP	simple network management protocol
kWh	kilowatt-hour	NPT	National Standard taper pipe thread per general use	SPDT	single-pole, double-throw
kWm	kilowatt mechanical	NPTF	National Pipe, Taper-Fine	SPST	single-pole, single-throw
kWth	kilowatt-thermal	NR	not required, normal relay	spec	specification
L	liter	ns	nanosecond	specs	specification(s)
LAN	local area network	OC	overcrank	sq.	square
L x W x H	length by width by height	OD	outside diameter	sq. cm	square centimeter
lb.	pound, pounds	OEM	original equipment manufacturer	sq. in.	square inch
lbm/ft ³	pounds mass per cubic feet	OF	overfrequency	SS	stainless steel
LCB	line circuit breaker	opt.	option, optional	std.	standard
LCD	liquid crystal display	OS	oversize, overspeed	stl.	steel
ld. shd.	load shed	OSHA	Occupational Safety and Health Administration	tach.	tachometer
LED	light emitting diode	OV	overvoltage	TD	time delay
Lph	liters per hour	oz.	ounce	TDC	top dead center
Lpm	liters per minute	p., pp.	page, pages	TDEC	time delay engine cooldown
LOP	low oil pressure	PC	personal computer	TDEN	time delay emergency to normal
LP	liquefied petroleum	PCB	printed circuit board	TDES	time delay engine start
LPG	liquefied petroleum gas	pF	picofarad	TDNE	time delay normal to emergency
LS	left side	PF	power factor	TDOE	time delay off to emergency
L _{wa}	sound power level, A weighted	ph., ∅	phase	TDON	time delay off to normal
LWL	low water level	PHC	Phillips® head Crimpite® (screw)	temp.	temperature
LWT	low water temperature	PHH	Phillips® hex head (screw)	term.	terminal
m	meter, milli (1/1000)	PHM	pan head machine (screw)	THD	total harmonic distortion
M	mega (10 ⁶ when used with SI units), male	PLC	programmable logic control	TIF	telephone influence factor
m ³	cubic meter	PMG	permanent magnet generator	TIR	total indicator reading
m ³ /hr.	cubic meters per hour	pot	potentiometer, potential	tol.	tolerance
m ³ /min.	cubic meters per minute	ppm	parts per million	turbo.	turbocharger
mA	milliampere	PROM	programmable read-only memory	typ.	typical (same in multiple locations)
man.	manual	psi	pounds per square inch	UF	underfrequency
max.	maximum	psig	pounds per square inch gauge	UHF	ultrahigh frequency
MB	megabyte (2 ²⁰ bytes)	pt.	pint	UL	Underwriter's Laboratories, Inc.
MCCB	molded-case circuit breaker	PTC	positive temperature coefficient	UNC	unified coarse thread (was NC)
MCM	one thousand circular mils	PTO	power takeoff	UNF	unified fine thread (was NF)
meggar	megohmmeter	PVC	polyvinyl chloride	univ.	universal
MHz	megahertz	qt.	quart, quarts	US	undersize, underspeed
mi.	mile	qty.	quantity	UV	ultraviolet, undervoltage
mil	one one-thousandth of an inch	R	replacement (emergency) power source	V	volt
min.	minimum, minute	rad.	radiator, radius	VAC	volts alternating current
misc.	miscellaneous	RAM	random access memory	VAR	voltampere reactive
MJ	megajoule	RDO	relay driver output	VDC	volts direct current
mJ	millijoule	ref.	reference	VFD	vacuum fluorescent display
mm	millimeter	rem.	remote	VGA	video graphics adapter
mOhm, mΩ	milliohm	Res/Coml	Residential/Commercial	VHF	very high frequency
MOhm, MΩ	megohm	RFI	radio frequency interference	W	watt
MOV	metal oxide varistor	RH	round head	WCR	withstand and closing rating
MPa	megapascal	RHM	round head machine (screw)	w/	with
mpg	miles per gallon			w/o	without
mph	miles per hour			wt.	weight
MS	military standard			xfmr	transformer
ms	millisecond				
m/sec.	meters per second				
MTBF	mean time between failure				

Appendix B Common Hardware Application Guidelines

Use the information below and on the following pages to identify proper fastening techniques when no specific reference for reassembly is made.

Bolt/Screw Length: When bolt/screw length is not given, use Figure 1 as a guide. As a general rule, a minimum length of one thread beyond the nut and a maximum length of 1/2 the bolt/screw diameter beyond the nut is the preferred method.

Washers and Nuts: Use split lock washers as a bolt locking device where specified. Use SAE flat washers with whiz nuts, spirallock nuts, or standard nuts and preloading (torque) of the bolt in all other applications.

See Appendix C, General Torque Specifications, and other torque specifications in the service literature.

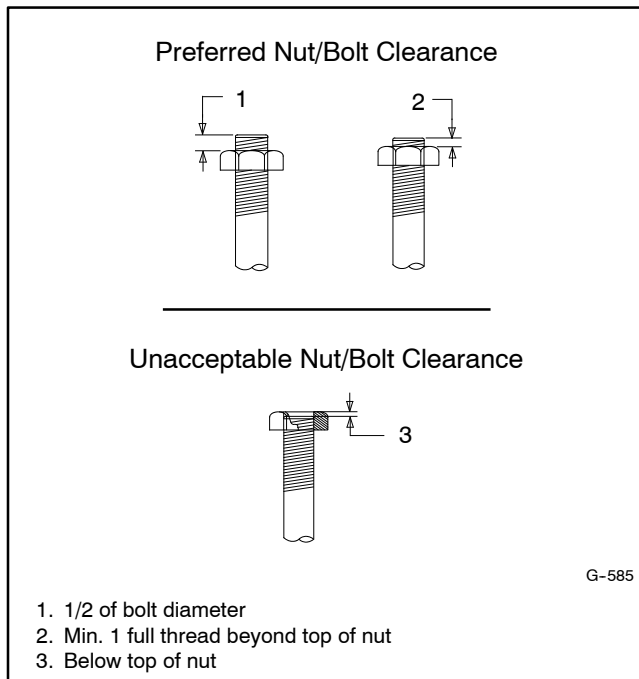

Figure 1 Acceptable Bolt Lengths

Steps for common hardware application:

1. Determine entry hole type: round or slotted.
2. Determine exit hole type: fixed female thread (weld nut), round, or slotted.

For round and slotted exit holes, determine if hardware is greater than 1/2 inch in diameter, or 1/2 inch in diameter or less. Hardware that is *greater than 1/2 inch* in diameter takes a standard nut and SAE washer. Hardware *1/2 inch or less* in diameter can take a properly torqued whiz nut or spirallock nut. See Figure 2.

3. Follow these SAE washer rules after determining exit hole type:
 - a. Always use a washer between hardware and a slot.
 - b. Always use a washer under a nut (see 2 above for exception).
 - c. Use a washer under a bolt when the female thread is fixed (weld nut).
4. Refer to Figure 2, which depicts the preceding hardware configuration possibilities.

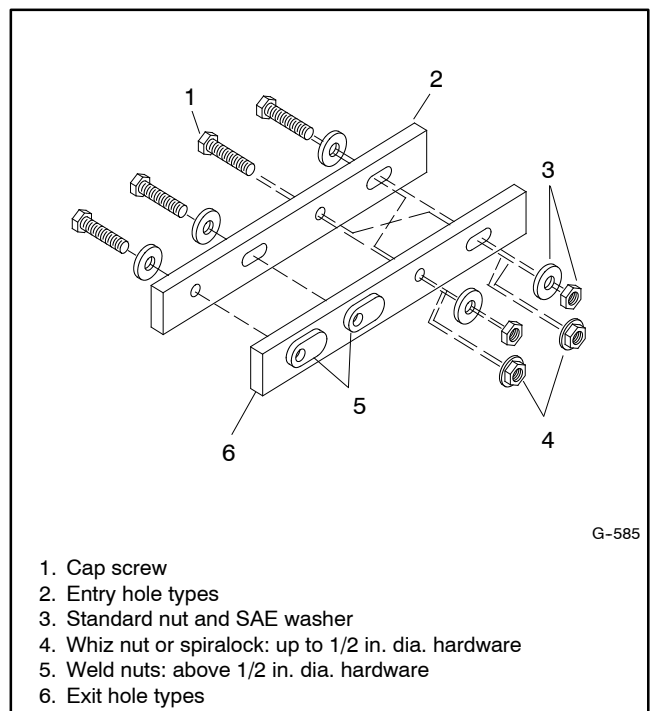

Figure 2 Acceptable Hardware Combinations

Appendix C General Torque Specifications

American Standard Fasteners Torque Specifications					
Size	Torque Measurement	Assembled into Cast Iron or Steel			Assembled into Aluminum Grade 2 or 5
		Grade 2	Grade 5	Grade 8	
8-32	Nm (in. lb.)	1.8 (16)	2.3 (20)	—	See Note 3
10-24	Nm (in. lb.)	2.9 (26)	3.6 (32)	—	
10-32	Nm (in. lb.)	2.9 (26)	3.6 (32)	—	
1/4-20	Nm (in. lb.)	6.8 (60)	10.8 (96)	14.9 (132)	
1/4-28	Nm (in. lb.)	8.1 (72)	12.2 (108)	16.3 (144)	
5/16-18	Nm (in. lb.)	13.6 (120)	21.7 (192)	29.8 (264)	
5/16-24	Nm (in. lb.)	14.9 (132)	23.1 (204)	32.5 (288)	
3/8-16	Nm (ft. lb.)	24.0 (18)	38.0 (28)	53.0 (39)	
3/8-24	Nm (ft. lb.)	27.0 (20)	42.0 (31)	60.0 (44)	
7/16-14	Nm (ft. lb.)	39.0 (29)	60.0 (44)	85.0 (63)	
7/16-20	Nm (ft. lb.)	43.0 (32)	68.0 (50)	95.0 (70)	
1/2-13	Nm (ft. lb.)	60.0 (44)	92.0 (68)	130.0 (96)	
1/2-20	Nm (ft. lb.)	66.0 (49)	103.0 (76)	146.0 (108)	
9/16-12	Nm (ft. lb.)	81.0 (60)	133.0 (98)	187.0 (138)	
9/16-18	Nm (ft. lb.)	91.0 (67)	148.0 (109)	209.0 (154)	
5/8-11	Nm (ft. lb.)	113.0 (83)	183.0 (135)	259.0 (191)	
5/8-18	Nm (ft. lb.)	128.0 (94)	208.0 (153)	293.0 (216)	
3/4-10	Nm (ft. lb.)	199.0 (147)	325.0 (240)	458.0 (338)	
3/4-16	Nm (ft. lb.)	222.0 (164)	363.0 (268)	513.0 (378)	
1-8	Nm (ft. lb.)	259.0 (191)	721.0 (532)	1109.0 (818)	
1-12	Nm (ft. lb.)	283.0 (209)	789.0 (582)	1214.0 (895)	















Metric Fasteners Torque Specifications, Measured in Nm (ft. lb.)				
Size (mm)	Assembled into Cast Iron or Steel			Assembled into Aluminum Grade 5.8 or 8.8
	Grade 5.8	Grade 8.8	Grade 10.9	
M6 x 1.00	6.2 (4.6)	9.5 (7)	13.6 (10)	See Note 3
M8 x 1.25	15.0 (11)	23.0 (17)	33.0 (24)	
M8 x 1.00	16.0 (11)	24.0 (18)	34.0 (25)	
M10 x 1.50	30.0 (22)	45.0 (34)	65.0 (48)	
M10 x 1.25	31.0 (23)	47.0 (35)	68.0 (50)	
M12 x 1.75	53.0 (39)	80.0 (59)	115.0 (85)	
M12 x 1.50	56.0 (41)	85.0 (63)	122.0 (90)	
M14 x 2.00	83.0 (61)	126.0 (93)	180.0 (133)	
M14 x 1.50	87.0 (64)	133.0 (98)	190.0 (140)	
M16 x 2.00	127.0 (94)	194.0 (143)	278.0 (205)	
M16 x 1.50	132.0 (97)	201.0 (148)	287.0 (212)	
M18 x 2.50	179.0 (132)	273.0 (201)	390.0 (288)	
M18 x 1.50	189.0 (140)	289.0 (213)	413.0 (305)	











Notes:





1. The torque values above are general guidelines. Always use the torque values specified in the service manuals and/or assembly drawings when they differ from the above torque values.
2. The torque values above are based on new plated threads. Increase torque values by 15% if non-plated threads are used.
3. Hardware threaded into aluminum must have either two diameters of thread engagement or a 30% or more reduction in the torque to prevent stripped threads.

4. Torque values are calculated as equivalent stress loading on American hardware with an approximate preload of 90% of the yield strength and a friction coefficient of 0.125.

Appendix D Common Hardware Identification

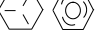
Screw/Bolts/Studs	
Head Styles	
Hex Head or Machine Head	
Hex Head or Machine Head with Washer	
Flat Head (FHM)	
Round Head (RHM)	
Pan Head	
Hex Socket Head Cap or Allen™ Head Cap	
Hex Socket Head or Allen™ Head Shoulder Bolt	
Sheet Metal Screw	
Stud	
Drive Styles	
Hex	
Hex and Slotted	
Phillips®	
Slotted	
Hex Socket	

Nuts	
Nut Styles	
Hex Head	
Lock or Elastic	
Square	
Cap or Acorn	
Wing	
Washers	
Washer Styles	
Plain	
Split Lock or Spring	
Spring or Wave	
External Tooth Lock	
Internal Tooth Lock	
Internal-External Tooth Lock	

Hardness Grades	
American Standard	
Grade 2	
Grade 5	
Grade 8	
Grade 8/9 (Hex Socket Head)	
Metric	
Number stamped on hardware; 5.8 shown	

Allen™ head screw is a trademark of Holo-Krome Co.

Phillips® screw is a registered trademark of Phillips Screw Company.

Sample Dimensions

American Standard (Screws, Bolts, Studs, and Nuts)

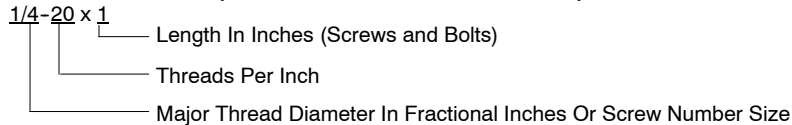

Metric (Screws, Bolts, Studs, and Nuts)

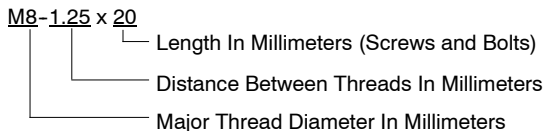

Plain Washers

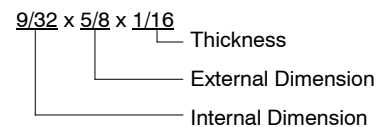

Lock Washers



Appendix E Common Hardware List

The Common Hardware List lists part numbers and dimensions for common hardware items.

American Standard

Part No. Dimensions Hex Head Bolts (Grade 5)

X-465-17	1/4-20 x .38
X-465-6	1/4-20 x .50
X-465-2	1/4-20 x .62
X-465-16	1/4-20 x .75
X-465-18	1/4-20 x .88
X-465-7	1/4-20 x 1.00
X-465-8	1/4-20 x 1.25
X-465-9	1/4-20 x 1.50
X-465-10	1/4-20 x 1.75
X-465-11	1/4-20 x 2.00
X-465-12	1/4-20 x 2.25
X-465-14	1/4-20 x 2.75
X-465-21	1/4-20 x 5.00
X-465-25	1/4-28 x .38
X-465-20	1/4-28 x 1.00
X-125-33	5/16-18 x .50
X-125-23	5/16-18 x .62
X-125-3	5/16-18 x .75
X-125-31	5/16-18 x .88
X-125-5	5/16-18 x 1.00
X-125-24	5/16-18 x 1.25
X-125-34	5/16-18 x 1.50
X-125-25	5/16-18 x 1.75
X-125-26	5/16-18 x 2.00
230578	5/16-18 x 2.25
X-125-29	5/16-18 x 2.50
X-125-27	5/16-18 x 2.75
X-125-28	5/16-18 x 3.00
X-125-22	5/16-18 x 4.50
X-125-32	5/16-18 x 5.00
X-125-35	5/16-18 x 5.50
X-125-36	5/16-18 x 6.00
X-125-40	5/16-18 x 6.50
X-125-43	5/16-24 x 1.75
X-125-44	5/16-24 x 2.50
X-125-30	5/16-24 x .75
X-125-39	5/16-24 x 2.00
X-125-38	5/16-24 x 2.75
X-6238-2	3/8-16 x .62
X-6238-10	3/8-16 x .75
X-6238-3	3/8-16 x .88
X-6238-11	3/8-16 x 1.00
X-6238-4	3/8-16 x 1.25
X-6238-5	3/8-16 x 1.50
X-6238-1	3/8-16 x 1.75
X-6238-6	3/8-16 x 2.00
X-6238-17	3/8-16 x 2.25
X-6238-7	3/8-16 x 2.50
X-6238-8	3/8-16 x 2.75
X-6238-9	3/8-16 x 3.00
X-6238-19	3/8-16 x 3.25
X-6238-12	3/8-16 x 3.50
X-6238-20	3/8-16 x 3.75
X-6238-13	3/8-16 x 4.50
X-6238-18	3/8-16 x 5.50
X-6238-25	3/8-16 x 6.50

Part No. Dimensions Hex Head Bolts, cont.

X-6238-14	3/8-24 x .75
X-6238-16	3/8-24 x 1.25
X-6238-21	3/8-24 x 4.00
X-6238-22	3/8-24 x 4.50
X-6024-5	7/16-14 x .75
X-6024-2	7/16-14 x 1.00
X-6024-8	7/16-14 x 1.25
X-6024-3	7/16-14 x 1.50
X-6024-4	7/16-14 x 2.00
X-6024-11	7/16-14 x 2.75
X-6024-12	7/16-14 x 6.50
X-129-15	1/2-13 x .75
X-129-17	1/2-13 x 1.00
X-129-18	1/2-13 x 1.25
X-129-19	1/2-13 x 1.50
X-129-20	1/2-13 x 1.75
X-129-21	1/2-13 x 2.00
X-129-22	1/2-13 x 2.25
X-129-23	1/2-13 x 2.50
X-129-24	1/2-13 x 2.75
X-129-25	1/2-13 x 3.00
X-129-27	1/2-13 x 3.50
X-129-29	1/2-13 x 4.00
X-129-30	1/2-13 x 4.50
X-463-9	1/2-13 x 5.50
X-129-44	1/2-13 x 6.00
X-129-51	1/2-20 x .75
X-129-45	1/2-20 x 1.25
X-129-52	1/2-20 x 1.50
X-6021-3	5/8-11 x 1.00
X-6021-4	5/8-11 x 1.25
X-6021-2	5/8-11 x 1.50
X-6021-1	5/8-11 x 1.75
273049	5/8-11 x 2.00
X-6021-5	5/8-11 x 2.25
X-6021-6	5/8-11 x 2.50
X-6021-7	5/8-11 x 2.75
X-6021-12	5/8-11 x 3.75
X-6021-11	5/8-11 x 4.50
X-6021-10	5/8-11 x 6.00
X-6021-9	5/8-18 x 2.50
X-6239-1	3/4-10 x 1.00
X-6239-8	3/4-10 x 1.25
X-6239-2	3/4-10 x 1.50
X-6239-3	3/4-10 x 2.00
X-6239-4	3/4-10 x 2.50
X-6239-5	3/4-10 x 3.00
X-6239-6	3/4-10 x 3.50
X-792-1	1-8 x 2.25
X-792-5	1-8 x 3.00
X-792-8	1-8 x 5.00

Part No. Dimensions Type

Hex Nuts

X-6009-1	1-8	Standard
X-6210-3	6-32	Whiz
X-6210-4	8-32	Whiz
X-6210-5	10-24	Whiz
X-6210-1	10-32	Whiz
X-6210-2	1/4-20	Spiralock
X-6210-6	1/4-28	Spiralock
X-6210-7	5/16-18	Spiralock
X-6210-8	5/16-24	Spiralock
X-6210-9	3/8-16	Spiralock
X-6210-10	3/8-24	Spiralock
X-6210-11	7/16-14	Spiralock
X-6210-12	1/2-13	Spiralock
X-6210-15	7/16-20	Spiralock
X-6210-14	1/2-20	Spiralock
X-85-3	5/8-11	Standard
X-88-12	3/4-10	Standard
X-89-2	1/2-20	Standard

Washers

Part No.	ID	OD	Thick.	Bolt/ Screw
X-25-46	.125	.250	.022	#4
X-25-9	.156	.375	.049	#6
X-25-48	.188	.438	.049	#8
X-25-36	.219	.500	.049	#10
X-25-40	.281	.625	.065	1/4
X-25-85	.344	.687	.065	5/16
X-25-37	.406	.812	.065	3/8
X-25-34	.469	.922	.065	7/16
X-25-26	.531	1.062	.095	1/2
X-25-15	.656	1.312	.095	5/8
X-25-29	.812	1.469	.134	3/4
X-25-127	1.062	2.000	.134	1

Metric

Hex head bolts are hardness grade 8.8 unless noted.

Part No. Dimensions Hex Head Bolts (Partial Thread)

M931-05055-60	M5-0.80 x 55
M931-06040-60	M6-1.00 x 40
M931-06055-60	M6-1.00 x 55
M931-06060-60	M6-1.00 x 60
M931-06060-SS	M6-1.00 x 60
M931-06070-60	M6-1.00 x 70
M931-06070-SS	M6-1.00 x 70
M931-06075-60	M6-1.00 x 75
M931-06090-60	M6-1.00 x 90
M931-06145-60	M6-1.00 x 145
M931-06150-60	M6-1.00 x 150
M931-08035-60	M8-1.25 x 35
M931-08040-60	M8-1.25 x 40
M931-08045-60	M8-1.25 x 45
M931-08050-60	M8-1.25 x 50
M931-08055-60	M8-1.25 x 55
M931-08055-82	M8-1.25 x 55*
M931-08060-60	M8-1.25 x 60
M931-08070-60	M8-1.25 x 70
M931-08070-82	M8-1.25 x 70*
M931-08075-60	M8-1.25 x 75
M931-08080-60	M8-1.25 x 80
M931-08090-60	M8-1.25 x 90
M931-08095-60	M8-1.25 x 95
M931-08100-60	M8-1.25 x 100
M931-08110-60	M8-1.25 x 110
M931-08120-60	M8-1.25 x 120
M931-08130-60	M8-1.25 x 130
M931-08140-60	M8-1.25 x 140
M931-08150-60	M8-1.25 x 150
M931-08200-60	M8-1.25 x 200
M931-10040-82	M10-1.25 x 40*
M931-10040-60	M10-1.50 x 40
M931-10045-60	M10-1.50 x 45
M931-10050-60	M10-1.50 x 50
M931-10050-82	M10-1.25 x 50*
M931-10055-60	M10-1.50 x 55
M931-10060-60	M10-1.50 x 60
M931-10065-60	M10-1.50 x 65
M931-10070-60	M10-1.50 x 70
M931-10080-60	M10-1.50 x 80
M931-10080-82	M10-1.25 x 80*
M931-10090-60	M10-1.50 x 90
M931-10090-82	M10-1.50 x 90*
M931-10100-60	M10-1.50 x 100
M931-10110-60	M10-1.50 x 110
M931-10120-60	M10-1.50 x 120
M931-10130-60	M10-1.50 x 130
M931-10140-60	M10-1.50 x 140
M931-10180-60	M10-1.50 x 180
M931-10235-60	M10-1.50 x 235
M931-10260-60	M10-1.50 x 260
M960-10330-60	M10-1.25 x 330
M931-12045-60	M12-1.75 x 45
M960-12050-60	M12-1.25 x 50
M960-12050-82	M12-1.25 x 50*
M931-12050-60	M12-1.75 x 50
M931-12050-82	M12-1.75 x 50*
M931-12055-60	M12-1.75 x 55
M931-12060-60	M12-1.75 x 60
M931-12060-82	M12-1.75 x 60*
M931-12065-60	M12-1.75 x 65
M931-12075-60	M12-1.75 x 75
M931-12080-60	M12-1.75 x 80
M931-12090-60	M12-1.75 x 90
M931-12100-60	M12-1.75 x 100
M931-12110-60	M12-1.75 x 110

Part No. Dimensions Hex Head Bolts (Partial Thread), continued

M960-16090-60	M16-1.50 x 90
M931-16090-60	M16-2.00 x 90
M931-16100-60	M16-2.00 x 100
M931-16100-82	M16-2.00 x 100*
M931-16120-60	M16-2.00 x 120
M931-16150-60	M16-2.00 x 150
M931-20065-60	M20-2.50 x 65
M931-20090-60	M20-2.50 x 90
M931-20100-60	M20-2.50 x 100
M931-20120-60	M20-2.50 x 120
M931-20140-60	M20-2.50 x 140
M931-20160-60	M20-2.50 x 160
M931-22090-60	M22-2.50 x 90
M931-22120-60	M22-2.50 x 120
M931-22160-60	M22-2.50 x 160
M931-24090-60	M24-3.00 x 90
M931-24120-60	M24-3.00 x 120
M931-24160-60	M24-3.00 x 160
M931-24200-60	M24-3.00 x 200

Hex Head Bolts (Full Thread)

M933-04006-60	M4-0.70 x 6
M933-05030-60	M5-0.80 x 30
M933-05035-60	M5-0.80 x 35
M933-05050-60	M5-0.80 x 50
M933-06010-60	M6-1.00 x 10
M933-06012-60	M6-1.00 x 12
M933-06014-60	M6-1.00 x 14
M933-06016-60	M6-1.00 x 16
M933-06020-60	M6-1.00 x 20
M933-06025-60	M6-1.00 x 25
M933-06030-60	M6-1.00 x 30
M933-06040-60	M6-1.00 x 40
M933-06050-60	M6-1.00 x 50
M933-07025-60	M7-1.00 x 25
M933-08010-60	M8-1.25 x 10
M933-08012-60	M8-1.25 x 12
M933-08016-60	M8-1.25 x 16
M933-08020-60	M8-1.25 x 20
M933-08025-60	M8-1.25 x 25
M933-08030-60	M8-1.25 x 30
M933-08030-82	M8-1.25 x 30*
M933-10012-60	M10-1.50 x 12
M961-10020-60	M10-1.25 x 20
M933-10020-60	M10-1.50 x 20
M933-10025-60	M10-1.50 x 25
M961-10025-60	M10-1.25 x 25
M933-10025-82	M10-1.50 x 25*
M961-10030-60	M10-1.25 x 30
M933-10030-60	M10-1.50 x 30
M933-10030-82	M10-1.50 x 30*
M961-10035-60	M10-1.25 x 35
M933-10035-60	M10-1.50 x 35
M933-10035-82	M10-1.50 x 35*
M961-10040-60	M10-1.25 x 40

Part No. Dimensions Hex Head Bolts (Full Thread), continued

M933-12016-60	M12-1.75 x 16
M933-12020-60	M12-1.75 x 20
M961-12020-60F	M12-1.50 x 20
M933-12025-60	M12-1.75 x 25
M933-12025-82	M12-1.75 x 25*
M961-12030-60	M12-1.25 x 30
M933-12030-82	M12-1.75 x 30*
M961-12030-82F	M12-1.50 x 30*
M933-12030-60	M12-1.75 x 30
M933-12035-60	M12-1.75 x 35
M961-12040-82	M12-1.25 x 40*
M933-12040-60	M12-1.75 x 40
M933-12040-82	M12-1.75 x 40*
M961-14025-60	M14-1.50 x 25
M933-14025-60	M14-2.00 x 25
M961-14050-82	M14-1.50 x 50*
M961-16025-60	M16-1.50 x 25
M933-16025-60	M16-2.00 x 25
M961-16030-82	M16-1.50 x 30*
M933-16030-82	M16-2.00 x 30*
M933-16035-60	M16-2.00 x 35
M961-16040-60	M16-1.50 x 40
M933-16040-60	M16-2.00 x 40
M961-16045-82	M16-1.50 x 45*
M933-16045-82	M16-2.00 x 45*
M933-16050-60	M16-2.00 x 50
M933-16050-82	M16-2.00 x 50*
M933-16060-60	M16-2.00 x 60
M933-16070-60	M16-2.00 x 70
M933-18035-60	M18-2.50 x 35
M933-18050-60	M18-2.50 x 50
M933-18060-60	M18-2.50 x 60
M933-20050-60	M20-2.50 x 50
M933-20055-60	M20-2.50 x 55
M933-24060-60	M24-3.00 x 60
M933-24065-60	M24-3.00 x 65
M933-24070-60	M24-3.00 x 70

Pan Head Machine Screws

M7985A-03010-20	M3-0.50 x 10
M7985A-03012-20	M3-0.50 x 12
M7985A-04010-20	M4-0.70 x 10
M7985A-04016-20	M4-0.70 x 16
M7985A-04020-20	M4-0.70 x 20
M7985A-04050-20	M4-0.70 x 50
M7985A-04100-20	M4-0.70 x 100
M7985A-05010-20	M5-0.80 x 10
M7985A-05012-20	M5-0.80 x 12
M7985A-05016-20	M5-0.80 x 16
M7985A-05020-20	M5-0.80 x 20
M7985A-05025-20	M5-0.80 x 25
M7985A-05030-20	M5-0.80 x 30
M7985A-05080-20	M5-0.80 x 80
M7985A-05100-20	M5-0.80 x 100
M7985A-06100-20	M6-1.00 x 100

Flat Head Machine Screws

M965A-04012-SS	M4-0.70 x 12
M965A-05012-SS	M5-0.80 x 12
M965A-05016-20	M5-0.80 x 16
M965A-06012-20	M6-1.00 x 12

* This metric hex bolt's hardness is grade 10.9.

Metric, continued

Part No.	Dimensions	Type
Hex Nuts		
M934-03-50	M3-0.50	Standard
M934-04-50	M4-0.70	Standard
M934-04-B	M4-0.70	Brass
M934-05-50	M5-0.80	Standard
M934-06-60	M6-1.00	Standard
M934-06-64	M6-1.00	Std. (green)
M6923-06-80	M6-1.00	Spirallock
M982-06-80	M6-1.00	Elastic Stop
M934-08-60	M8-1.25	Standard
M6923-08-80	M8-1.25	Spirallock
M982-08-80	M8-1.25	Elastic Stop
M934-10-60	M10-1.50	Standard
M934-10-60F	M10-1.25	Standard
M6923-10-80	M10-1.50	Spirallock
M6923-10-62	M10-1.50	Spirallock†
M982-10-80	M10-1.50	Elastic Stop
M934-12-60	M12-1.75	Standard
M934-12-60F	M12-1.25	Standard
M6923-12-80	M12-1.75	Spirallock
M982-12-80	M12-1.75	Elastic Stop
M982-14-60	M14-2.00	Elastic Stop
M6923-16-80	M16-2.00	Spirallock
M982-16-80	M16-2.00	Elastic Stop
M934-18-80	M18-2.5	Standard
M982-18-60	M18-2.50	Elastic Stop
M934-20-80	M20-2.50	Standard
M982-20-80	M20-2.50	Elastic Stop
M934-22-60	M22-2.50	Standard
M934-24-80	M24-3.00	Standard
M982-24-60	M24-3.00	Elastic Stop
M934-30-80	M30-3.50	Standard

Washers

Part No.	ID	OD	Thick.	Bolt/ Screw
M125A-03-80	3.2	7.0	0.5	M3
M125A-04-80	4.3	9.0	0.8	M4
M125A-05-80	5.3	10.0	1.0	M5
M125A-06-80	6.4	12.0	1.6	M6
M125A-08-80	8.4	16.0	1.6	M8
M125A-10-80	10.5	20.0	2.0	M10
M125A-12-80	13.0	24.0	2.5	M12
M125A-14-80	15.0	28.0	2.5	M14
M125A-16-80	17.0	30.0	3.0	M16
M125A-18-80	19.0	34.0	3.0	M18
M125A-20-80	21.0	37.0	3.0	M20
M125A-24-80	25.0	44.0	4.0	M24

† This metric hex nut's hardness is grade 8.

TP-6881 8/24c

© 2014 - Discovery Energy LLC - All rights reserved.

KOHLER®

Discovery Energy, LLC
200 Twin Oaks Road, Kohler, WI 53044 USA
For the nearest sales and service outlet in
the US and Canada, phone 1-800-544-2444
KOHLEREnergy.com